



Fisher Engineering

50 Gordon Drive, Rockland, Maine 04841-2139 • www.fisherplows.com

**9700, 9800, 9900
29600, 29700
29800, 49900**

June 1, 2008
Lit. No. 96446, Rev. 05

CONTROL KITS

XLS™, XtremeV™ & EZ-V® Fish-Stik® Hand-Held and XLS, XtremeV & EZ-V Joystick

Parts List

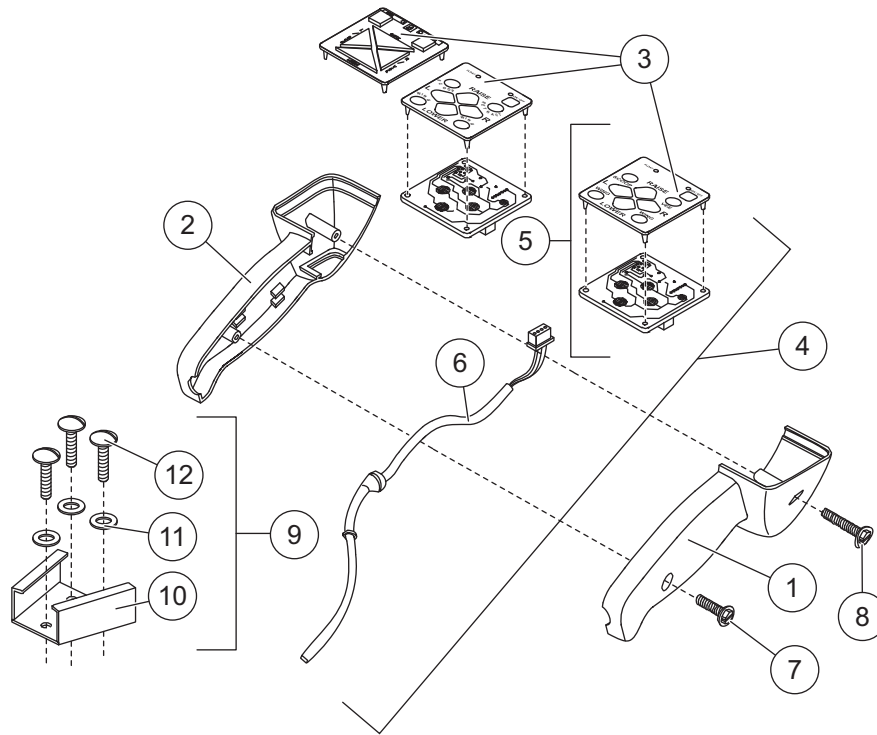

**29800 (XLS), 29600 (XtremeV),
9800 (EZ-V – 9-Button) and 9700 (EZ-V – 6-Button)**

Item	Part	Qty	Description	Item	Part	Qty	Description
1	96456	1	Control Body – Right	6	96464	1	Harness – 9-Button (4-Pin)
2	96457	1	Control Body – Left		96454	1	Harness – 9-Button (10-Pin)
3	96450	1	Keypad – XLS, XtremeV & EZ-V (9-Button)	7	93173	1	8-18 x 3/4 Tapping Screw
	66794	1	Keypad – EZ-V (6-Button)	8	93174	1	8-18 x 1-1/4 Tapping Screw
4	69281	1	PC Board/Harness (9-Button)	9	64312	1	Parts Bag – Control Bracket
5	96438	1	PC Board & Keypad – 9-Button (4-Pin) XtremeV	ns	69190	–	Fuse Kit (Package of 5) – EZ-V Only
	49471	1	PC Board & Keypad – 9-Button (4-Pin) XLS	64312 Parts Bag – Control Bracket			
	96449	1	PC Board & Keypad – 9-Button (10-Pin) EZ-V	10		1	Control Bracket
				11		3	6 Spring Lock Washer
				12		3	6-32 x 1 Tapping Screw

ns = not shown

9700, 9800, 9900, 29600, 29700, 29800, 49900

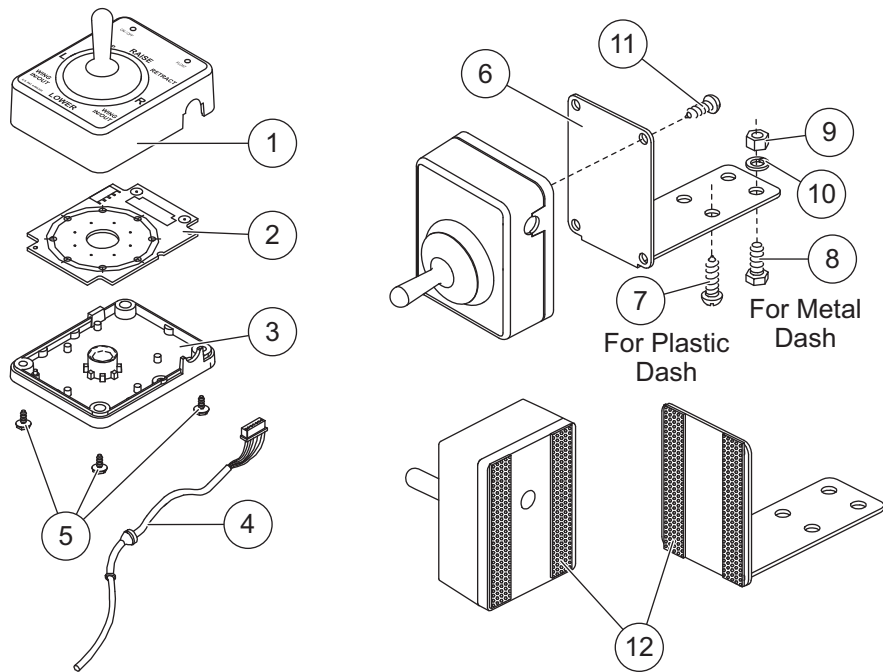

49900 (XLS™), 29700 (XtremeV™) and 9900 (EZ-V®)							
Item	Part	Qty	Description	Item	Part	Qty	Description
1	96358	1	Cover Assembly w/Actuator Spring & Label	4	96352	1	Harness (4-Pin)
2	96353	1	PC Board (4-Pin)		96365	1	Harness (10-Pin)
	96367	1	PC Board (10-Pin)	5	96364	3	4 x 3/8 Tapping Screw
3	96366	1	Bottom Housing	ns	96363	1	Dash Bracket Parts Bag
				ns	69190	-	Fuse Kit (Package of 5) – EZ-V Only
96363 Dash Bracket Parts Bag							
6		1	Control Bracket	10		2	1/4 Spring Lock Washer
7		4	12-14 x 3/4 Tapping Screw	11		2	8-18 x 5/8 Tapping Screw
8		2	1/4-20 x 3/4 Hex Cap Screw G5	12	20254K	1	Dual Lock Mounting Kit
9		2	1/4-20 Hex Nut G5				
G = Grade				ns = not shown			

Copyright © 2008 Douglas Dynamics, L.L.C. All rights reserved. This material may not be reproduced or copied, in whole or in part, in any printed, mechanical, electronic, film or other distribution and storage media, without the written consent of Fisher Engineering. Authorization to photocopy items for internal or personal use by Fisher Engineering outlets or snowplow owner is granted.

Fisher Engineering reserves the right under its product improvement policy to change construction or design details and furnish equipment when so altered without reference to illustrations or specifications used. Fisher Engineering or the vehicle manufacturer may require or recommend optional equipment for snow removal. Do not exceed vehicle ratings with a snowplow. Fisher Engineering offers a limited warranty for all snowplows and accessories. See separately printed page for this important information. The following are registered (®) trademarks of Douglas Dynamics, L.L.C.: EZ-V®, FISHER®, Fish-Stik®, XLS™, XtremeV™.

Printed in U.S.A.