



**PICKUP TRUCK SNOWPLOW  
C-PLOW**

**Poly Moldboard w/Trip Edge**

**Models 8803, 8903**

**OPERATOR'S MANUAL**

DO NOT USE OR OPERATE THIS EQUIPMENT UNTIL THIS MANUAL  
HAS BEEN READ AND THOROUGHLY UNDERSTOOD

PART NUMBER 25014182

---

---

---



# TABLE OF CONTENTS

<b>25014182</b>	<b>6/20</b>	<b>Hiniker/25014182</b>
TO THE PURCHASER.....		2
SAFETY.....		3
OPERATING PROCEDURES .....		4
TROUBLE SHOOTING .....		10
MAINTENANCE .....		12
ASSEMBLY .....		14
SYSTEM CHECK-OUT AND JOYSTICK CONFIGURATION .....		25
HEADLAMP AIMING PROCEDURE .....		26
SPECIFICATIONS.....		27
ELECTRICAL CIRCUIT.....		28, 29
HYDRAULIC CIRCUIT .....		30, 31
WARRANTY .....		32

# TO THE PURCHASER

This product is designed and manufactured to give years of dependable service when properly maintained and used for the purpose for which it is intended. Never allow anyone to operate this equipment until they fully understand the complete contents of this manual. It is the responsibility of owners who do not operate this equipment to ensure the operator is properly instructed and understands the contents of this manual. It is also the owner's responsibility to ensure that anyone operating this equipment is mentally and physically capable of so doing.

Important information is contained in this manual to help ensure safe and efficient operation.

If you have any questions about this manual, or the equipment discussed herein, contact your Hiniker dealer.



**TAKE NOTE! THIS SAFETY ALERT SYMBOL FOUND THROUGHOUT THIS MANUAL IS USED TO CALL YOUR ATTENTION TO INSTRUCTIONS INVOLVING YOUR PERSONAL SAFETY AND THE SAFETY OF OTHERS. FAILURE TO FOLLOW THESE INSTRUCTIONS CAN RESULT IN INJURY OR DEATH.**



**THIS SYMBOL MEANS:**

- ATTENTION!
- BECOME ALERT!
- YOUR SAFETY IS INVOLVED!



**SAFETY SIGNAL WORDS:**

**DANGER:** Indicates an imminently hazardous situation that, if not avoided, will result in death or serious injury.

**WARNING:** Indicates a potentially hazardous situation that, if not avoided, could result in death or serious injury.

**CAUTION:** Indicates a potentially hazardous situation that, if not avoided, may result in minor or moderate injury, or damage to components.

**NOTE:** Addresses safety practices not related to personal safety.

All references to LEFT or RIGHT are defined as viewing the plow from the cab of the truck.

Instructions for raising and lowering the plow refer to the joystick controller as received from the factory. The raise and lower functions may be reversed to suit the preference of the operator by following the instructions on page 25 for switching the controller joystick and face plate.

This Operator's manual is shipped with this equipment. Contact your Hiniker dealer for additional copies.

Always obtain original Hiniker service parts. Substitute parts could adversely affect equipment performance and warranty.

Check that your dealer has forwarded to Hiniker Company the delivery report form along with the plow identification number because it helps to maintain maximum service and warranty benefits. This does not put you on any mailing list, and information thereon is not available to others.

Your plow's identification number decal is at location (1) in the following illustration.

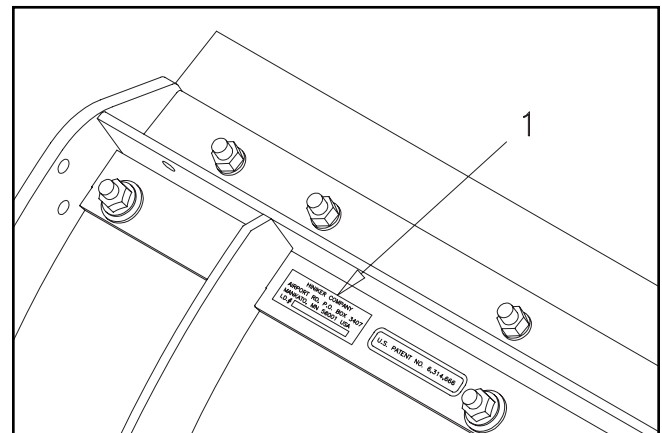

DWG NO. 5464

Record the following information for later reference when obtaining service parts:

Purchase Date \_\_\_\_\_

Purchaser's Name \_\_\_\_\_

Dealer's Name \_\_\_\_\_

Machine I.D. No. \_\_\_\_\_

# SAFETY

---



**This is a safety alert symbol. It alerts an operator to information concerning personal safety. Always observe and heed these symbols and instructions, otherwise death or serious injury can result.**

Operator safety is a principle concern in equipment design and distribution. However, many accidents occur because a few seconds of thought, and a more careful approach to handling, were ignored.

Accidents can be avoided by knowing and following the precautions cited in this manual.

## GENERAL SAFETY

1. Read this manual thoroughly. Make sure the operator understands it and knows how to operate this equipment safely. This equipment can kill or injure an untrained or careless operator and bystanders. If you sell this equipment, ensure the new owner acknowledges receipt of this manual.
2. This plow is intended for plowing snow only. Plowing gravel, rocks, etc., or using the plow for any purpose other than plowing snow could result in harm to the operator or bystanders or cause damage to the plow or vehicle.
3. Do not service or otherwise handle a plow in the raised position unless it is securely blocked against unexpected falling.

Likewise, bolt or pin ribs on the back of the moldboard to prevent unexpected rollover of the plow due to accidental loss of hydraulic pressure or cylinder removal.

4. Do not attempt to handle or service this equipment, or direct others to do the same, unless you know how to do it safely and have the proper tools for the job.
5. Keep hands, feet, hair, and clothing away from moving parts.
6. Do not alter the equipment to the extent of compromising safety or performance.

## BEFORE OPERATION

1. Discipline yourself to visually check for worn, damaged or cracked parts before starting use. Replace these with genuine Hiniker parts.
2. Escaping hydraulic oil under pressure can penetrate the skin, causing serious injury.

Do not use your hand to check for leaks. Use a piece of paper or cardboard to find suspected leaks.

Tighten all connections before pressurizing hydraulic lines.

If fluid is injected into the skin, get medical attention immediately to prevent serious infection.

3. Check all controls and operating functions of the machine in a safe area before starting to work.

## DURING OPERATION

1. Always wear seat belts when operating a motor vehicle.
2. Ensure everyone is clear of the machine, especially away from blind areas of the operator, before starting, actuating hydraulics or operating this equipment.
3. Do not plow snow at excessively high speeds.
4. Avoid hitting objects that will damage your plow or truck.
5. Set the brakes and stop the truck's engine before adjusting or servicing your plow.

## AFTER OPERATION

1. Park the plow on a solid, level surface. Fully collapse the lift cylinder with the upper lift links before unhitching the plow to prevent the plow frame from falling forward.

# OPERATING PROCEDURES

## ATTACHING THE PLOW

Attachment prongs on the truck should be mounted such that the bottom edge of the prongs measure about 10 inches above the ground. Prong receivers on the plow frame should remain parallel to the ground and at the correct height by fully retracting the lift cylinder with the upper lift links before removing the plow from the truck (See “Removing the Plow”). Ideally, the prongs on the truck should lift the plow frame slightly when driving into the plow for attachment.

Powdered graphite applied on the prongs will help the plow slide on and off more easily.

Check that the prongs are in line with the receivers. Set the parking brake in the truck to prevent it from creeping back out from the receivers.

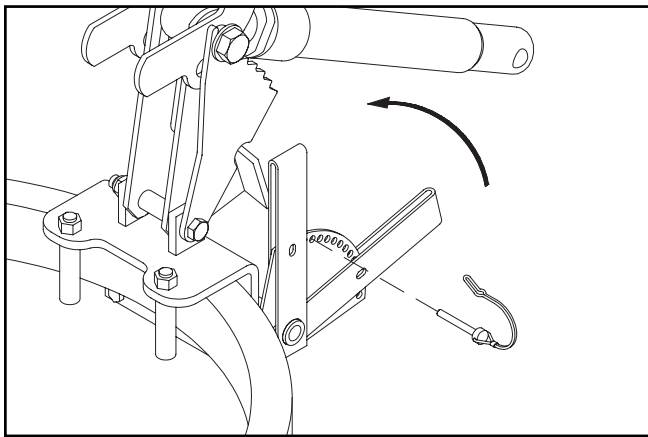

DWG NO. 5617A

Remove the tab lock pin from the parking stand index plate to raise the stand to its highest position. Reinstall the pin in the plate for transport.

Pull the latch handle into the clevis on the lift frame to force the sliders through the notches in the prongs and receivers. Check that both sliders are fully engaged.

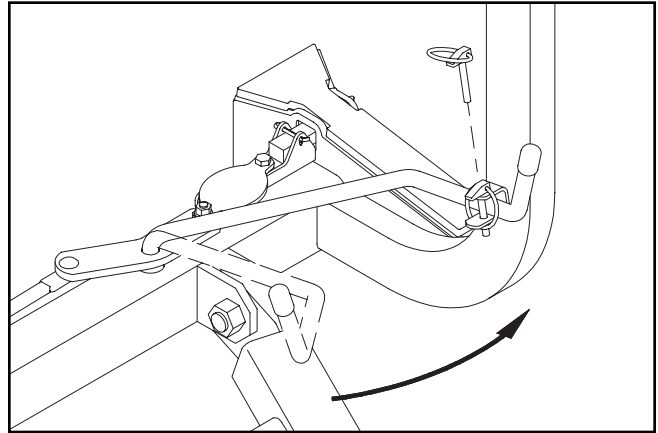

Handle Pinned With Plow On Truck DWG NO. 6721A

Pin the handle in the clevis with its klik pin. Failure to pin the handle in place may allow the plow to fall off the truck.

**NOTE:** Before connecting the plow’s wiring to the truck, make sure power is switched “Off” on the joystick controller.

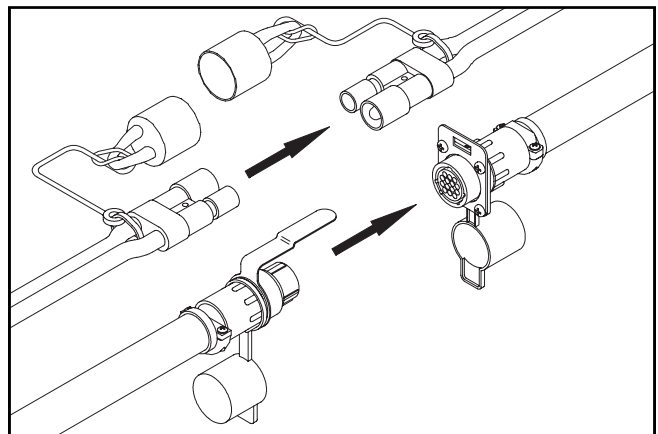

Alignment Tab and Slot

DWG NO. 6697

Plug in the two electrical connectors between the plow and the truck after latching the plow. The alignment tab on the 16-pin plug will mate with the slot on the mating receptacle to ensure proper connection.

Check that the plow headlamps and turn signals are operational, and headlamps are aimed correctly. Test the lift and angling cylinders in a safe area before using the plow.

To make alignment of the plow easier in the future, mark a point on the back of the head lamp, a point on the hood near the front of the truck and a point on the windshield that are in line when you are seated behind the steering wheel. Line up these three points when driving into the plow.

### THE JOYSTICK CONTROLLER

The joystick control box has slide switches for controlling power to the snowplow and for switching from the truck headlights to the headlights on the plow.

The joystick controls the left and right angling functions of the snowplow, and also controls the raising and lowering of the plow. Two push button switches are used to curl and uncurl the plow blade.

**NOTE:** Drawings 4162 and 4163 show the raise and lower functions of the joystick controller as received from the factory. Functions may be reversed to suit the preference of the operator by following the instructions on page 25 for switching the controller joystick and face plate.

The vehicle's electrical power must be turned on before the control box will function.

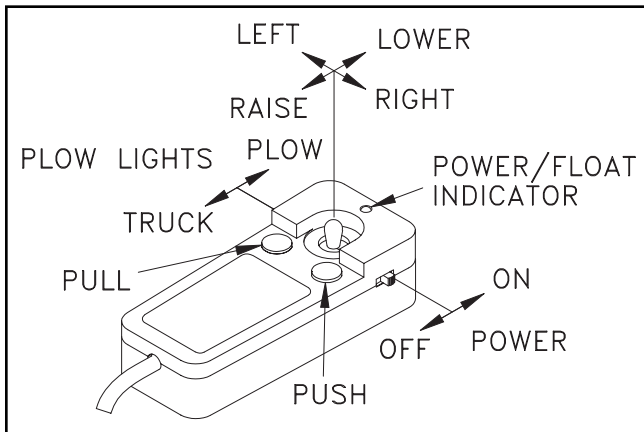

Joystick Control Box

DWG NO. 4162

Place the on/off switch on the joystick control box in the "On" position to supply power to the snowplow. A green light will indicate power is on.

Move the headlight slide switch on the control box to the "Plow" position to change from the truck lights to the snowplow lights. Activate high beam/low beam and turn signal/parking lamps from the truck as you normally would without the plow attached.

**NOTE:** When removing the plow, remember to place the headlight switch in the "Truck" position to return power to the truck's headlights.

Raise or lower the plow by moving the joystick to the "Raise" or "Lower" position. Hold the plow at an intermediate height by releasing the controller from the "Raise" position when the plow reaches the desired height. Moving the controller to the "Lower" position will lower the blade to the ground and allow the plow to "Float" along the contour of the ground while plowing snow.

The green light on the control box will turn yellow to indicate the plow is in the float mode. Momentarily moving the joystick to the "Raise" position will remove the plow from the float condition and the yellow indicator will return to green.

Move the joystick left or right to angle the blade. Release the joystick when the blade is at the desired angle.

Curl the plow blade forward by pushing the left hand button on the control box. Uncurl the blade by pushing the right hand button. Release the button to hold the blade at an intermediate position between full forward or full back.

The blade will move more freely if the curl and uncurl functions are done with the plow in the raised position to avoid resistance from the ground.

### TRANSPORTING THE PLOW

The extra weight of the snowplow on your truck will impair handling response and increase braking distance.

The plow will also block some airflow to the vehicle's cooling system, possibly causing the vehicle to overheat. Therefore, it is important not to exceed speeds above 45 mph when the plow is attached. Remove the plow if you must drive your truck for long distances when the temperature is warm.

Adjust the height, angle and curl of the blade to avoid blocking the headlights before transporting the plow.

Transport the plow with power to the joystick control box switched off to prevent accidental lowering of the plow. Never adjust the blade height or angle the blade while driving.

## PLOWING SNOW



**WARNING:** Always wear a seat belt when plowing snow. Sudden contact with a hidden object can result in serious personal injury.

Inspect areas to be plowed before snowfall for potential hazards, and mark obstructions with stakes that will be seen when snow covers the ground. Identify any emergency equipment and utility outlets that may need to be cleared in the event of a storm. Prepare a plan beforehand for clearing snow from tight or enclosed areas and locate sites for stacking snow.

Adjust the skids at the back of the moldboard according to the surface to be plowed. The bottom of the skids should be about 1/2" below the cutting edge when plowing gravel roads or lots. Skids should be even with the cutting edge on hard surfaces such as asphalt or concrete.

Always plow snow as it is accumulating. Wet snow may weigh about 12 pounds per cubic foot. The weight of snow being pushed by your plow may increase to several tons.

Allowing snow depth to grow to unmanageable levels can cause difficult removal problems and can be costly in terms of wear on equipment.



**WARNING:** Serious personal injury can result from plowing at excessive speeds, as well as costly damage to equipment and property, if an obstruction is encountered while plowing. Do not exceed 10 mph while plowing.

Plow snow in the lowest truck gear to transfer maximum power to the cutting edge. Clear areas in front of buildings first.



**WARNING:** Serious damage to the snowplow will result if an obstruction is encountered while driving forward with the blade curled. Do not attempt to push snow when the upper cutting edge is curled forward or on the ground. Never attempt to drive forward when the upper cutting edge is not visible from the cab.



**CAUTION:** Prevent premature wear or damage to the plow by only backdragging snow with the plow blade straight across the truck. Do not angle the plow when the upper edge is rolled over for pulling snow.

To backdrag snow away from a building, straighten the plow across the truck. Raise the plow with the joystick controller. Curl the upper edge forward with the LH controller button until the tip of the upper cutting edge is barely visible from the cab.

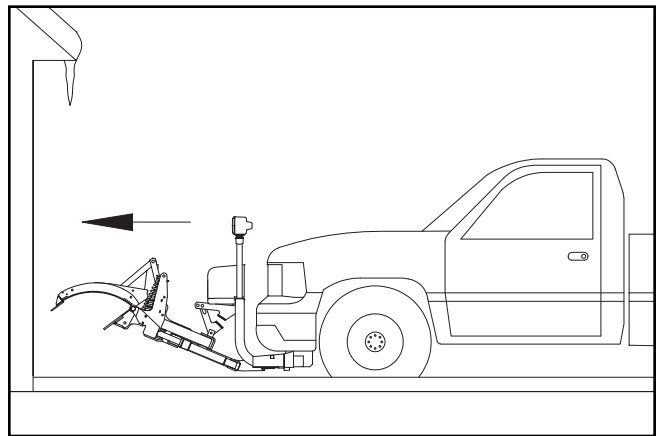

DWG NO. 5411

Slowly drive to the building, then shift the vehicle transmission to neutral.

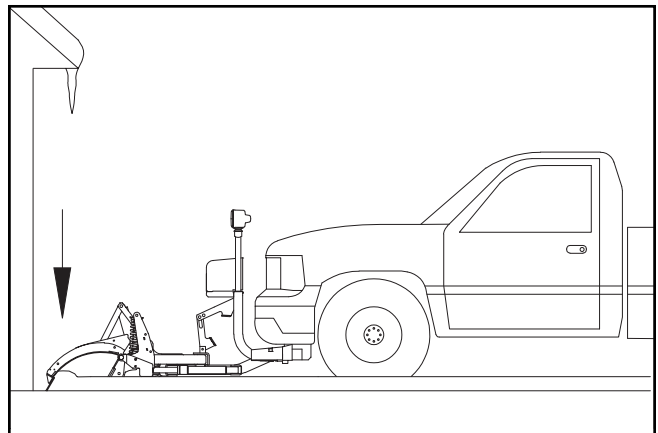

DWG NO. 5412

Lower the plow to the ground with the joystick controller.



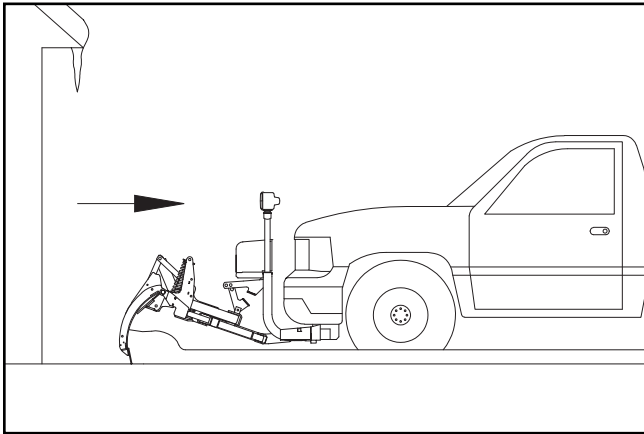

DWG NO. 5413

Curl the plow fully forward with the LH controller button. Shift the vehicle transmission into reverse and pull snow away from the building.

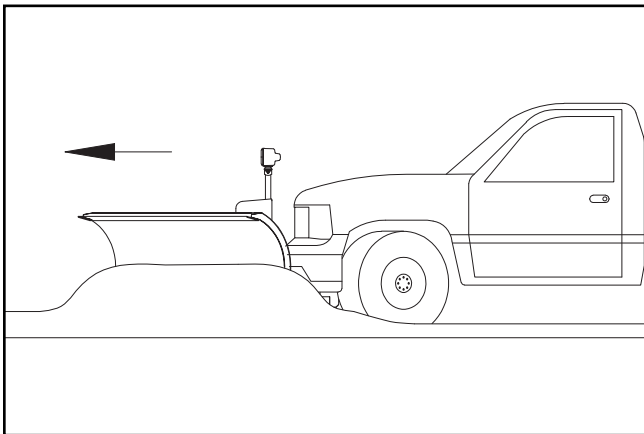

DWG NO. 5414

Raise the plow slightly, then uncurl the blade with the RH controller button. Push the snow to a clear area.

Clear large lots by angling the blade and creating a single path. Roll snow to outer edges of the lot by taking successive passes with the blade angled.

When plowing very deep snow, it may be necessary to raise the blade and shear off layers of snow until a working area is cleared. Work small areas in multiple passes to push snow to outer edges. Generally, 6 inch snow can be plowed with the entire blade width; 9 inch snow with 3/4 of the blade width; 12 inch snow with 1/2 of the blade width. Local conditions will determine how much work can be done before stalling or getting stuck.

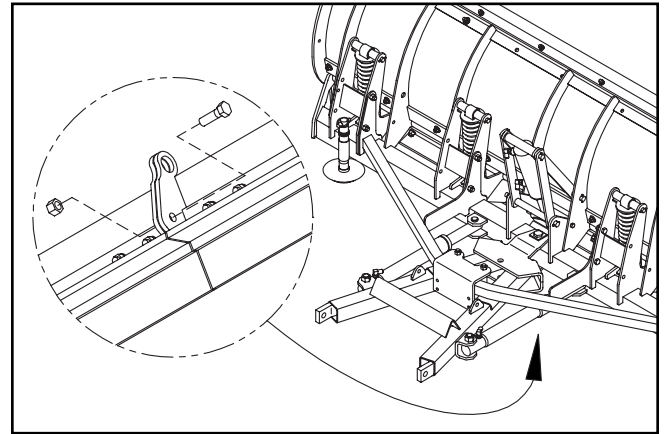

DWG NO. 5469

The two lower cutting edges may be bolted together to function as a single edge, if desired, by installing a 5/8" grade 5 bolt (not supplied) through holes in the support plates on the back of the trip edge sections. The cutting edge will trip harder when an obstruction is hit when the two sections are bolted together.

### PARKING

Lower the plow to the ground when parking your truck for a long period of time with the plow attached. Place the on/off switch in the "Off" position to prevent the plow from drawing power from the truck battery. The plow's power unit may continue to draw electrical current from the truck battery if the control switch is left on; possibly resulting in insufficient charge to start the truck.

### REMOVING THE PLOW

To remove the snowplow from your truck, park on a solid level surface with the blade straight, across the truck. Lower the plow to the ground and leave the controller in the "Float" mode.

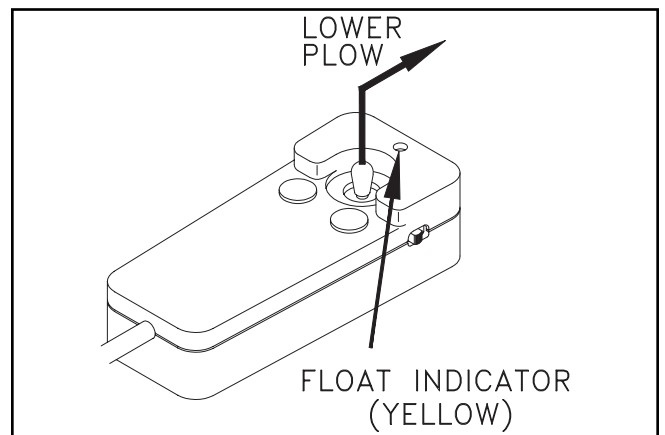

Lower Plow, Leave Controller in "Float" DWG NO. 4163

## 8 Operating Procedures

**NOTE:** The plow control box must be in the "Float" mode to manually retract the cylinder rod. If the cylinder rod cannot be retracted with power on and the controller in float, loosen the packing nut on the lift cylinder up to 1-1/2 turns to reduce friction.

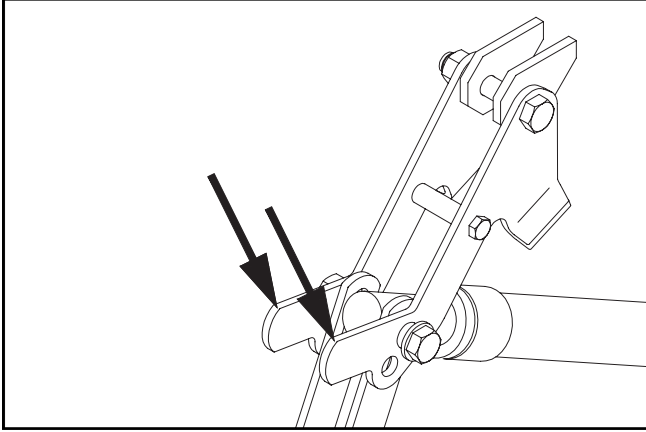

Retract Cylinder With Upper Lift Links DWG NO. 6000

With the plow lowered to the ground and the controller in the "float" mode, push down on the upper lift links to fully retract the lift cylinder rod.

Retracting the lift cylinder will orient the prong receivers correctly for reattaching the plow later. Failure to retract the lift cylinder rod will allow the lift frame to fall forward, possibly causing personal injury or damage to plow components.

Rotate the stop plate up to contact the spacer bushing on the lift cylinder bolt.

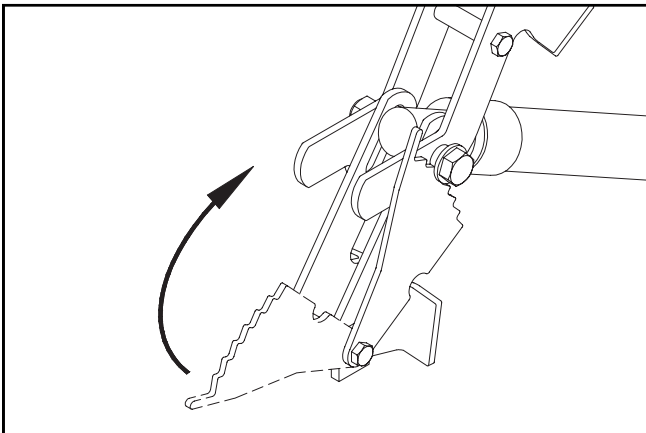

Rotate Stop Plate DWG NO. 6004

Gently push back on the headlight bracket to tilt the lift frame back as far as possible, then release the bracket to allow the weight of the lift frame to lock the stop plate in place.

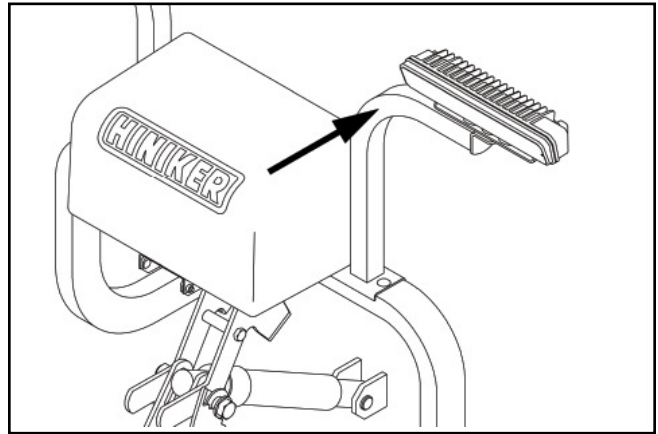

Push Lift Frame Back DWG NO. 6005C

Swing the latch handle open until the latch sliders are fully removed from the attachment prongs.

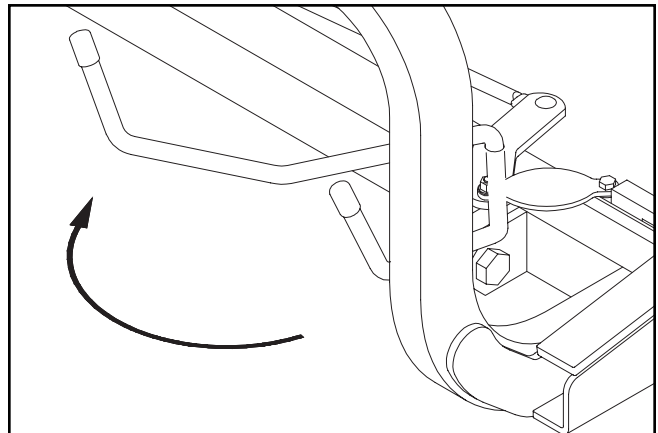

Swing Handle To Remove Sliders DWG NO. 6722A

Lower the parking stand to the ground by removing the tab lock pin from stand index plate, then swinging the stand to the ground with the lever.

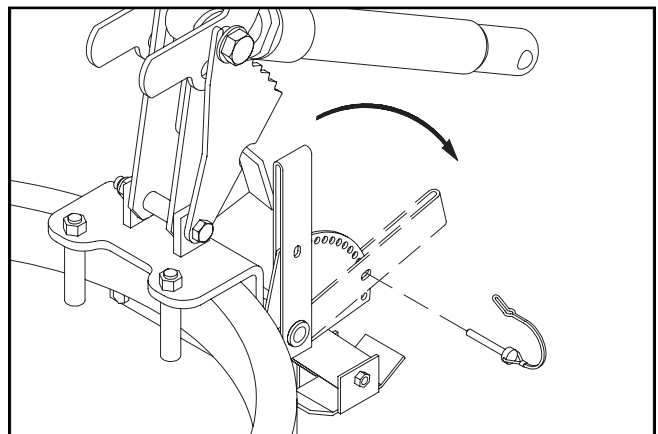

Lower and Pin Parking Stand DWG NO. 5251A

Reinstall the pin in the index plate through the hole in the lever to hold the stand in place.

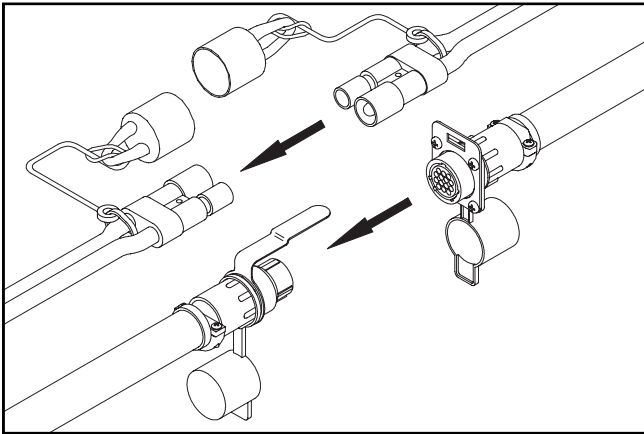

Disconnect Plugs

DWG NO. 6698

Disconnect the two electrical connectors by pulling them straight out from the receptacles. Do not twist the connectors, twisting will damage the connector pins or the wiring harness.

Place dust caps on connectors to prevent contamination.

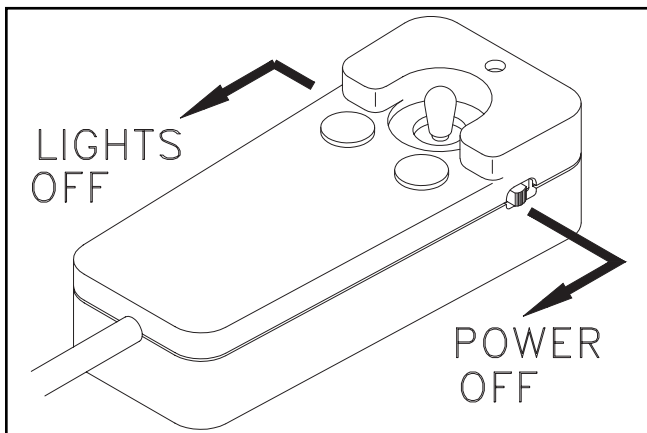

Turn Off Lights and Power

DWG NO. 4164

Back inside the truck, return control of the headlights to the truck and switch power off on the snowplow control box, then slowly back the truck out from the plow.

NOTE: The stop plate will automatically fall forward as soon as the lift cylinder is fully extended for raising the blade prior to transporting the plow.

If the snowplow won't be used for an extended period of time, the prong weldment can be removed from the truck by removing the hex bolts that fasten it to the truck mount frame.

## TROUBLE SHOOTING

### GENERAL

1. Check to see that the motor is wired correctly with tight connections, for the proper voltage.
2. Check reservoir oil level.
3. Check that wiring harness relay connections are wired correctly
4. Check for external leakage at cylinders, hoses and power unit.

PROBLEM	POSSIBLE CAUSE	REMEDY
1. Plow does not attach to vehicle	A. Receivers are tipped forward B. Prongs recoil out of receivers when attaching C. Park stand pinned too low	A. Fully collapse lift cylinder and rotate stop plate up to brace the lift frame before removing plow from truck. B. Slowly drive into receivers and set parking brake C. Lower receivers by adjusting park stand
2. Pump motor does not run	A. Defective solenoid B. Defective pump motor C. Weak or defective battery D. Bad electrical connections E. Defective joystick control box F. Blown fuse supplying power to control box	A. Replace solenoid B. Replace brushes or pump motor C. Charge or replace battery D. Clean and tighten connections E. Replace control box F. Replace fuse
3. Pump runs with joystick in neutral position	A. Defective solenoid B. Defective joystick control box C. Wiring short	A. Replace solenoid B. Replace control box C. Locate and repair
4. Plow will not lower	A. Reversed wiring on valve block B. Defective joystick control box C. Defective lift return valve or coil	A. Correct wiring B. Replace control box C. Replace valve or coil
5. Hydraulic cylinder does not function or functions slowly, motor runs.	A. Weak or defective truck battery B. Oil level low C. Hydraulic connection leak D. Solenoid valve not opening properly	A. Charge or replace battery B. Add oil (do not overfill) C. Tighten or redo connection D. Replace valve
6. Plow does not remain raised with joystick in "neutral" position	A. Leakage through pump check valve B. Leakage through solenoid lowering valve C. Internal leakage in cylinder D. Defective joystick control box	A. Clean valve, or replace B. Clean valve, or replace C. Repack or replace cylinder D. Replace control Box

<b>PROBLEM</b>	<b>POSSIBLE CAUSE</b>	<b>REMEDY</b>
7. Angling cylinders relieve too easily or too difficulty while plowing	A. Relief pressure set too low or too high	A. Have relief pressure adjusted by Hiniker snowplow dealer
8. Oil leaks from cylinder(s)	A. Loose packing B. Defective cylinder	A. Tighten packing 1/8 turn B. Repack or replace cylinder
9. Battery goes dead with power to the control box on and joystick in neutral position.	A. Short in wiring B. Defective joystick control box	A. Locate and repair B. Replace control box
10. Battery goes dead with power to the control box off.	A. Short in wiring	A. Locate and repair
11. Plow parking/turn lights are dim	A. Bad connection(s) B. Lights not properly grounded	A. Repair connection B. Properly ground
12. Plow does not clean-up snow from low areas	A. Controller not in float mode	A. Controller should be in the float mode
13. In extremely cold temperatures, the oil in the hydraulic system is thickened, causing slow functioning of the plow	A. Cold temperatures	A. As the system warms, the oil will thin out and function normally B. Select Hiniker Cold Flow Hydraulic Oil for plowing in extremely cold temperatures
14. Pump chatters when raising plow	A. Hydraulic oil low	A. Add hydraulic oil until chattering stops. Do not overfill
15. Oil running out of cap on hydraulic reservoir	A. Plowing on steeply inclined terrain B. Too much oil	A. Avoid excessive inclines or change direction of plowing B. Remove excess oil
16. Vehicle overheats with the plow on	A. Vehicle coolant level low B. Ice and snow buildup in grill C. Insufficient airflow to engine compartment	A. Add coolant B. Remove ice and snow C. Transport plow at lower speeds
17. Plow lights do not operate with plow attached	A. Light switch on joystick control box in "truck" position B. Defective relay C. Faulty light switch on joystick control box D. Blown fuse on vehicle accessory feed	A. Move switch to "plow" position B. Replace relay C. Replace joystick control box D. Replace fuse
18. Truck headlights do not operate properly with plow removed	A. Light switch on joystick control box in "plow" position B. Defective relay	A. Move switch to "truck" position B. Replace relay
19. Poly moldboard is bowing or cracking	A. Moldboard bolts are too tight.	A. Loosen the bolts so the plastic can expand and contract

# MAINTENANCE



**WARNING:** Do not service or otherwise handle a plow in the raised position unless it is securely blocked against unexpected falling. Likewise, bolt or pin ribs on the back of the moldboard to prevent unexpected rollover of the plow due to accidental loss of hydraulic pressure or cylinder removal.

Dependable snowplow operation is the result of following good maintenance procedures. Inspect your plow frequently to ensure that all parts are working smoothly, and develop a schedule for maintenance at required intervals.

## GENERAL

Wash salt and dirt off the plow before storage. Do not power wash hydraulic cylinders as high pressure can damage seals and cause cylinder failure. Touch-up any chips or scratches in the paint and apply a light coating of grease to extended cylinder rods to prevent corrosion.

## HYDRAULIC SYSTEM

The majority of snowplow operational problems are caused by bad oil in the hydraulic system. Hydraulic oil should be changed every year for best performance. Select Hiniker Cold Flow Hydraulic Oil or an equivalent oil that meets military specification 5606, for plowing in extremely cold temperatures.

To change hydraulic oil, first pin the upper and lower moldboard halves together through holes in the center moldboard ribs and center cylinder supports to prevent the upper half from falling forward when the hydraulic lines are removed.

Disconnect the electrical wiring harnesses from the power unit and uncouple five hydraulic lines. Unbolt the power unit from the plow, and remove it to a clean working area that can capture any spilled oil.

Carefully unbolt the oil reservoir from the power unit and discard old oil. Purge old oil from the angling cylinders by forcing rods to retract.

Clean the suction filter at the pump inlet and wipe any metal shavings off the magnet on the pump.

Assemble the reservoir onto the power unit and fasten the power unit onto the snowplow before adding new hydraulic oil.

Reattach hydraulic hoses and electrical wires at the correct locations on the power unit.

Pour hydraulic oil into the power unit reservoir until the oil reaches the fill level.

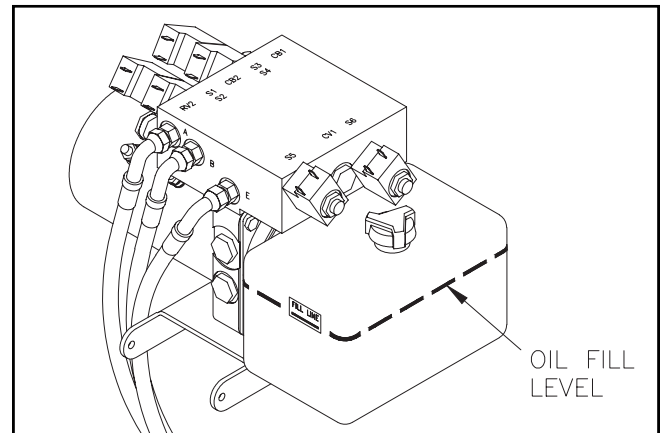

DWG. NO. 6470

Angle the plow full left and right to fill the angling cylinders with oil. Add more oil to the reservoir until the oil again reaches the fill level.

Un-pin the upper and lower moldboard halves. Cycle the plow left and right, up and down, and work the curl mechanism to purge any air trapped in the system.

Check the oil level with the plow on the ground and the blade uncurled. Add oil to the fill level, if necessary, but do not overfill the reservoir.

## MECHANICAL COMPONENTS

Prior to the operation of a new snowplow, or one which has been stored, inspect all hardware and verify proper torque on all bolts and nuts in accordance with the recommended torque specifications.

### GRADE 5 TYPE B & F LOCK NUT TORQUE VALUES

Diameter	Ft-lbs.	N-m
5/16"	13-18	17-25
3/8"	23-33	31-44
1/2"	58-82	79-112
5/8"	117-165	158-223

### GRADE 5 BOLT TORQUE VALUES\*

Size	Ft-lbs.	N-m
1/4"	8-12	11-16
3/8"	29-41	39-56
1/2"	73-103	99-140
5/8"	146-206	198-279

\*Applications without lock nuts.

Loose bolts can cause hole elongation and part failure resulting in dangerous operating conditions and equipment breakdown.

Check all hardware periodically during operation and keep tightened to specified torque values. Replace worn bolts and lock nuts with grade 5 bolts and equivalent type B or type F lock nuts. Type B lock nuts are plain hex; type F lock nuts are flanged hex.

Inspect wear of the cutting edges before every plowing season and frequently throughout the season. Replace cutting edges before wear reaches the main plow blade.

The 5/16" hex bolts in the latch sliders are factory retained with anaerobic threadlock. If removal or replacement of these bolts is necessary, purchase new bolts with threadlocker from your Hiniker dealer, or apply a commercially available threadlock, i.e., Loctite 242 (blue) or Perma-Lok HM118 (red), to standard 5/16-18 X 3/4" grade 5 hex bolts before reassembly.

## ELECTRICAL MAINTENANCE

Periodically check all electrical connections for proper fit and remove any contamination that may be present.

To prevent contamination always place dust caps on connectors when not in use. This is particularly important when the plow is being stored. A light coat of dielectric grease is recommended to reduce corrosion of the contacts and to make connecting and disconnecting easier.

Before each season check vehicle battery and electrical system for proper operation. A weak battery, dirty terminals, or faulty charging system may cause improper operation and possible failure of the joystick controller.

Before every plowing season, and throughout the season, check the snowplow headlamps for proper function and aim. Refer to sections titled "System Check-Out" and "Headlamp Aiming Procedure" in this manual for instructions.

# FLOW ASSEMBLY

## GENERAL INFORMATION



**WARNING:** To prevent personal injury or death, be certain to keep clear of any parts that may drop when removing bundling straps, wires or brackets. Support heavy sections with a hoist or blocks before removing wires or straps.

In the following instructions, left and right machine references are defined as being viewed from the cab of the truck.

Be certain that hydraulic hoses and electrical wires are safely routed and allow full motion of moving parts. Secure loose wires with plastic tie straps.

Some components are fastened at incorrect locations for shipping purposes.

All hardware should be tightened only enough to ensure safety during assembly. Torque hardware to specified values, as shown in the following chart, only after assembly has been completed.

### GRADE 5 TYPE B & F LOCK NUT TORQUE VALUES

Diameter	Ft-lbs.	N-m
5/16"	13-18	17-25
3/8"	23-33	31-44
1/2"	58-82	79-112
5/8"	117-165	158-223

### GRADE 5 BOLT TORQUE VALUES\*

Size	Ft-lbs.	N-m
1/4"	8-12	11-16
3/8"	29-41	39-56
1/2"	73-103	99-140
5/8"	146-206	198-279

\* applications without lock nuts

Replace worn bolts and lock nuts with grade 5 bolts and equivalent type B and type F lock nuts. Type B lock nuts are plain hex; type F lock nuts are flanged hex.

## FLOW ASSEMBLY

- Place the moldboard face down on cardboard or other padding that will prevent scratches in the paint. Remove both skid assemblies from their shipping locations and reassemble at the ends of the moldboard with one 1" spacer and one 1/2" spacer beneath the moldboard tube.

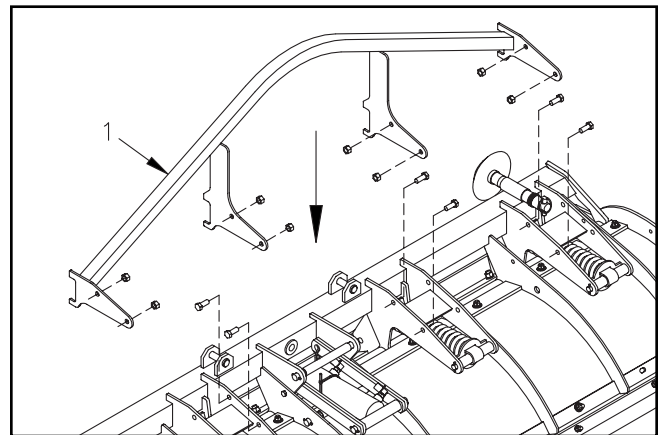

DWG NO. 5470

Wrap hoist straps or padded chains around the quadrant weldment, item 1 in drawing 5470, to support its weight.

Unbolt the quadrant from the back of the moldboard assembly by removing eight hex bolts and lock nuts. Rotate the quadrant to its working position and line up eight holes with holes into moldboard. Reassemble the quadrant to the moldboard with the eight hex bolts and lock nuts previously removed.

- Open the frame crate and set aside the power unit box, headlamp boxes and parts box for later. Carefully lift the frame assembly from the crate by wrapping hoist straps or padded chains around both ends of the 2 1/2 inch square tube at the back of the frame assembly.

Remove the 3/4 inch hex bolt, arrow 1 in drawing 5420A, and two 1/2 inch hex bolts and spacers, arrow 2, from the push frame.



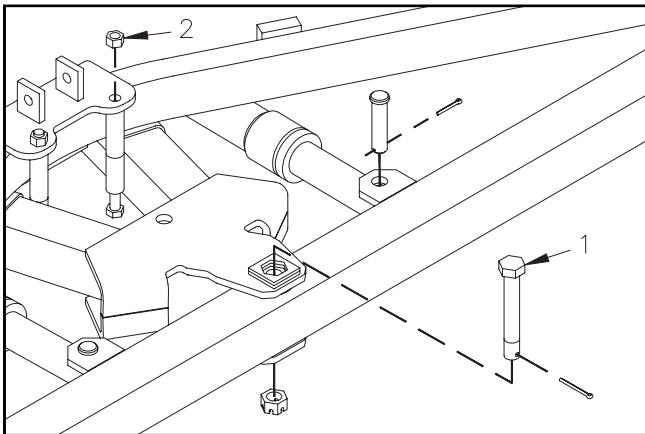

DWG NO. 5420A

Align the push frame hitch plates with the pivot hole in the moldboard tube, then reassemble the 3/4 inch hex bolt, slotted nut and cotter pin. Install the nut so that the assembly is secure, but frames will pivot.

Reassemble the two 1/2 inch hex bolts, spacers and lock nuts at their original locations and fully tighten hardware.

Remove clevis pins from the rod ends of the two angling cylinders. Loosen the plugs in the cylinder ports and extend the cylinder rods to the lugs on the back of the moldboard. Pin the rods between the lugs with the clevis pins and cotter pins.

3. Tip the moldboard and frame assembly to its working position with a hoist or fork truck. Pin the parking stand to hold the square tubes of the push frame parallel to the ground.

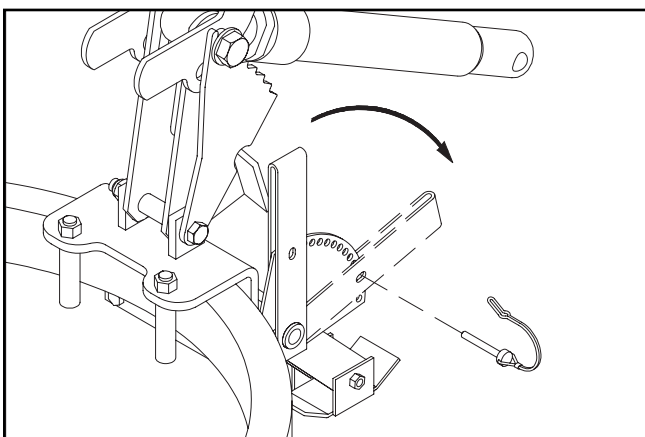

Lower and Pin Parking Stand

DWG NO. 5251A

Swing the lift frame up to its approximate working position and hold it with a hoist or forklift for assembly of the lift mechanism. The bottom surface inside the two prong receiver channels should measure approximately 10

inches above the ground in the working position.

4. Locate a 90° O-ring/flare adapter in the hardware bag and the lift cylinder in the parts box. Turn the O-ring end into the port of the lift cylinder so that the flare end is toward the rod end of the cylinder when tightened.

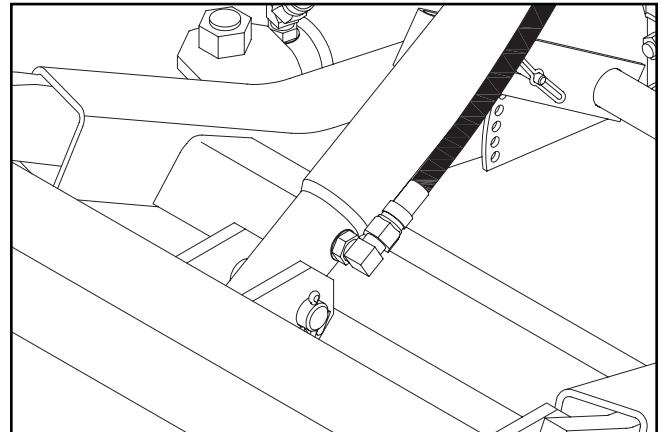

DWG NO. 4202

Pin the base of the cylinder between the center lugs of the lift frame with the 3/4 inch x 3 inch clevis pin. The hydraulic fitting should be on the right side of the cylinder.

Remove four lift links and the stop plate kit from the parts box. From the hardware bag remove two 3/4 inch hex bolts, two 3/4 inch I.D. shim washers and one 3/4 inch nylon insert lock nut. Also remove the 1/2 inch hex bolt and upper link spacer bushing.

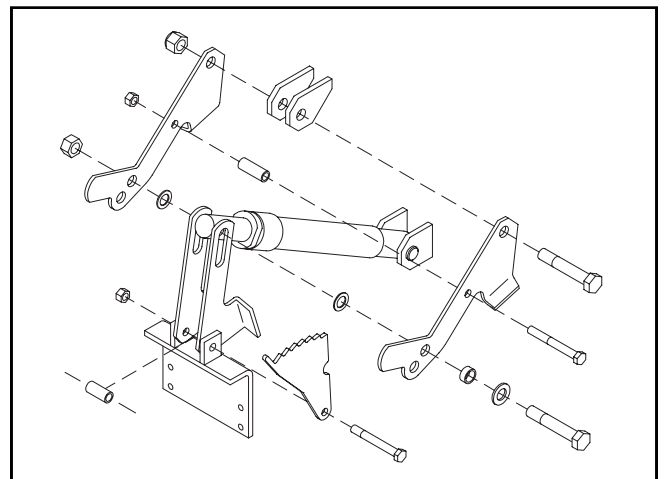

DWG NO. 6585

Identify the RH and LH upper and lower links by referring to drawing 6585. Assemble the links with their stop surfaces away from the lift cylinder.

Remove the 1/2 inch hex bolt and spacer from between the tabs on the push frame. Slide the stop plate onto the bolt, as shown in the drawing, then bolt the two lower links inside the tabs, with the spacer between the links.

Assemble the two upper lift links outside the lugs on the lift frame with a 3/4 inch x 4 1/4 inch hex bolt and nylon insert lock nut.

Bolt the upper link spacer bushing between the two upper links with the 1/2 inch hex bolt and lock nut.

Place the flat washer and spacer bushing from the stop plate kit onto the remaining 3/4 inch hex bolt, then complete the lift mechanism assembly by bolting the lift cylinder rod, lower links and two shim washers between the upper links.

Bolt through the upper set of bottom holes in the upper links for most vehicles, then secure the assembly with the 3/4 inch lock nut from the stop plate kit. Bolting through the lower set of holes will increase downward plow travel for taller trucks, but reduce lift height.

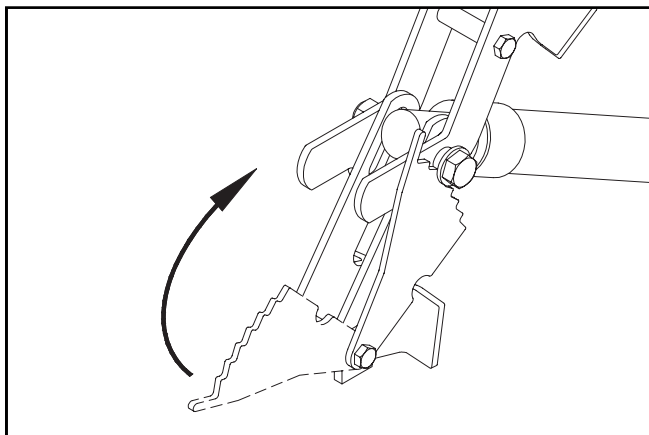

DWG NO. 6004

Rotate the stop plate up to contact the spacer bushing on the lift cylinder bolt. Gently push back on the upper lift frame tube, then release to allow the weight of the frame to lock the stop plate in place.

5. Snip the three plastic tie straps holding the rollover cylinder and links to the back of the moldboard assembly.

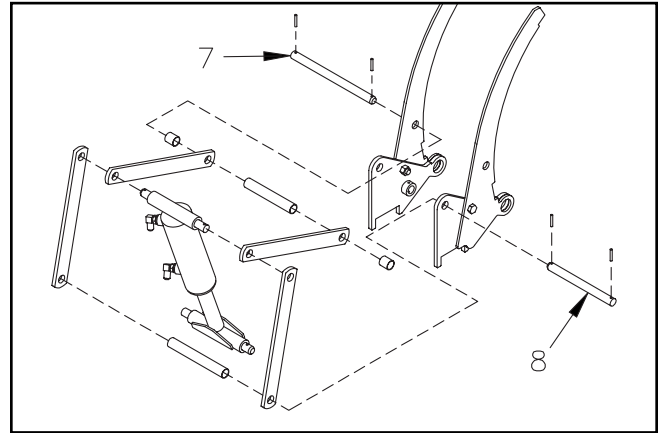

DWG NO. 5472

Drive the spring pin from the chamfered end of pin #7 in drawing 5472, then remove the pin and three spacers.

Extend the rollover cylinder until holes in the two inner links can be assembled to holes in the moldboard ribs.

Pin the inner set of links between the ribs, with the long spacer between the two links and a short spacer between each link and rib. Reinstall the spring pin to secure the assembly.

Drive the spring pin from the chamfered end of pin #8, then remove the pin and the spacer.

Assemble the outer set of links between the two frame plates, with the spacer installed between the two links. Reinstall the spring pin to secure the assembly.

6. Before assembling the power unit on the lift frame, scrape a small amount of paint from the two mount holes in the lift frame to provide a good electrical ground for the turn signals and parking lights.

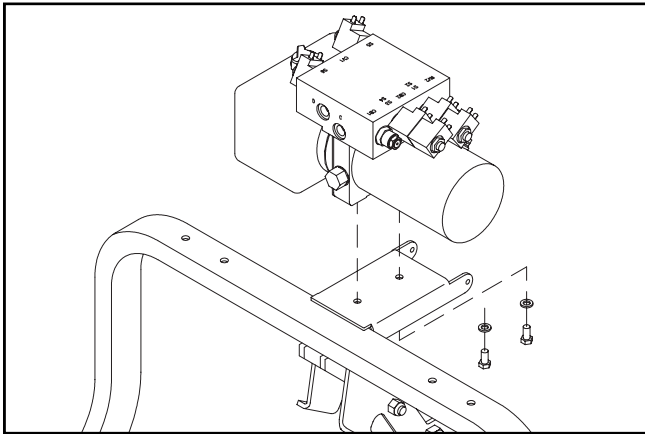

DWG NO. 6463

Mount the power unit on the lift frame with two 3/8 inch x 3/4 inch hex bolts and two 3/8 inch lock washers. The plastic reservoir of the power unit should be to the left side of the plow.

Locate the five straight O-ring/flare hydraulic fittings in the hardware bag. Install the O-ring ends of the five straight fittings into the five ports in the power unit.

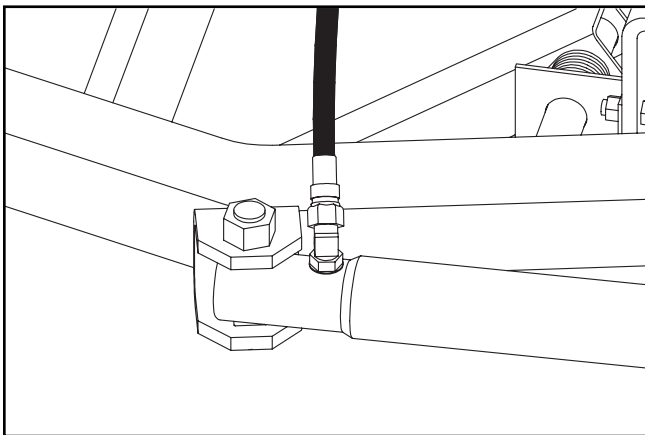

DWG NO. 4205

Locate two 45° O-ring/flare hydraulic fittings in the hardware bag, and install them into the ports of the angling cylinders so that the flare ends are nearly parallel to the mount lugs of the push frame.

Identify five hydraulic hoses in the parts box. The two longest hoses measure 66 inches long, one hose is 54 inches long and the two shortest hoses are 33 inches long.

The 54 inch long hose connects port A on the power unit to the LH angling cylinder. Connect the 90° hose end to port A, then route the hose along the cross brace at the rear of the push frame before connecting the straight end to the cylinder. Secure the hose to the brace with plastic tie straps. Refer to drawing 6465.

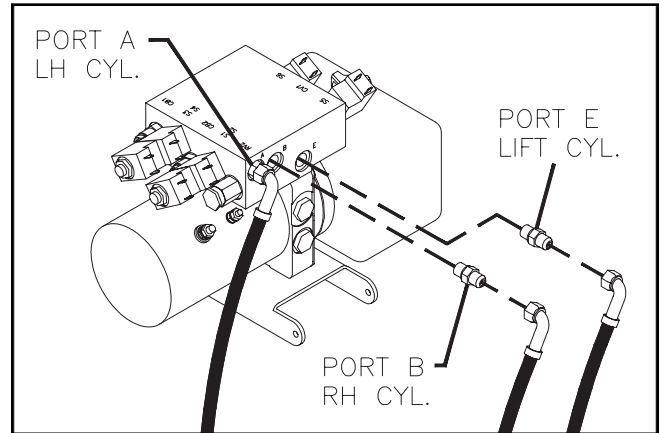

DWG NO. 6465

Connect one of the 33 inch long hoses between port B on the power unit and the RH angling cylinder. Connect the last 33 inch long hose between port E on the power unit and the lift cylinder.

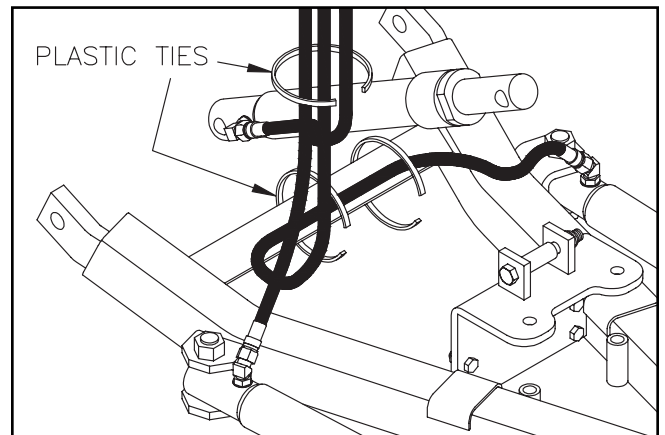

DWG NO.5661

Strap the three hoses from the angling and lift cylinders together with a plastic tie, as shown in drawing 5661.

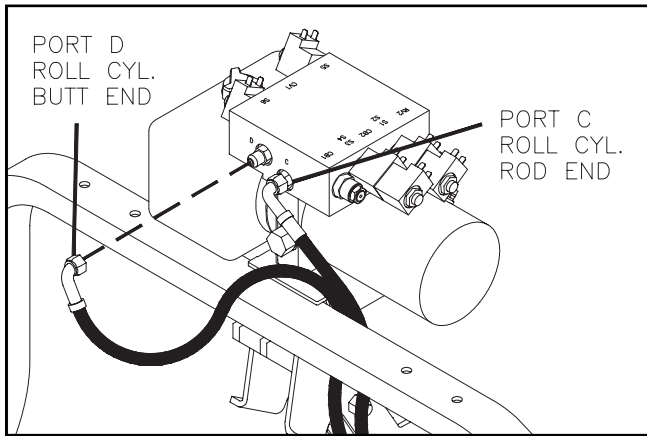

DWG NO. 6461

Route the two 66 inch long hoses through the hose loop on the push frame and ahead of the lift frame tube so that the 90° ends are toward the power unit and the straight ends are toward the rollover cylinder on the back of the moldboard.

Assemble one of the hoses between port C on the power unit and the rod end of the rollover cylinder. Connect the last hose between port D and the butt end of the rollover cylinder.

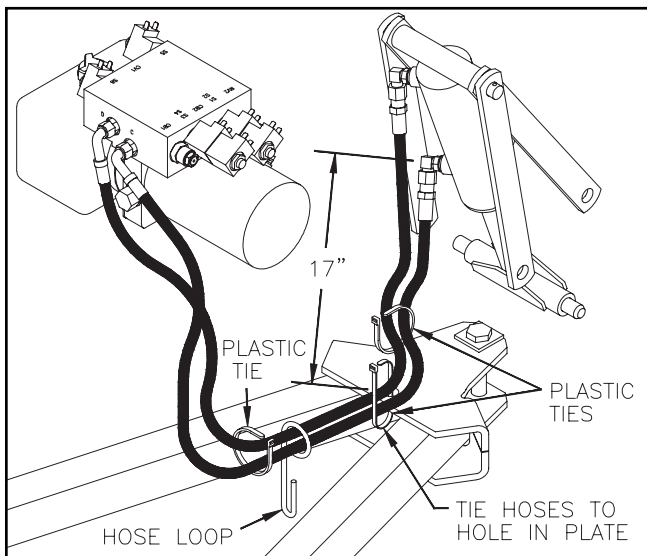

DWG NO. 6462

Band both hoses to the hole in the upper plate of the push frame with a plastic tie strap, leaving about 17" of hose between the rod end cylinder port and the tie strap. Also band the hoses together just ahead of the first tie and just behind the hose loop.

7. Mount the headlamp brackets to the lift frame tube with four 3/8 inch x 2 inch carriage bolts and flanged lock nuts from the hardware bag in the parts box.

Remove the LH and RH headlamps from their boxes and mount on the brackets with hardware from the headlamp boxes.

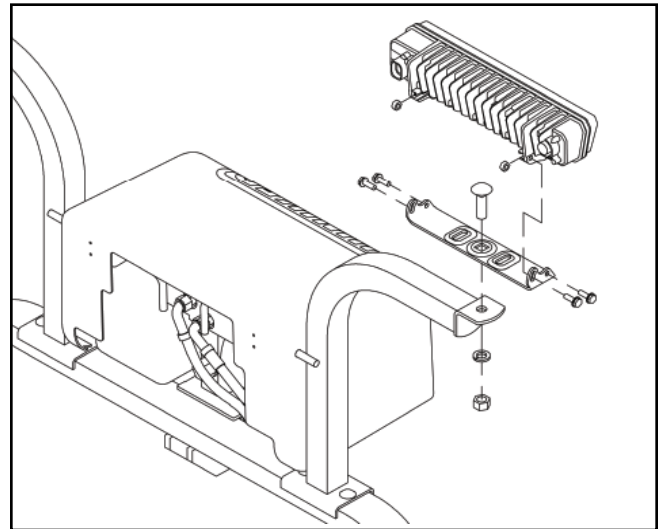

DWG NO. 6469C

Refer to sections titled "System Check-Out" and "Headlamp Aiming Procedure" in this manual for aiming instructions.

8. Identify the plow power cable assembly and the plow wiring harness in the parts box. The power cable for the snowplow has two cables with ring terminals on one end and a two pin connector on the other, and measures about 38 inches long.

The plow wiring harness has a 16-pin connector on one end and the other end has connectors labeled "DRIVER SIDE" and "PSNGR SIDE" for the headlamps, and six loose wires with spade receptacles.

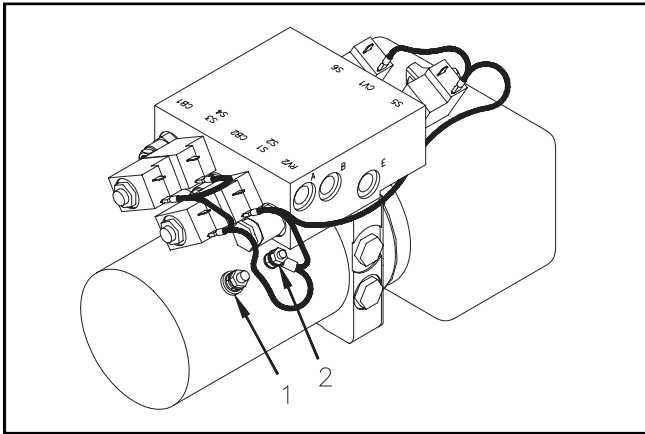

DWG NO. 6468

**NOTE:** To prevent corrosion lightly coat all electrical connections, rings and spade terminals with dielectric grease prior to assembly.

Attach the ring terminal of the solid red (or red striped) wire of the power cable assembly to the terminal on the power unit at location 1 in drawing 6468.

Locate the coil ground harness in the power unit box. Connect the harness to the coils as shown in drawing 6468.

Fasten the ring terminal of the solid black wire of the power cable assembly, and the ring terminal of the coil ground harness to the terminal on the motor at location 2.

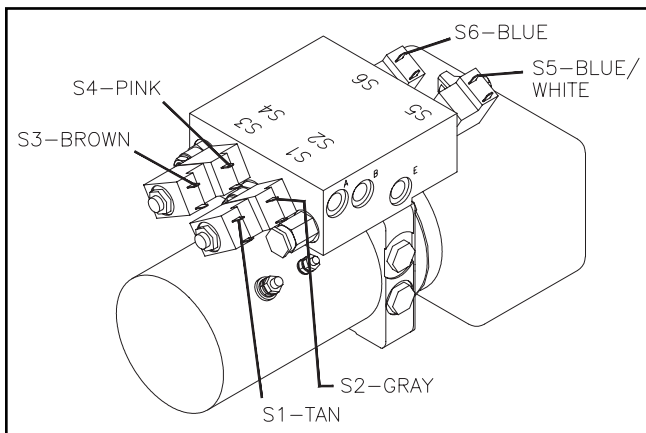

DWG NO. 6466

Connect the Tan wire of the plow wiring harness to the spade terminal on solenoid S1.

Connect the Gray wire to solenoid S2.

Connect the Brown wire to solenoid S3.

Connect the Pink wire to solenoid S4.

Connect the Blue with White Stripe wire to solenoid S5.

Connect the Blue wire to solenoid S6.

Connect the RH headlamp to the harness end labeled "PSNGR SIDE" and the LH headlamp to the end labeled "DRIVER SIDE".

Use plastic tie straps to band headlamp cables to the brackets at location 3 to provide clearance for the power unit cover rods later.

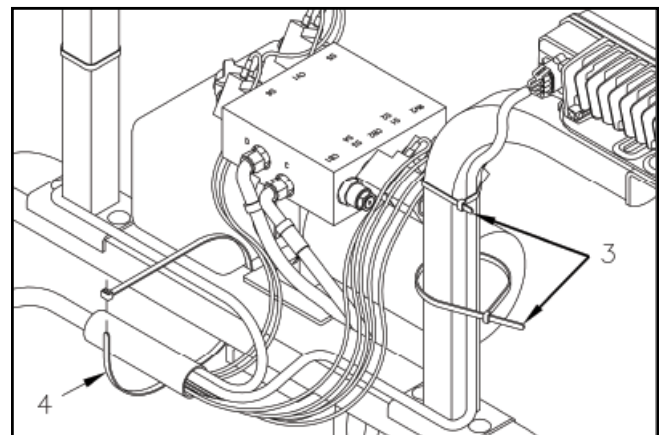

DWG NO. 6464B

Band the plow wiring harness to the frame tube with a plastic tie strap, as indicated in the drawing 6464B at location 4. Refer to the drawing for routing wires to the power unit and headlamps.

**NOTE:** Install the plow harness so that water does not run down the wires and pool inside the "Y" connection. Position the harness so that any trapped water can easily drain away.

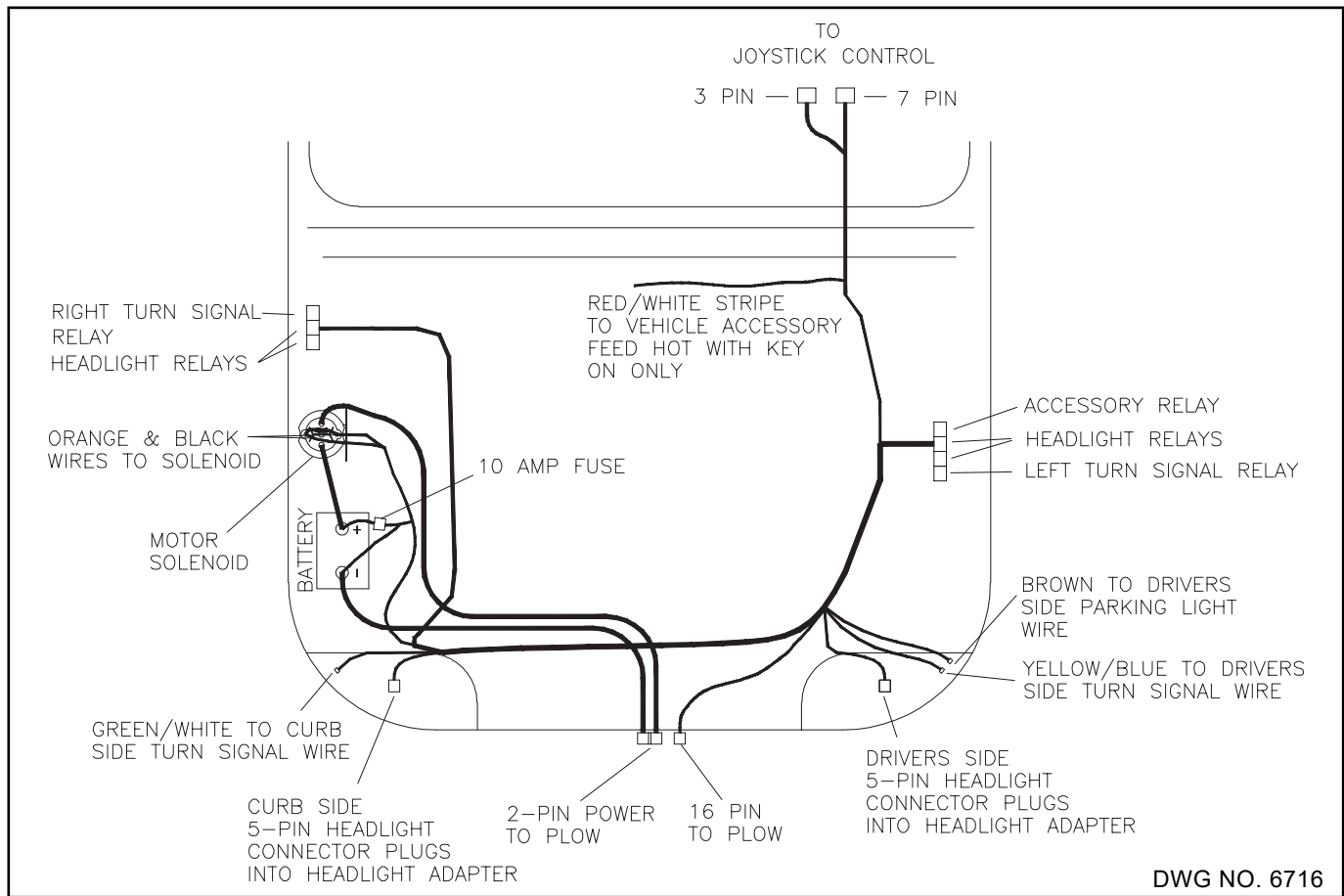

Truck Battery On Passenger Side



**WARNING: Disconnect truck battery before beginning electrical installation to avoid shock hazard.**

The motor solenoid, underhood wiring harness, power cable and joystick control box are located in the parts box shipped with the snowplow frame.

**NOTE:** Lightly coat electrical connectors, ring and spade terminals with dielectric grease before installation to prevent corrosion

9. Refer to drawing 6716. Lay the underhood harness in its approximate position for final assembly with the 7-pin and 3-pin circular connectors near the driver's side firewall. Place the 16-pin connector just left of center near the grill, the set of four relays near the driver's side inner fender and the other set near the passenger side inner fender. Place the 5-pin headlight connectors at the respective headlights.
10. Determine the location of the vehicle battery. If the battery is located on the right (passenger)

side or if there are two batteries configured as a 12 volt system, then proceed to step 11.

If the battery is located on the left (driver)side of the vehicle, then the wiring harness will need to be modified, as follows.

Refer to Drawing No. 6717.

Remove the tape from the Black corrugated loom at the points shown. Locate the Orange, Red, and two Black wires. These wires connect to the battery and pump solenoid. Remove the four wires from approximately 33 inches of the loom, making sure the Red and Black wires are long enough to connect to the battery. Tuck these wires back into the loom as shown in the drawing and retape the loom.

11. If there is no access hole in the drivers side firewall then drill a 1-1/8 inch diameter hole. Route the 7-pin and 3-pin circular connectors through the firewall into the cab compartment and install the 4 inch grommet in the hole, if required.

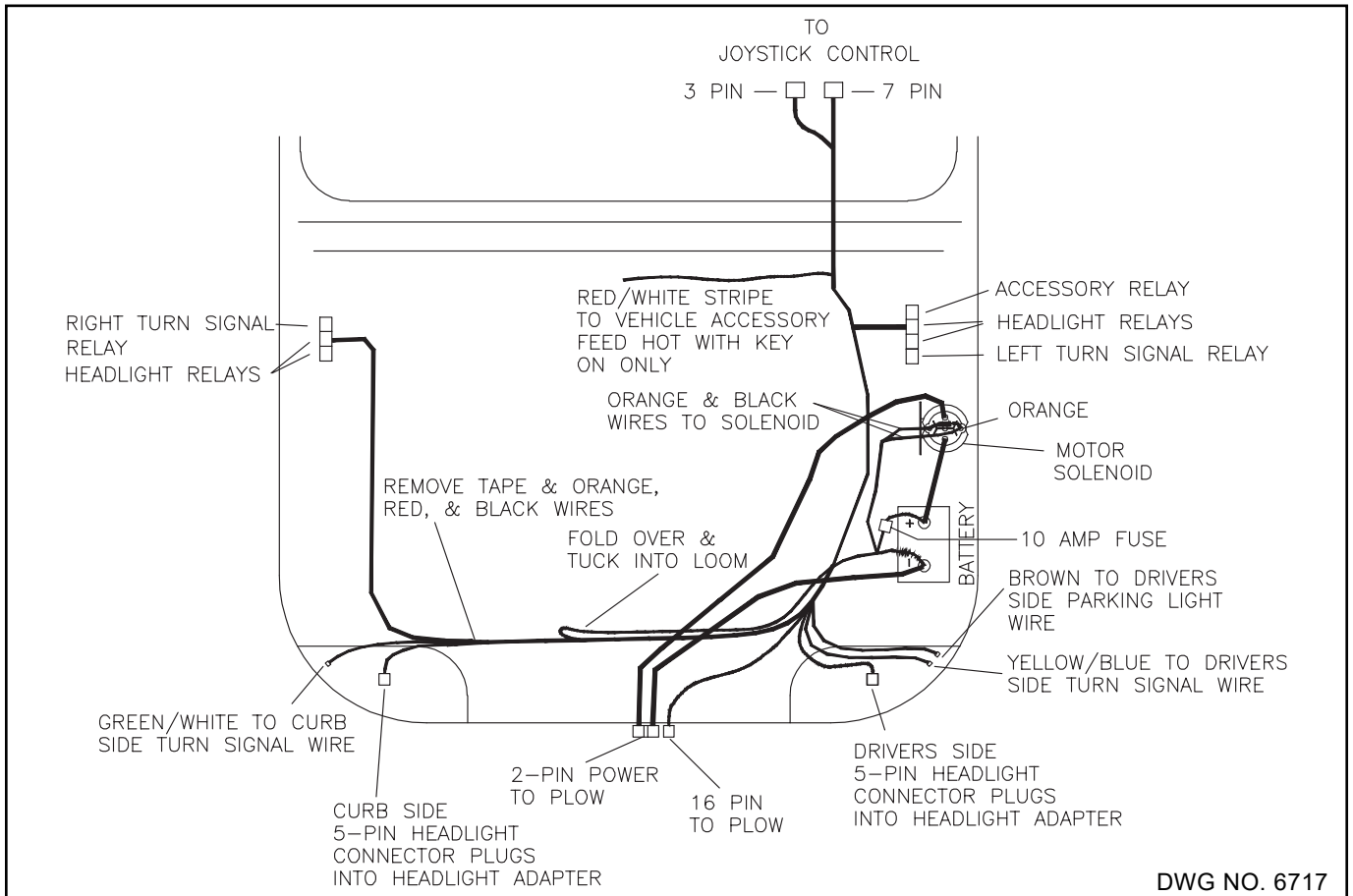

DWG NO. 6717

Truck Battery On Driver Side



**CAUTION:** Ensure that the relays will clear any hood lift/spring mechanisms before installation

12. Select an area near the driver's side inner fender to mount the four relay set. Drill two 1/8" diameter holes and secure the relays using #8 x 1/2" self-tapping screws from the hardware bag in the parts box. Apply a light coat of dielectric grease on the relays before inserting into holders.

**NOTE:** Always mount the relays with the wires pointing down to prevent contamination.

Repeat this procedure and mount the three relay set on the passenger side inner fender.

13. Splice the red with white stripe wire to the vehicle's switched 12 volt auxiliary electrical circuit. This will prevent operation of the plow without the vehicle key being on. This wire controls the accessory relay that powers the control joystick and solenoids.



**CAUTION:** To prevent injury or property damage caused by unintentional plow movement when the key is removed from the vehicle, the red/white striped wire must be connected to a switched power source on the vehicle. Connecting to a power source not controlled by the ignition switch will allow movement of the plow with the vehicle key removed.

14. Connect the joystick control box to the 7-pin and 3-pin connectors inside the truck cab. Secure the box at a safe location in the cab with the strip of hook and loop fastener.



**WARNING:** Ensure that the motor solenoid and associated wiring will clear any hood lift/spring mechanisms before installation.

**IMPORTANT:** Do not over tighten nuts on the motor solenoid terminals. Over-tightening causes premature solenoid failure. Refer to torque specifications on the solenoid.

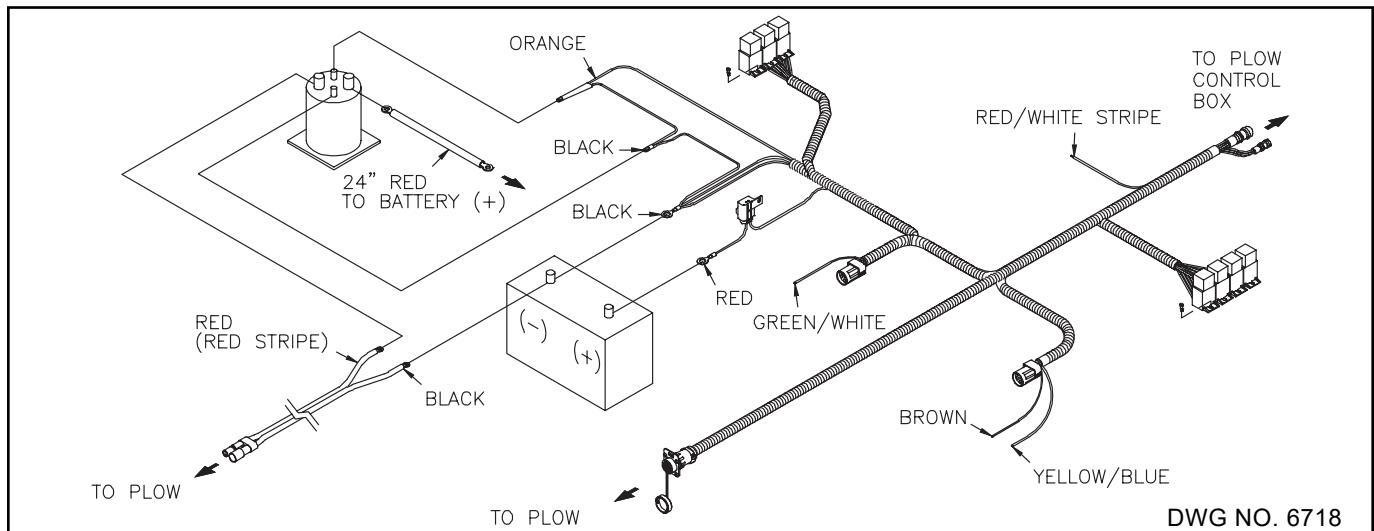

15. Select an area within 16 inches of the vehicle battery for the motor solenoid. Using the solenoid as a template, mark and drill two 3/16 inch diameter holes then fasten the solenoid with two 1/4" x 1/2" long self tapping screws from the hardware bag in the parts box. Connect the Black wire to one of the small posts on the solenoid, connect the Orange wire to the remaining small post, polarity is not important.

16. Safely route the 16-pin circular connector through the grill of the vehicle to a location that will be easily accessible with the plow attached.

17. Refer to drawing 6718. Install the underhood power cable by first connecting the Black cable and the three Black wires from the harness to the minus (-) post of the vehicle's battery. Connect the Red (or Red striped) cable to the motor solenoid. Route the power cable to the grill near the 16-pin connector.

Connect the red fused wire from the harness and the 24 inch Red cable to the plus (+) terminal of the battery or battery access post. Connect the other end of the 24 inch Red cable to the motor solenoid.

18. Locate three blue connector splices in the hardware bag in the plow's parts box.

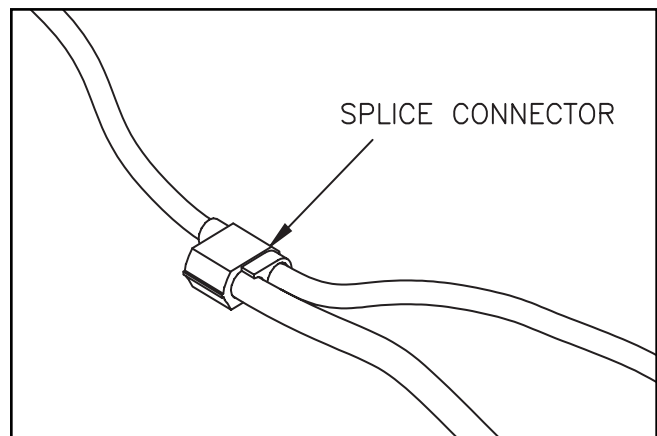

DWG NO. 4165

Using a blue splice, crimp the single brown wire from the underhood harness into the vehicle's driver's side parking light wire.

Using a blue splice, crimp the single yellow with blue stripe wire from the underhood harness into the vehicle's driver's side turn signal wire.

Using a blue splice, crimp the single green with white stripe wire from the underhood harness into the vehicle's curbside turn signal wire.

19. Select the proper headlight adapter for your vehicle, specific instructions are included with each kit.

The headlight adapter kit consists of two identical adapters. Install the adapters according to the instructions included with the kit and connect to the 5-pin connectors of the underhood wiring harness.



- Secure all cables away from hot or moving components with cable ties.

This completes the Electrical Installation.

- At this point, the mount kit should be assembled onto the truck.

Prongs from the truck mount kit should be at a height that will slightly lift the plow frame when attaching the plow. Prong receivers on the plow frame should be parallel to the ground when attaching the plow.

Apply powdered graphite on the truck prongs to help the plow to slide on and off more easily.

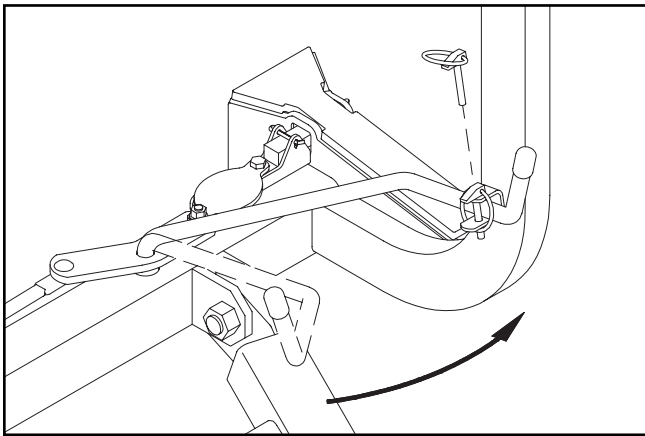

DWG NO. 6721A

Attach the plow onto the truck by driving the truck prongs into the receivers on the plow frame. Pull the latch handle into the frame clevis to move sliders through the notches in the prongs and receivers.

Pin the handle in the clevis with its klik pin.

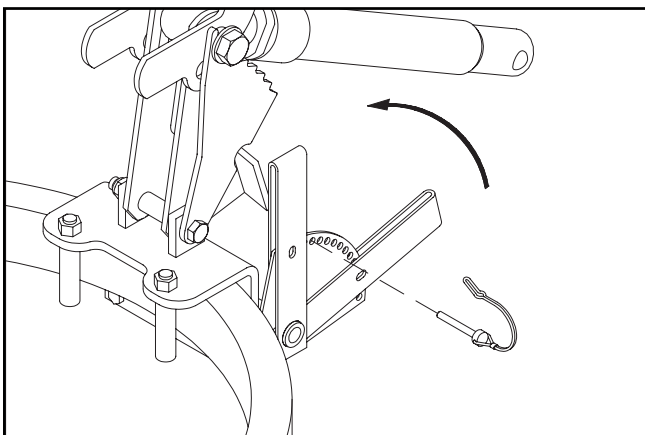

DWG NO. 5617A

Raise the parking stand to its highest position and repin.

Connect the two electrical cables from the plow to their corresponding receptacles on the truck.

- Select Hiniker Cold Flow Hydraulic Oil or an equivalent oil that meets military specification 5606, for plowing in extremely cold temperatures.

Pour hydraulic oil into the power unit oil reservoir until the oil level reaches the fill level.

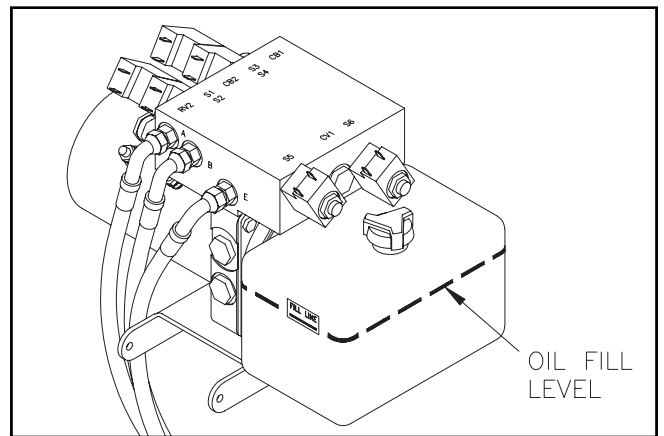

DWG NO. 6470

Before operating the plow for the first time, be sure to remove the two bolts on the back of the plow that prevent the moldboard from curling.

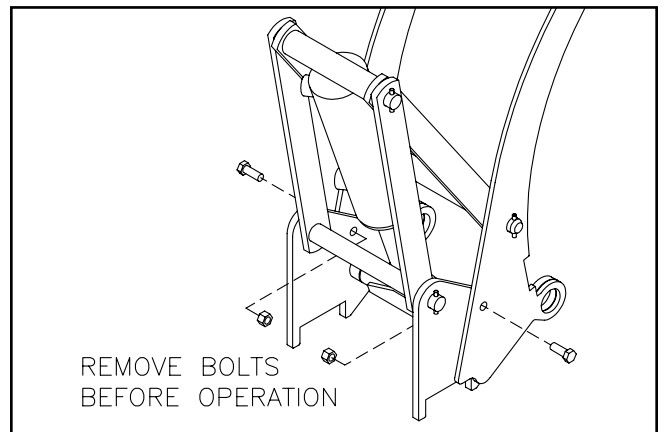

DWG NO. 5474

## 24 Plow Assembly

Raise and lower the plow, cycle the angling cylinders, and work the rollover function of the plow to purge any air trapped in the system.

Check the oil level with the plow on the ground and the blade uncurled. Add oil to the fill line, if necessary, but do not overfill the reservoir.

**NOTE:** New hydraulic lift and angle cylinders will leak a small amount of oil until packings become saturated and produce a good seal. If leakage is excessive, or if leaking continues after initial cycling, tighten the cylinder packing nut in 1/8-turn increments until leaking stops.

23. Fasten the power unit cover to the lift frame bracket with two 1/4" x 3/4" screws, flat washers and lock nuts from the hardware bag in the parts box. Tighten the lock nuts so that the assembly is secure, yet the cover hinges freely.

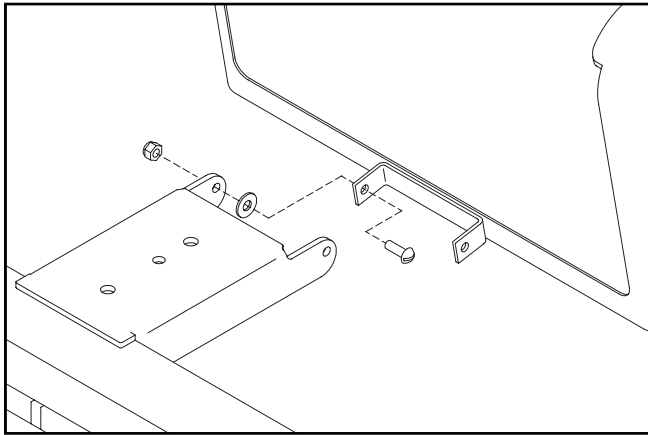

DWG NO. 6310

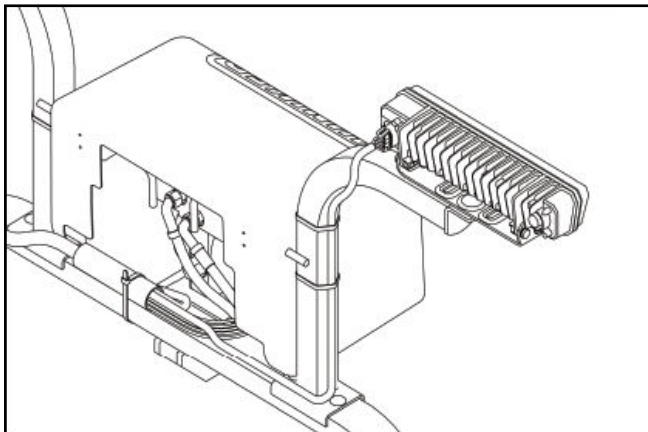

DWG NO. 6467B

When the cover is closed, rods from the latch handles should extend behind the light brackets to hold the cover in place.

24. Remove the 5/16" hex bolts and lock nuts holding the side markers to the top of the moldboard, and reassemble markers to the end of the moldboard.

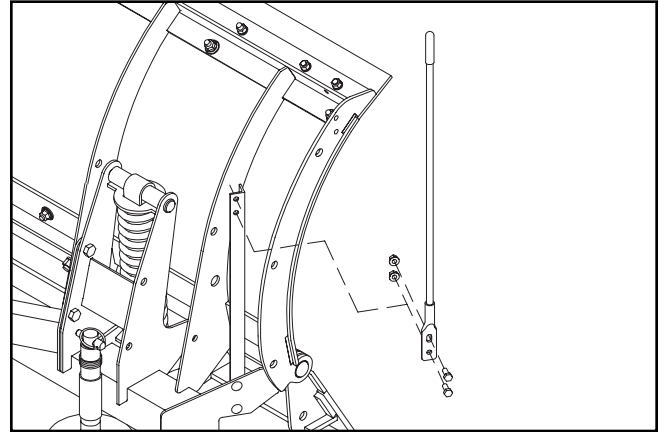

DWG NO. 5410

## SYSTEM CHECK-OUT

**NOTE:** The power cable and wiring harnesses must be connected between the snowplow and truck to test the functions of the headlights and power unit. Vehicle ignition must be switched on.

1. Move the headlight switch on the joystick controller to the "TRUCK" position and turn on the vehicle headlights. High and low beams should operate on the truck.
2. Move the switch to the "PLOW" position. Plow lights should operate in both high and low beams. Vehicle headlights should be off.
3. Test the parking lights and turn signals. Lights on the plow and truck should operate at the same time.
4. In an area clear of bystanders, test joystick functions by raising and lowering the plow, angling the plow side to side, and working the curl/uncurl mechanism.

Raise and lower functions may be reversed, as follows.

## JOYSTICK CONFIGURATION

As supplied from the factory, the snowplow controller raises the plow when the joystick is pulled backward and lowers the plow when the joystick is pushed forward.

These functions can be reversed by reassembling the joystick switch and face plate.

To reverse the face plate, pry the plate away from the controller by inserting a small screwdriver along the side of the plate at location 1 in drawing 5990. Flip the plate over, then reinstall by gently squeezing the long sides together and sliding the four tabs into slots in the controller top.

To reverse the joystick switch, remove four screws from the back of the controller and remove the main circuit board assembly from the case halves.

Gently pull on the edges of the small circuit board at the base of the joystick switch to remove the switch from the five pins on the main circuit board.

Rotate the switch 90°, then gently push the switch back onto the five pins.

Insert the main circuit board assembly back into the case top, making sure the joystick is properly seated and the harness strain relief is inside the case.

Reassemble the case with the four screws, checking that wires are not pinched between bosses.

Test the controller on the snowplow or a plow tester to verify that raise and lower functions match arrows on the face plate.

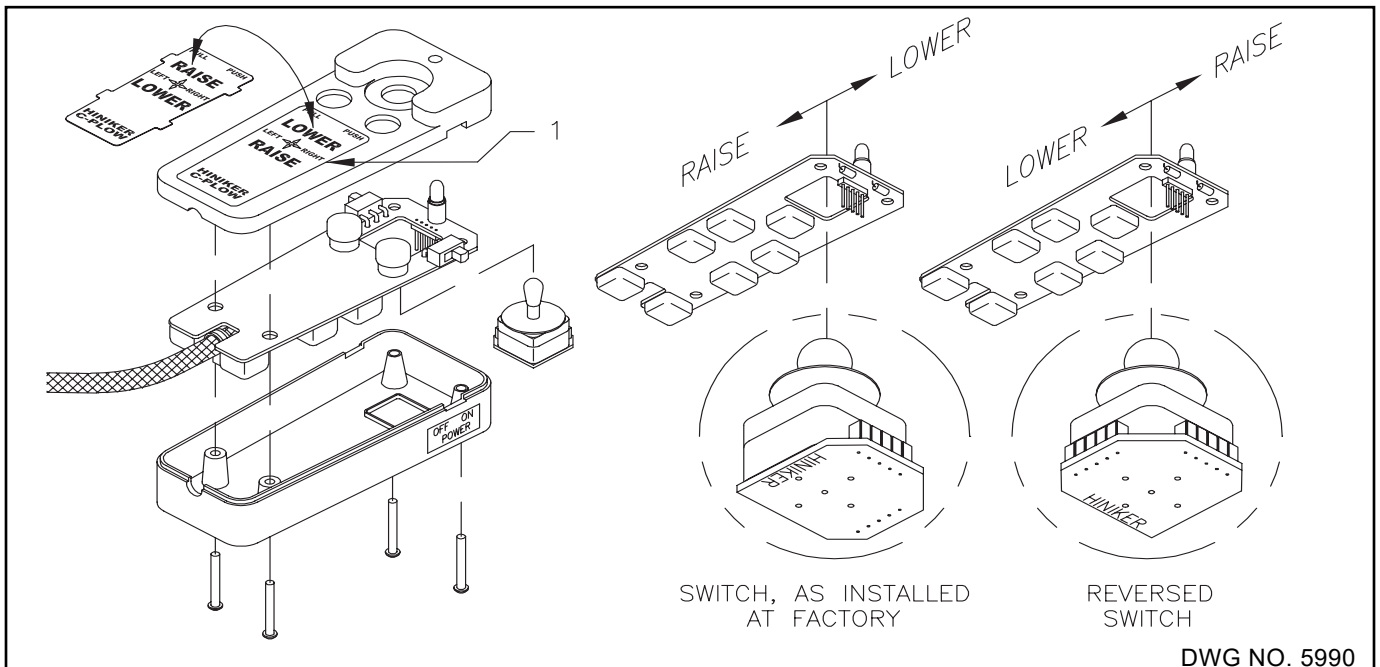

### HEADLAMP AIMING PROCEDURE

1. Park the vehicle with the plow attached on a level surface 25 ft (7.6 m) from a flat, unobstructed light-colored wall.

With no load on the vehicle other than the driver, snowplow and rear ballast weight, inspect the vehicle for proper tire inflation and broken or sagging suspension components. Check functioning of any automatic vehicle leveling systems and any specific manufacturer's instructions pertaining to vehicle preparation for headlamp aiming. Stabilize the suspension by rocking the vehicle side-ways.

2. Mark a vertical line (line 1) on the wall with black tape, or other means, directly ahead of the center of the vehicle.

Mark two additional vertical lines (lines 3 and 4) offset 20 1/2 inches (52 cm) from the first line representing the distance between the two plow headlamps.

3. Measure the height from the ground to the center of the plow headlamps, then mark a horizontal line (line 2) on the wall at that same height.

4. Refer to the following chart then mark a second horizontal line below the first (line 5), as required.

Headlamp Centerline Height	Vertical Aim Down
22 to 36 in (56 to 90 cm)	0
36 to 48 in (90 to 120 cm)	2 in (5 cm) Down
48 to 54 in (120 to 140 cm)	4 in (6.4 cm) Down

5. Wipe the lamp lenses clean and check for proper switching and function.

Activate the plow lamp HIGH beams to illuminate toward the wall. Focus the center of the LH light beam on the intersection of lines 3 and 5. Focus the center of the RH light beam on the intersection of lines 4 and 5.

Tighten the headlamp mounting hardware to 70 ft.-lbs. (95 N-m) maximum to hold the headlamps in position.

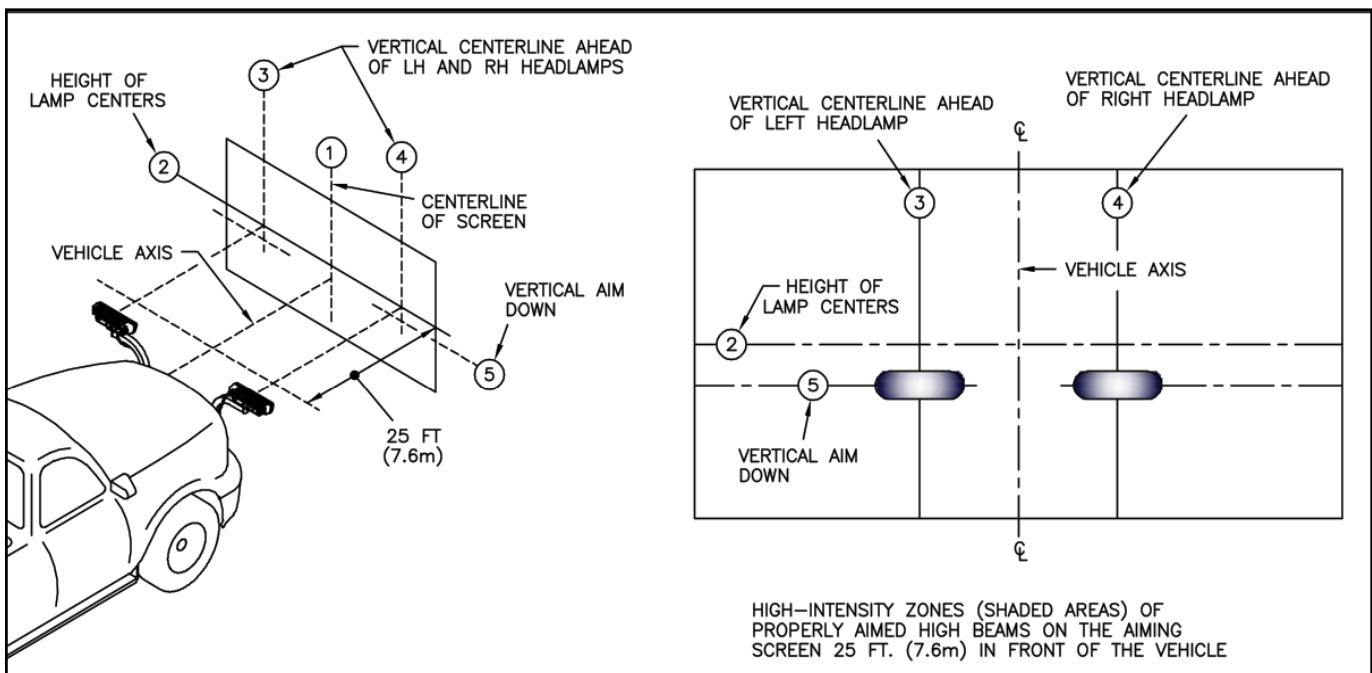

## SPECIFICATIONS

Blade Width	8'	9'
Plow Width at 31°	6'10"	7'8"
Blade Height	28"	
Lower Cutting Edge	3/8" X 6" 1084 steel	
Upper Cutting Edge	1/4" X 4" 1044 steel	
Weight	799 lbs.	848 lbs.
Recommended Hydraulic Fluid	Hiniker Cold Flow Mil Spec 5606 or Equivalent	
Hydraulic Fluid Capacity	3 qts.	
Motor Solenoid	12 VDC solenoid Continuous duty, sealed	
Wiring Harness Fuse	10 AMP	

# CAB CONTROL

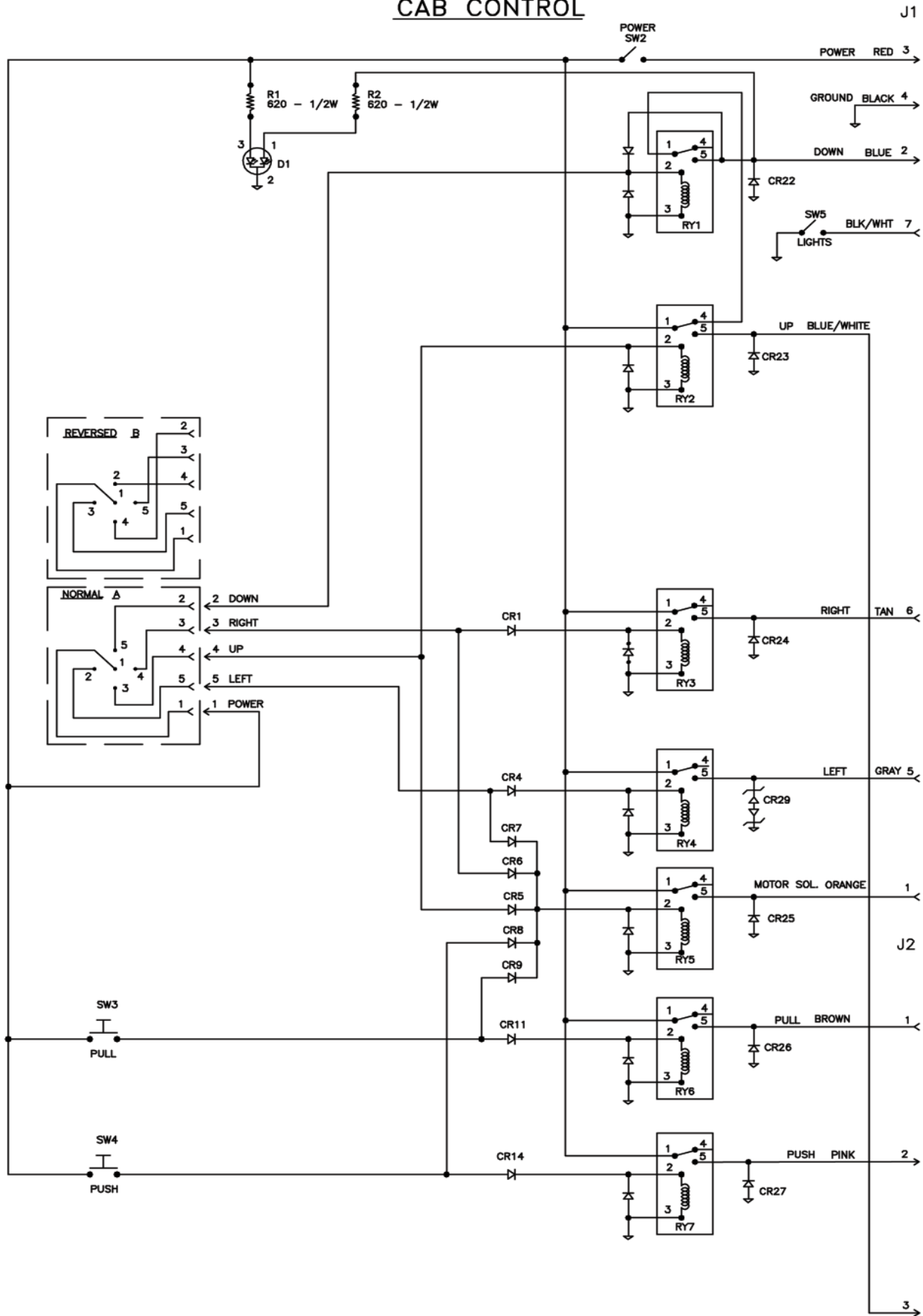

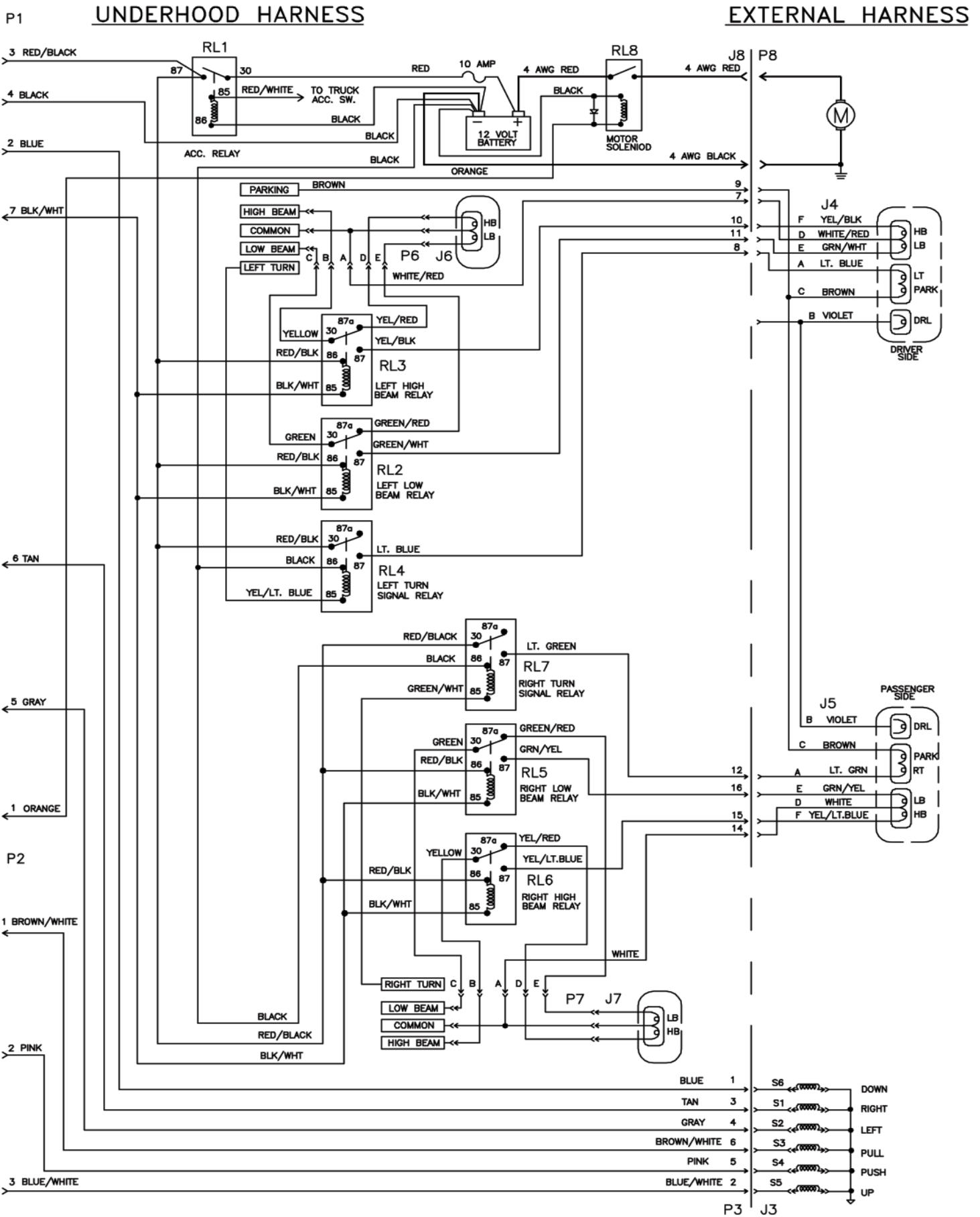

# C-PLOW POWER UNIT

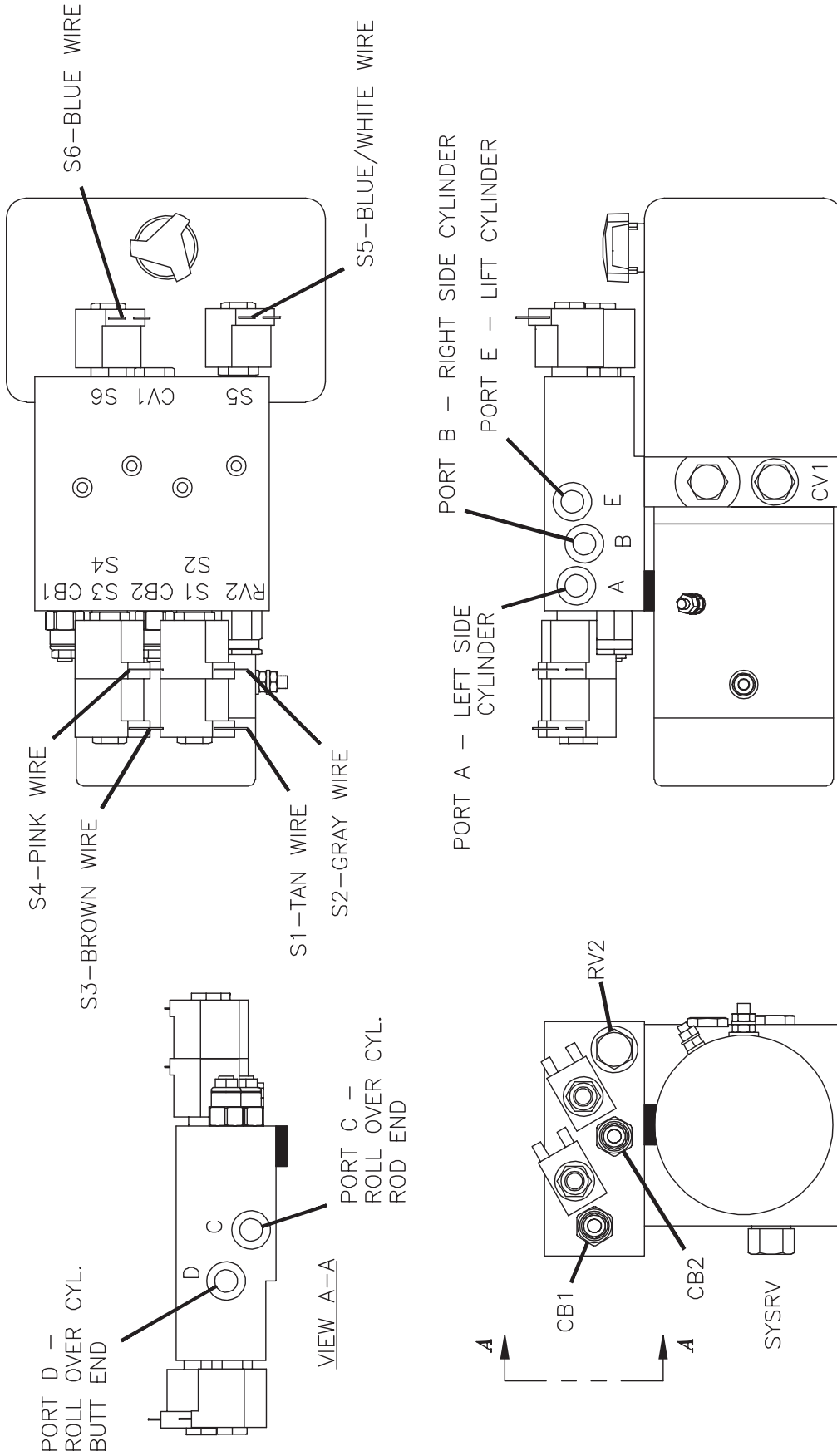

- SYSRV - RELIEF VALVE, SYSTEM, 2200 PSI
- RV2 - RELIEF VALVE, ANGLE CYLINDERS, 2800 PSI
- CB1 - VENTED COUNTER BALANCE VALVE, 2400 PSI
- CB2 - VENTED COUNTER BALANCE VALVE, 2400 PSI



# POWER UNIT HYDRAULIC CIRCUIT DIAGRAM

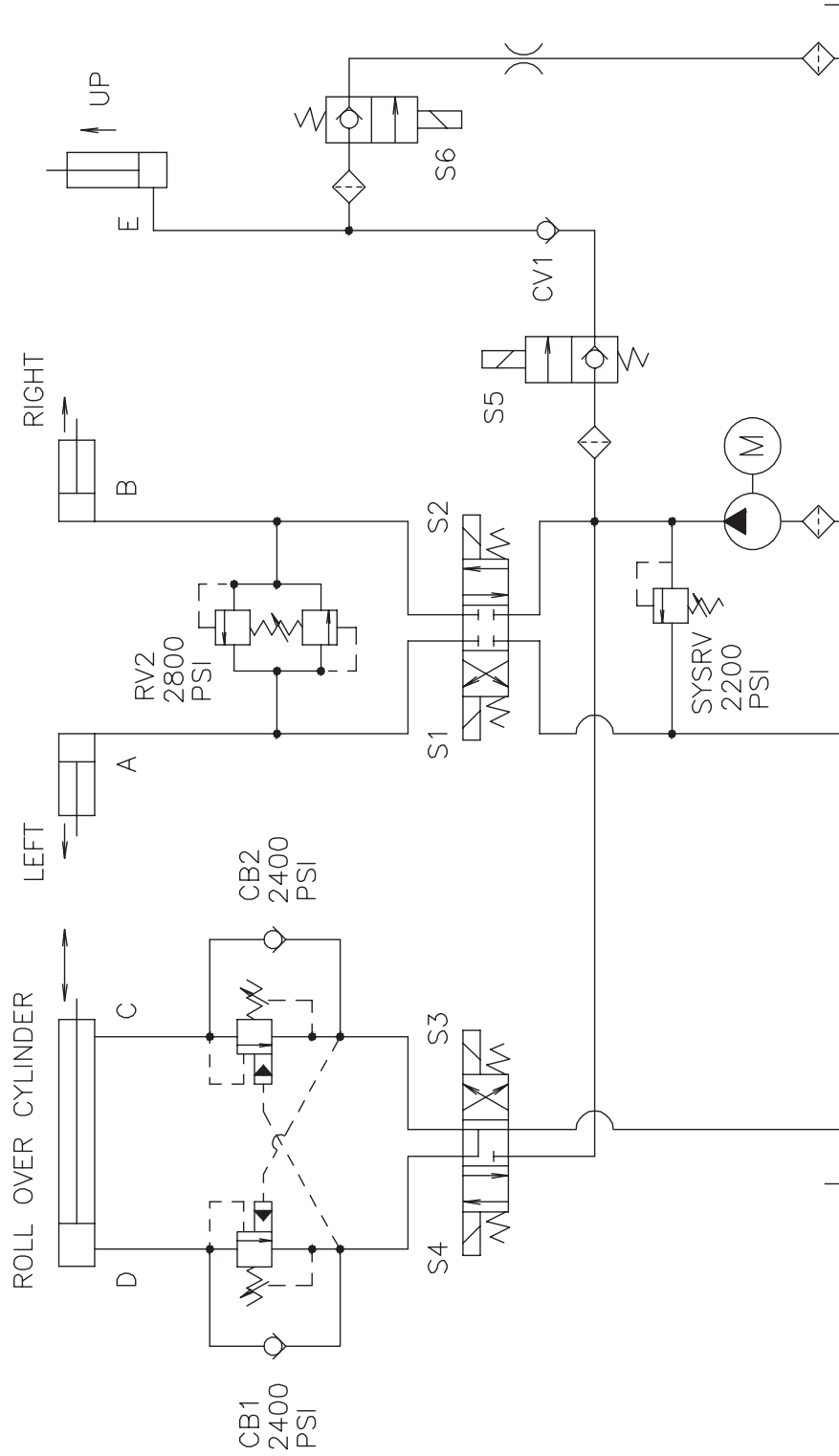

- S1 - LEFT EXTEND, RIGHT RETRACT - TAN WIRE
- S2 - RIGHT EXTEND, LEFT RETRACT - GRAY WIRE
- S3 - CURL - BROWN WIRE
- S4 - UNCURL - PINK WIRE
- S5 - LIFT - BLUE/WHITE WIRE
- S6 - LOWER - BLUE WIRE

# HINIKER WARRANTY

## HINIKER SNOWPLOW LIMITED WARRANTY

The only warranty Hiniker Company (Hiniker) gives and the only warranty that any Hiniker dealer is authorized to give on behalf of Hiniker is as follows: **(NO EMPLOYEE OR REPRESENTATIVE IS AUTHORIZED TO CHANGE THIS WARRANTY IN ANY WAY OR GRANT ANY OTHER WARRANTY.)**

Hiniker warrants to the original purchaser of a Hiniker snowplow that Hiniker will repair or replace any defects in material and workmanship that occur within two years from date of retail delivery except the following items: Hiniker warrants that it will repair or replace any defects in materials or workmanship with respect to the paint finish, any accessories, and service parts and components for a period of one year from date of retail delivery.

Hiniker's obligation and liability under this warranty is expressly limited to repairing or replacing, at Hiniker's option, at an authorized Hiniker dealer location, the defective parts at no charge to the original purchaser. **HINIKER MAKES NO OTHER WARRANTY, EXPRESS OR IMPLIED AND MAKES NO WARRANTY OF MERCHANTABILITY OR OF FITNESS FOR ANY PARTICULAR PURPOSE.**

**HINIKER'S OBLIGATION UNDER THIS WARRANTY SHALL NOT INCLUDE ANY TRANSPORTATION CHARGES TO OR FROM THE AUTHORIZED HINIKER DEALER LOCATION OR ANY LIABILITY FOR INCIDENTAL, INDIRECT OR CONSEQUENTIAL DAMAGE OR DAMAGES OF ANY KIND FOR LOST PROFITS OR DELAY.** If requested by Hiniker, products or parts for which a warranty claim is made are to be returned freight prepaid to our factory. Any improper use, operation beyond rated capacity, substitution of parts not approved by Hiniker Company, or any alteration or repair in such manner as in our judgment affects the product materially and adversely shall void this warranty.

Hiniker reserves the right to make improvements or changes to any of its products without notice. Such improvements or changes shall not trigger any obligation by Hiniker to update, modify or change any products previously sold by Hiniker.

HINIKER does not warrant the following:

1. Used products.
2. Any product that has been repaired, modified or altered in a way not approved by Hiniker Company.
3. Depreciation or damage caused by normal wear, lack of reasonable and proper maintenance, failure to follow Operators Manual Instructions, misuse, lack of proper protection during storage, or accident.
4. Parts replacement and service necessitated by normal wear or maintenance including, but not limited to, cutting edges, hoses, snowplow skid shoes, blade marker guides and hardware.
5. Paint finish damage caused by normal wear.

Hiniker does not assume any liability for any damage to a motor vehicle resulting from the attachment or use of a Hiniker snowplow. Compliance with applicable motor vehicle regulations is the responsibility of the installer. Attachment of a Hiniker snowplow to a motor vehicle is at the risk of the purchaser.

It is the responsibility of the original snowplow purchaser to verify the original date of purchase.

A DELIVERY REPORT FORM must be filled out and received by Hiniker with 30 days of retail delivery at the address below to initiate the warranty coverage.

**HINIKER COMPANY**  
58766 240th St.  
MANKATO, MN 56001  
PHONE (507) 625-6621 -- FAX (507) 625-5883  
[www.hiniker.com](http://www.hiniker.com)

