



PICKUP TRUCK SNOWPLOW

Models 1700SS, 1750SS

OPERATOR'S MANUAL

**DO NOT USE OR OPERATE THIS EQUIPMENT UNTIL THIS MANUAL
HAS BEEN READ AND THOROUGHLY UNDERSTOOD**

PART NUMBER 25013776 Rev. B

TABLE OF CONTENTS

25013776 Rev. B

5/18

Hiniker/25013776RevB

TO THE PURCHASER.....	2
SAFETY.....	3
OPERATING PROCEDURES.....	4
TROUBLE SHOOTING.....	9
MAINTENANCE.....	11
ASSEMBLY.....	13
SYSTEM CHECKOUT AND JOYSTICK CONFIGURATION.....	22
SPECIFICATIONS.....	23
ELECTRICAL CIRCUIT.....	24-25
HYDRAULIC CIRCUIT.....	26-27
WARRANTY.....	28

TO THE PURCHASER

This product is designed and manufactured to give years of dependable service when properly maintained and used for the purpose for which it is intended. Never allow anyone to operate this equipment until they fully understand the complete contents of this manual. It is the responsibility of owners who do not operate this equipment to ensure the operator is properly instructed and understands the contents of this manual. It is also the owner's responsibility to ensure that anyone operating this equipment is mentally and physically capable of so doing.

Important information is contained in this manual to help ensure safe and efficient operation.

If you have any questions about this manual, or the equipment discussed herein, contact your Hiniker dealer.

 **TAKE NOTE! THIS SAFETY ALERT SYMBOL FOUND THROUGHOUT THIS MANUAL IS USED TO CALL YOUR ATTENTION TO INSTRUCTIONS INVOLVING YOUR PERSONAL SAFETY AND THE SAFETY OF OTHERS. FAILURE TO FOLLOW THESE INSTRUCTIONS CAN RESULT IN INJURY OR DEATH.**

 **THIS SYMBOL MEANS:**
- ATTENTION!
- BECOME ALERT!
- YOUR SAFETY IS INVOLVED!

 **SAFETY SIGNAL WORDS:**

DANGER: Indicates an imminently hazardous situation that, if not avoided, will result in death or serious injury.

WARNING: Indicates a potentially hazardous situation that, if not avoided, could result in death or serious injury.

CAUTION: Indicates a potentially hazardous situation that, if not avoided, may result in minor or moderate injury, or damage to components.

NOTE: Addresses safety practices not related to personal safety.

All references to Left or Right are defined as viewing the plow from the cab of the truck.

Instructions for raising and lowering the plow refer to the joystick controller as received from the factory. The raise and lower functions may be reversed to suit the preference of the operator by following the instructions on page 22 for switching the controller joystick and face plate.

This Operator's Manual is shipped with this equipment. Contact your Hiniker dealer for additional copies.

Always obtain original Hiniker service parts. Substitute parts could adversely affect equipment performance and warranty.

Check that your dealer has forwarded the Hiniker delivery report form along with the plow identification number because it helps maintain maximum service and warranty benefits. This does not put you on any mailing list, and information thereon is not available to others.

Your plow's identification number plate is at location (1) in the following illustration.

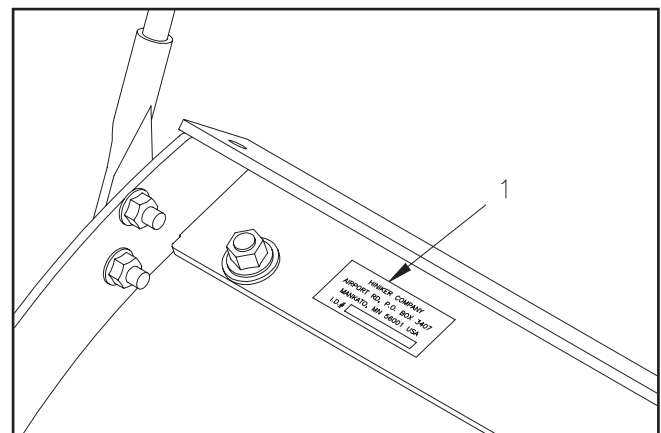

DWG NO. 5689

Record the following information for later reference when obtaining service parts:

Purchase Date _____

Purchaser's Name _____

Dealer's Name _____

Machine I.D. No. _____

SAFETY



This is a safety alert symbol. It alerts an operator to information concerning personal safety. Always observe and heed these symbols and instructions, otherwise death or serious injury can result.

Operator safety is a principle concern in equipment design and distribution. However, many accidents occur because a few seconds of thought, and a more careful approach to handling, were ignored.

Accidents can be avoided by knowing and following the precautions cited in this manual.

GENERAL SAFETY

1. Read this manual thoroughly. Make sure the operator understands it and knows how to operate this equipment safely. This equipment can kill or injure an untrained or careless operator and bystanders. If you sell this equipment, ensure the new owner acknowledges receipt of this manual.
2. This plow is intended for plowing snow only. Plowing gravel, rocks, etc., or using the plow for any purpose other than plowing snow could result in harm to the operator or bystanders or cause damage to the plow or vehicle, and will void the warranty.
3. Do not service or otherwise handle a plow in the raised position unless it is securely blocked against unexpected falling.
4. Do not attempt to handle or service this equipment, or direct others to do the same, unless you know how to do it safely and have the proper tools for the job.
5. Keep hands, feet, hair, and clothing away from moving parts.
6. Do not alter the equipment to the extent of compromising safety or performance.

BEFORE OPERATION

1. Discipline yourself to visually check for worn, damaged or cracked parts before starting use. Replace these with genuine Hiniker parts.
2. Escaping hydraulic oil under pressure can penetrate the skin, causing serious injury. Do not use your hand to check for leaks. Use a piece of paper or cardboard to find suspected leaks. Tighten all connections before pressurizing hydraulic lines.

If fluid is injected into the skin, get medical attention immediately to prevent serious infection.

3. Check all controls and operating functions of the machine in a safe area before starting to work.

DURING OPERATION

1. Always wear seat belts when operating a motor vehicle.
2. Ensure everyone is clear of the machine, especially away from blind areas of the operator, before starting, actuating hydraulics or operating this equipment.
3. Do not plow snow at excessively high speeds.
4. Avoid hitting objects that will damage your plow or truck.
5. Set the brakes and stop the truck's engine before adjusting or servicing your plow.

AFTER OPERATION

1. Park the plow on a solid, level surface. Lower the plow to the ground so that the lift cylinder is fully retracted, then pin the lift links, as described in "Removing The Plow" on pages 7 and 8 before unhitching the plow frame to prevent the plow from tipping forward.

OPERATING PROCEDURES

ATTACHING THE PLOW

Attachment prongs on the truck should be mounted such that the bottom edge of the prongs measure about 10 inches above the ground. Prong receivers on the plow frame should remain parallel to the ground and at the correct height by fully retracting the lift cylinder when lowering the plow, then bracing the frame by pinning the lower lift link before removing the plow from the truck (See "Removing The Plow"). Ideally, the prongs on the truck should lift the plow frame slightly when driving into the plow for attachment.

Powdered graphite applied on the prongs will help the plow slide on and off more easily.

Check that prongs are in line with the receivers before slowly driving into the plow. Set the parking brake in the truck to prevent it from creeping back out from the receivers.

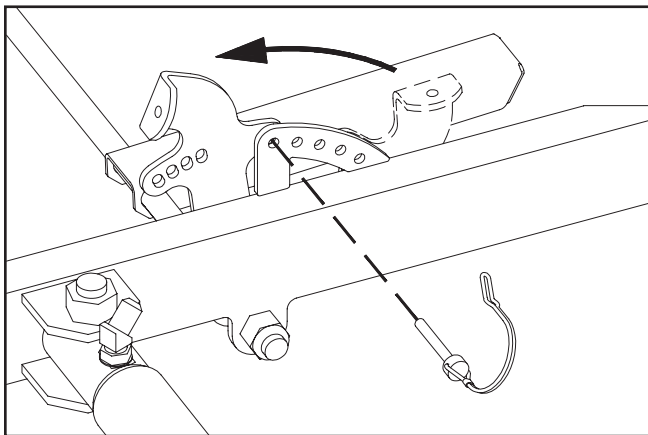

DWG NO. 7463

Remove the tab lock pin from the indexing hole and raise the parking stand to its highest position. Repin the stand lever to the front hole in the push frame for transport.

Pull the latch handle into the clevis on the lift frame to force the sliders through the notches in the prongs and receivers. Check that both sliders are fully engaged.

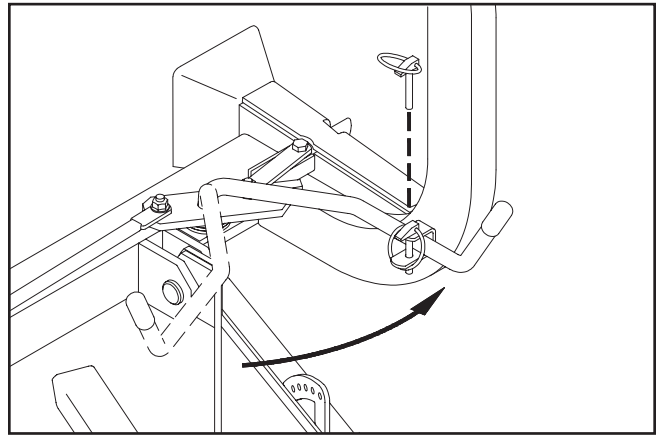

Handle Pinned With Plow On Truck DWG NO. 5691

Pin the handle in the clevis with its klik pin. Failure to pin the handle in place may allow the plow to fall off the truck.

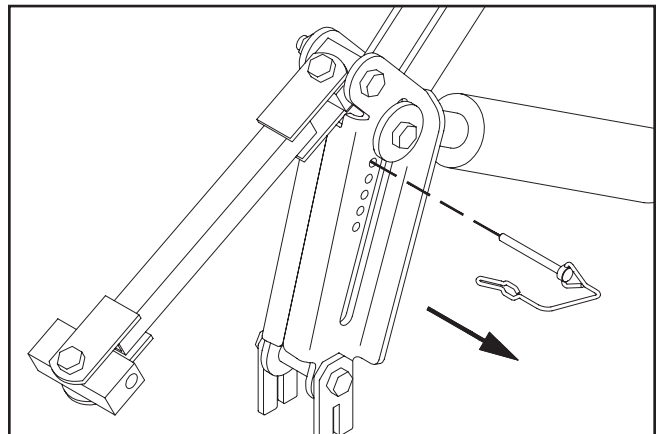

DWG NO. 7464A

Remove the tab lock pin from the lift linkage and store it in the park stand lever.

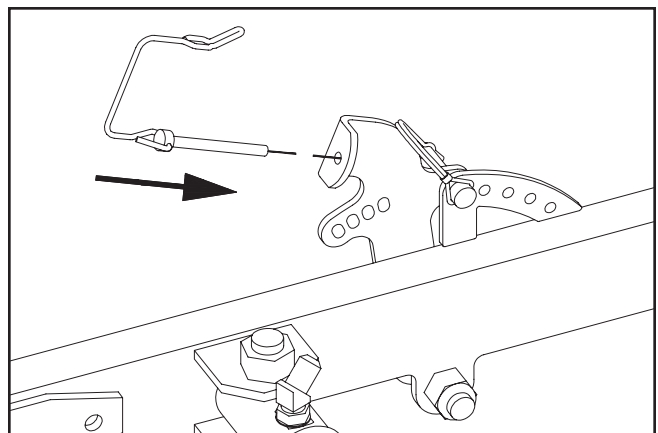

DWG NO. 7465A

NOTE: Before connecting the plow's wiring to the truck, make sure power is switched "Off" on the joystick controller.

Plug in the two electrical connectors between the plow and the truck after latching the plow.

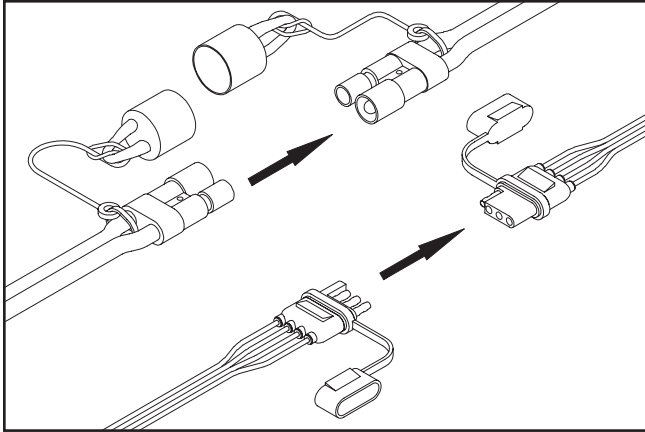

DWG NO. 7492

Test the lift and angling functions in a safe area before using the plow.

The indicator rod at the back of the plow frame raises and lowers with the moldboard to show the plow position.

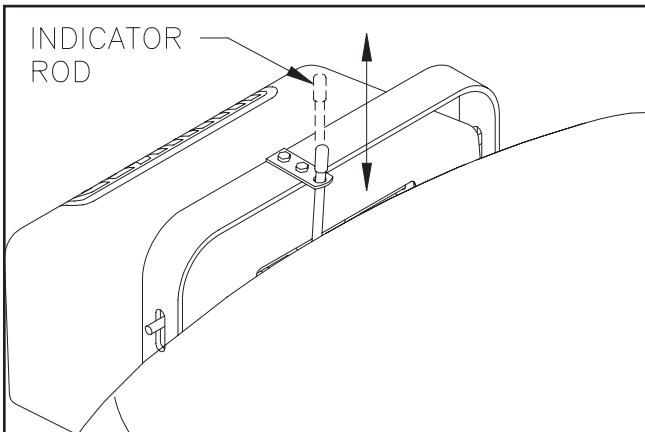

DWG NO. 7466

To make alignment with the plow easier in the future, mark a point on the hood near the front of the truck and a point on the windshield that are in line with the cap on the plow's indicator rod when you are seated behind the steering wheel. Line up these three points when driving into the plow.

THE JOYSTICK CONTROLLER

The joystick control box has slide a switch on the side for controlling power to the snowplow.

The joystick controller raises and lowers the plow and angles the blade left or right.

NOTE: Drawings 7467 and 7468 show the raise and lower functions of the joystick controller as received from the factory. Functions may be reversed to suit the preference of the operator by following the instructions on page 22 for switching the controller joystick and face plate.

The vehicle's electrical power must be turned on before the control box will function.

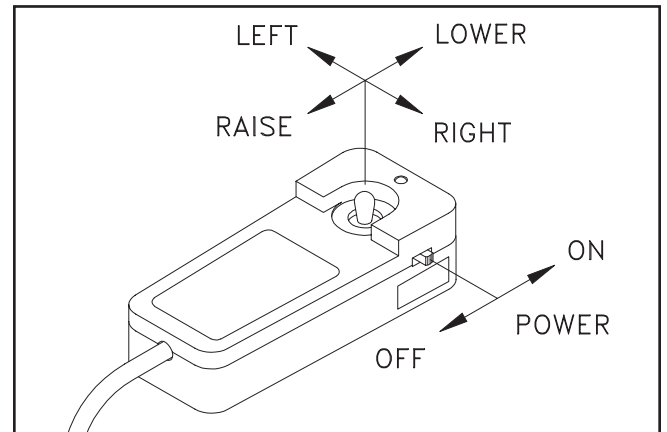

Joystick Control Box

DWG NO. 7467

Place the on/off switch on the joystick control box in the "on" position to supply power to the snowplow. A green light will indicate power is on.

Raise or lower the plow by moving the joystick to the "raise" or "lower" position.

Hold the plow at an intermediate height by releasing the controller from the "raise" position when the plow reaches the desired height.

When lowering the plow, continue holding the joystick for a moment after the blade first touches the ground to allow the cutting edge to reach the proper plowing angle.

Move the joystick left or right to angle the blade. Release the joystick when the blade is at the desired angle.

TRANSPORTING THE PLOW

The extra weight of the snowplow on your truck will impair handling response and increase braking distance. The plow will also block some airflow to the vehicle's cooling system, possibly causing the vehicle to overheat. Therefore, it is important not to exceed speeds above 45 mph when the plow is attached.

Remove the plow if you must drive your truck for long distances when the temperature is warm.

Fully raise the plow for maximum ground clearance before driving.

Transport the plow with power to the joystick control box switched off to prevent accidental lowering of the plow.

Never adjust the blade height or angle the blade while driving.

PLOWING SNOW



WARNING: Always wear a seat belt when plowing snow. Sudden contact with a hidden object can result in serious personal injury.

Inspect areas to be plowed before snowfall for potential hazards, and mark obstructions with stakes that will be seen when snow covers the ground. Identify any emergency equipment and utility outlets that may need to be cleared in the event of a storm. Prepare a plan beforehand for clearing snow from tight or enclosed areas and locate sites for stacking snow.

When using skid shoes on the back of the moldboard, adjust the skids according to the surface to be plowed. The bottom of the skids should be about 1/2" below the cutting edge when plowing gravel roads or lots. Skids should be even with the cutting edge on hard surfaces such as asphalt or concrete.

Always plow snow as it is accumulating. Wet snow may weigh about 12 pounds per cubic foot. The weight of snow being pushed by your plow may increase to several tons.

Allowing snow depth to grow to unmanageable levels can cause difficult removal problems and can be costly in terms of wear on equipment.



WARNING: Serious personal injury can result from plowing at excessive speeds, as well as costly damage to equipment and property, if an obstruction is encountered while plowing. Do not exceed 10 mph while plowing.

Plow snow in the lowest truck gear to transfer maximum power to the cutting edge. Clear areas in front of buildings first. Back drag snow away from buildings by driving to the building with the plow raised, then dropping the blade to pull snow away from buildings.

Clear large lots by angling the blade and creating a single path. Roll snow to outer edges of the lot by taking successive passes with the blade angled.

When plowing very deep snow, it may be necessary to raise the blade and shear off layers of snow until a working area is cleared. Work small areas in multiple passes to push snow to outer edges. Generally, 6 inch snow can be plowed with the entire blade width; 9 inch snow with 3/4 of the blade width; 12 inch snow with 1/2 of the blade width. Local conditions will determine how much work can be done before stalling or getting stuck.

PARKING

Lower the plow to the ground when parking your truck for a long period of time with the plow attached. Place the on/off switch in the "off" position to prevent the plow from drawing power from the truck battery. The plow's power unit may continue to draw electrical current from the truck battery if the control switch is left on; possibly resulting in insufficient charge to start the truck.

REMOVING THE PLOW

To remove the snowplow from your truck, park on a solid level surface with the blade straight across the truck. Lower the plow to the ground and continue holding the joystick for a moment to allow the hydraulic cylinder to fully retract.

Switch power off on the controller.

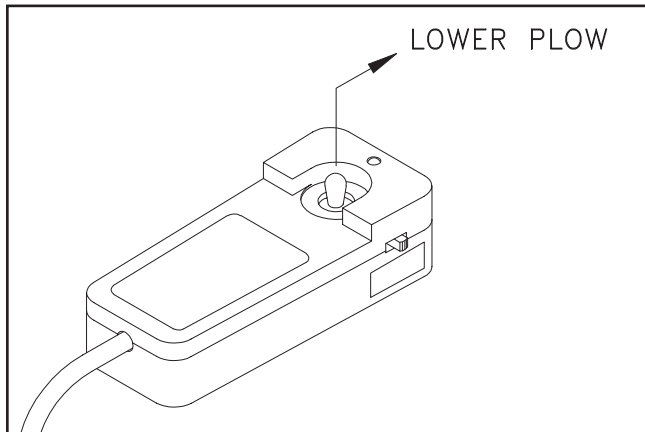

DWG NO. 7468

Retracting the lift cylinder will orient the prong receivers correctly for reattaching the plow later. Failure to retract the lift cylinder rod will allow the lift frame to fall forward, possibly causing personal injury or damage to plow components.

At the front of the truck, remove the tab lock pin from it's transport location on the plow push frame, then gently push back on the receiver frame to remove slack from the lift links and to level the prong receivers.

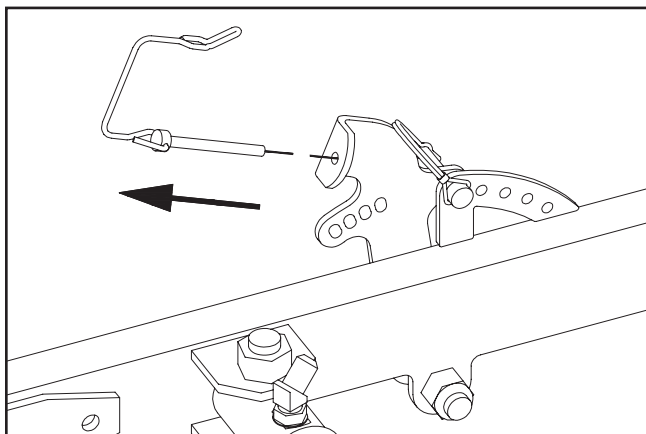

DWG NO. 7469A

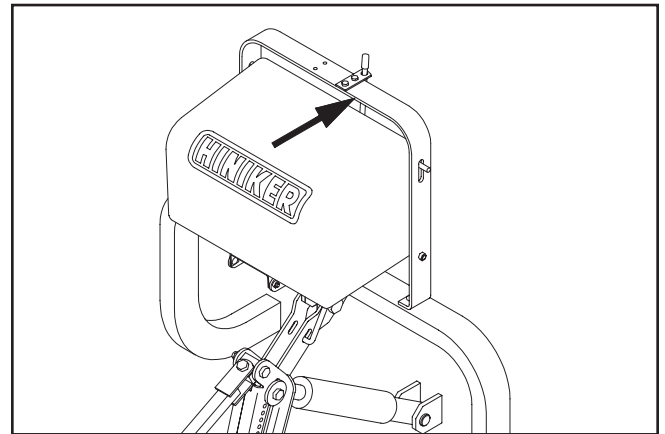

Remove Slack From Links

DWG NO. 7470A

Install the pin through the hole in the LH lower lift link directly below the thick washer to brace the plow frame.

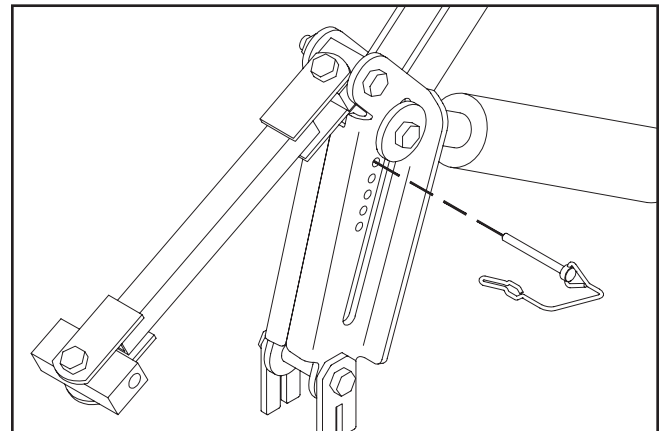

Pin Through Lift Link

DWG NO. 7471A

Swing the latch handle open until the sliders are fully removed from the attachment prongs.

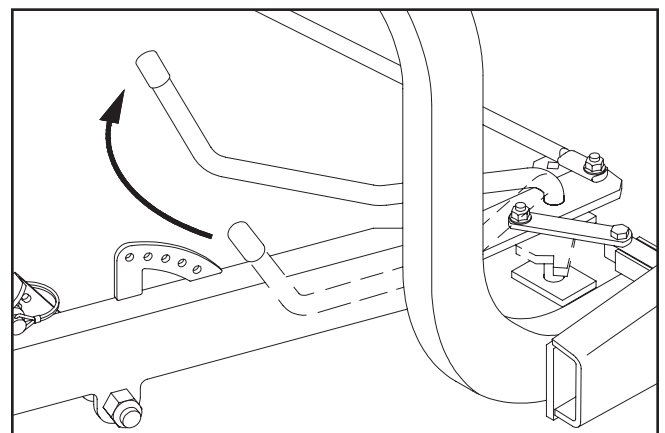

Swing Handle to Remove Sliders

DWG NO. 5694

8 Operating Procedures

Lower the parking stand to the ground by removing the tab lock pin from the front hole in the push frame, then swinging the stand to the ground with the lever.

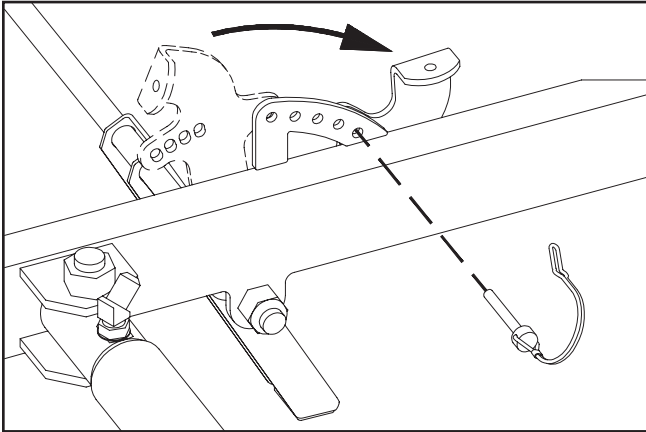

Lower and Pin Parking Stand

DWG NO. 7472

Reinstall the pin through matching holes in the stand lever and push frame to hold the stand in place.

Disconnect the two electrical connectors by pulling them straight out from the receptacles. Do not twist the connectors. Twisting will damage the connector pins or the wiring harness.

Place dust caps on connectors to prevent contamination.

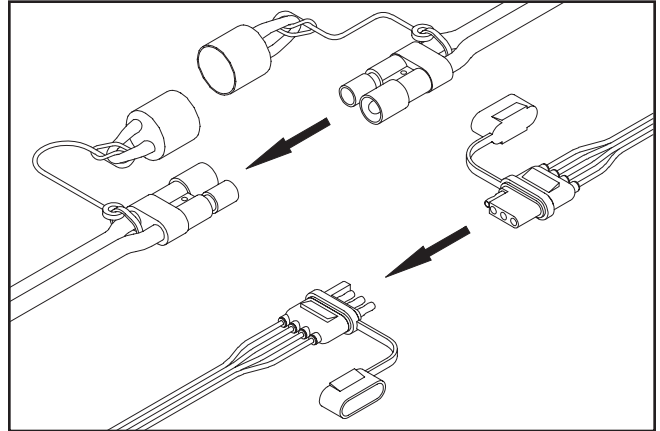

Disconnect Plugs

DWG NO. 7491

Return to the truck cab and slowly drive straight back from the plow.

If the snowplow won't be used for an extended period of time, the prong weldment can be removed from the truck by removing the hex bolts that fasten it to the truck mount frame.

TROUBLE SHOOTING

GENERAL

1. Check to see that the motor is wired correctly with tight connections, for the proper voltage.
2. Check reservoir oil level.
3. Check that wiring harness relay connections are wired correctly
4. Check for external leakage at cylinders, hoses and power unit.

PROBLEM	POSSIBLE CAUSE	REMEDY
1. Plow does not attach to vehicle	A. Receivers are tipped forward B. Prongs recoil out of receivers when attaching C. Park stand pinned too low	A. Fully retract lift cylinder and pin lift linkage to brace lift frame before removing plow from truck. B. Slowly drive into receivers and set parking brake C. Lower receivers by adjusting park stand.
2. Pump motor does not run	A. Defective solenoid B. Defective pump motor C. Weak or defective battery D. Bad electrical connections E. Defective joystick control box F. Blown fuse supplying power to control box	A. Replace solenoid B. Replace brushes or motor C. Charge or replace battery D. Clean and tighten connections E. Replace control box F. Replace fuse
3. Pump runs with joystick in neutral	A. Defective solenoid B. Defective joystick control box C. Wiring short	A. Replace solenoid B. Replace control box C. Locate and repair
4. Plow will not lower	A. Reversed wiring on valve block B. Defective joystick control box C. Defective lift return valve or coil	A. Correct wiring B. Replace control box C. Replace valve or coil
5. Hydraulic cylinder does not function or functions slowly, motor runs	A. Weak or defective truck battery B. Oil level low C. Hydraulic connection leak D. Solenoid valve not opening properly	A. Charge or replace battery B. Add oil (do not overfill) C. Tighten or redo connection D. Replace valve
6. Plow does not remain raised with joystick in "neutral" position	A. Leakage through pump check valve B. Internal leakage in cylinder C. Defective joystick control box.	A. Clean valve, or replace B. Repack or replace cylinder C. Replace control Box

PROBLEM	POSSIBLE CAUSE	REMEDY
7. Angling cylinders relieve too easily or too difficultly while plowing	A. Relief pressure set too low or too high	A. Have relief pressure adjusted by Hiniker snowplow dealer
8. Oil leaks from angling cylinder(s)	A. Loose packing B. Defective cylinder	A. Tighten packing 1/8 turn B. Repack or replace cylinder
9. Battery goes dead with power to the control box on and joystick in neutral position.	A. Short in wiring B. Defective joystick control box	A. Locate and repair B. Replace control box
10. Battery goes dead with power to the control box off.	A. Short in wiring	A. Locate and repair
11. In extremely cold temperatures, the oil in the hydraulic system is thickened, causing slow functioning of the plow	A. Cold temperatures	A. As the system warms, the oil will thin out and function normally. B. Select Hiniker Cold Flow Hydraulic Oil for plowing in extremely cold temperatures.
12. Pump chatters when raising plow	A. Hydraulic oil low	A. Add hydraulic oil until chattering stops. Do not overfill.
13. Oil running out of cap on hydraulic reservoir	A. Plowing on steeply inclined terrain B. Too much oil	A. Avoid excessive inclines or change direction of plowing B. Remove excess oil
14. Vehicle overheats with the plow on	A. Vehicle coolant level low B. Ice and snow buildup in grill C. Insufficient airflow to engine compartment	A. Add coolant B. Remove ice and snow C. Transport plow at lower speeds

MAINTENANCE



WARNING: Do not service or otherwise handle a plow in the raised position unless it is securely blocked against unexpected falling.

Dependable snowplow operation is the result of following good maintenance procedures. Inspect your plow frequently to ensure that all parts are working smoothly, and develop a schedule for maintenance at required intervals.

GENERAL

Wash salt and dirt off the plow before storage. Do not power wash hydraulic cylinders, as high pressure can damage seals and cause cylinder failure. Touch-up any chips or scratches in the paint and apply a light coating of grease to extended cylinder rods to prevent corrosion.

HYDRAULIC SYSTEM

The majority of snowplow operational problems are caused by bad oil in the hydraulic system. Hydraulic oil should be changed every year for best performance. Select Hiniker Cold Flow Hydraulic Oil, or an equivalent oil that meets military specification 5606, for plowing in extremely cold temperatures.

To change hydraulic oil, disconnect the electrical wiring harnesses from the snowplow power unit and uncouple four hydraulic lines. Unbolt the power unit from the plow, and remove it to a clean working area that can capture any spilled oil.

Carefully unbolt the oil reservoir from the power unit and discard old oil. Purge old oil from the angling cylinders by forcing rods to retract.

Clean the suction filter at the pump inlet and wipe any metal shavings off the magnet on the pump.

Re-attach the reservoir onto the power unit and re-connect the power unit on the snowplow before adding new hydraulic oil.

Re-attach hydraulic hoses and electrical wires at the correct locations on the power unit.

Pour hydraulic oil into the power unit reservoir until the reservoir is half full. Angle the plow full left or right to fill the angling cylinder with oil, then add more oil until the reservoir is about 3/4 full. Do not overfill the oil reservoir.

Cycle the plow left and right and up and down to purge any air trapped in the hydraulic system.

Check the oil level with the plow on the ground. Add oil to the fill line, if necessary, but do not over fill the reservoir.

ELECTRICAL MAINTENANCE

Periodically check all electrical connections for proper fit and remove any contamination that may be present.

To prevent contamination always place dust caps on connectors when not in use. This is particularly important when the plow is being stored. The use of dielectric grease is recommended to reduce corrosion of the contacts and to make connecting and disconnecting easier.

Before each season check the vehicle battery and electrical system for proper operation. A weak battery, dirty terminals, or faulty charging system may cause improper operation and possible failure of the joystick controller.

MECHANICAL COMPONENTS

Prior to the operation of a new snowplow, or one which has been stored, inspect all hardware and verify proper torque on all bolts and nuts in accordance with the recommended torque specifications.

Two 1/2 inch hex bolts in the trunnion on the back of the moldboard are also factory retained with anaerobic threadlock. Apply a commercially available threadlock to standard 1/2-13 x 1" grade 5 hex bolts if replacement is necessary.

GRADE 5 TYPE B & F LOCK NUT TORQUE VALUES

Size	Ft-lbs.	N-m
5/16"	13-18	17-25
3/8"	23-33	31-44
1/2"	58-82	79-112
5/8"	117-165	158-223

GRADE 5 BOLT TORQUE VALUES*

Size	Ft-lbs.	N-m
1/4"	8-12	11-16
3/8"	29-41	39-56
1/2"	73-103	99-140
5/8"	146-206	198-279

*applications without lock nuts.

Loose bolts can cause hole elongation and part failure resulting in dangerous operating conditions and equipment breakdown.

Check all hardware periodically during operation and keep tightened to specified torque value.

Replace worn bolts and lock nuts with grade 5 bolts and equivalent type B or type F lock nuts. Type B lock nuts are plain hex; type F lock nuts are flanged hex.

Inspect wear of the cutting edge before every plowing season and frequently throughout the season. Replace the cutting edge before wear reaches the main plow blade.

The 5/16" hex bolts in the latch sliders are factory retained with anaerobic threadlock. If removal or replacement of these bolts is necessary, purchase new bolts with threadlocker from your Hiniker dealer, or apply a commercially available threadlock, i.e., Loctite 242 (blue) or Perma-Lok HM118 (red), to standard 5/16-18 X 3/4" grade 5 hex bolts before reassembly.

PLOW ASSEMBLY

GENERAL INFORMATION



WARNING: To prevent personal injury or death, be certain to keep clear of any parts that may drop when removing bundling straps, wires or brackets. Support heavy sections with hoist or blocks before removing wires or straps.

In the following instructions, left and right machine references are defined as being viewed from the cab of the truck. Be certain that hydraulic hoses and electrical wires are safely routed and allow full motion of moving parts. Secure loose wires with plastic tie straps. Some components are fastened at incorrect locations for shipping purposes.

All hardware should be tightened only enough to ensure safety during assembly. Torque hardware to specified values, as shown in the following chart, only after assembly has been completed.

GRADE 5 TYPE B & F LOCK NUT TORQUE VALUES

Size	Ft-lbs.	N-m
5/16"	13-18	17-25
3/8"	23-33	31-44
1/2"	58-82	79-112
5/8"	117-165	158-223

GRADE 5 BOLT TORQUE VALUES*

Size	Ft-lbs.	N-m
1/4"	8-12	11-16
3/8"	29-41	39-56
1/2"	73-103	99-140
5/8"	146-206	198-279

* applications without lock nuts

Replace worn bolts and lock nuts with grade 5 bolts and equivalent type B and type F lock nuts. Type B lock nuts are plain hex; type F lock nuts are flanged hex.

PLOW ASSEMBLY

1. Place moldboard face down on cardboard or other padding that will prevent scratches in the paint.

Remove two side markers and four shipping brackets from the ends of the moldboard. Save the bolts and nuts for reinstalling markers later.

Remove 3/4 inch x 3 1/4 inch hex bolts and lock nuts from two clevises on the back of the moldboard and save for attaching hydraulic cylinder rods. Unbolt the 1/2 inch x 4 3/4 inch hex bolt and lock nut from the stop channel on the back of the moldboard and save for reassembly.

Open the frame crate and set aside the power unit box for later assembly.

From the frame assembly, remove the 3/4 inch pivot bolt from the front of the push frame, the 1/2 inch hex bolt and spacer bushing from tabs on the top of the push frame, and the 3/4 inch x 3 inch clevis pin from lugs centered between the prong receivers. Save all hardware for reinstallation.

Snip the plastic tie straps holding the hydraulic cylinders to the push frame and rotate cylinders forward.

Carefully lift the frame assembly by wrapping straps or padded chains around both ends of the 2 1/2 inch square tube at the rear of the frame assembly.

Fasten the frame assembly to the moldboard assembly by lining up holes in the push frame hitch plates with the reinforced center hole through the pivot tube on the back of the plow blade.

14 Plow Assembly

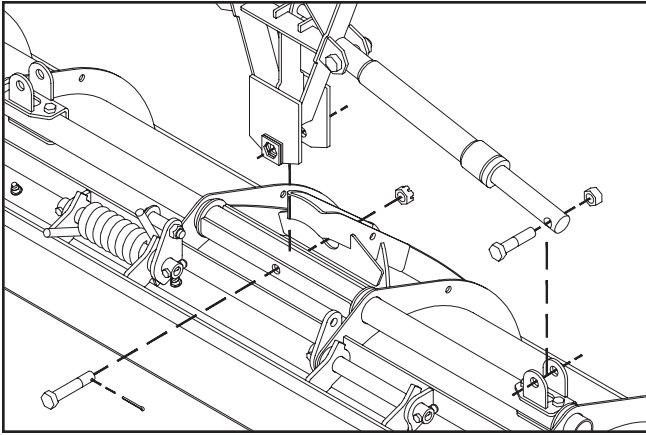

DWG NO. 7473A

Install the 3/4 inch x 4 1/4 inch hex bolt removed earlier so the bolt head is retained by the lock plate on the push frame. Secure the assembly with the 3/4 inch slotted nut and cotter pin so the plow blade is free to pivot.

Fasten the trunnion at the front of the push bar between legs of the stop channel on the moldboard with the 1/2 inch x 4 3/4 inch hex bolt and lock nut removed earlier. Tighten the nut so that the locking feature is engaged, but components are free to pivot.

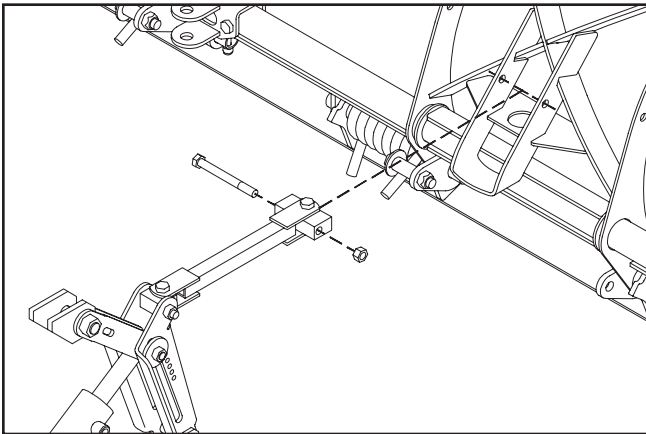

DWG NO. 7474A

Use 3/4 inch x 3 1/4 inch hex bolts and lock nuts to fasten the hydraulic cylinder rods between lugs on the moldboard. Cylinder ports should be directed up.

2. Gently tip the plow assembly to its working position with a hoist or forklift. Pin the parking stand to hold the push frame parallel to the ground.

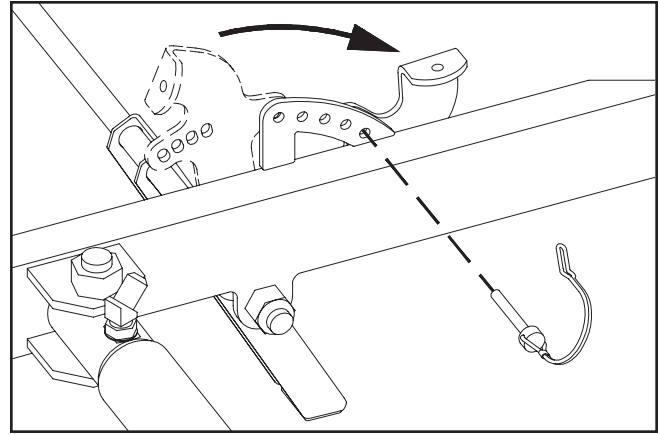

DWG NO. 7472

Swing the lift frame up to its approximate working position and hold with a hoist or forklift for installation of the lift cylinder.

The bottom surface inside the two prong receiver channels should measure about 10 inches above the ground in the working position.

Loosen plugs in the lift cylinder ports to aid in alignment of linkage pin holes.

Pin the base of the lift cylinder between lugs on the frame with the 3/4 inch x 3 inch clevis pin and cotter pin.

Fasten the lower lift links between tabs on the push frame using the 1/2 x 3/4 inch hex bolt, lock nut and spacer bushing removed earlier. Tighten the nut so that the locking feature is engaged, but the links are free to pivot.

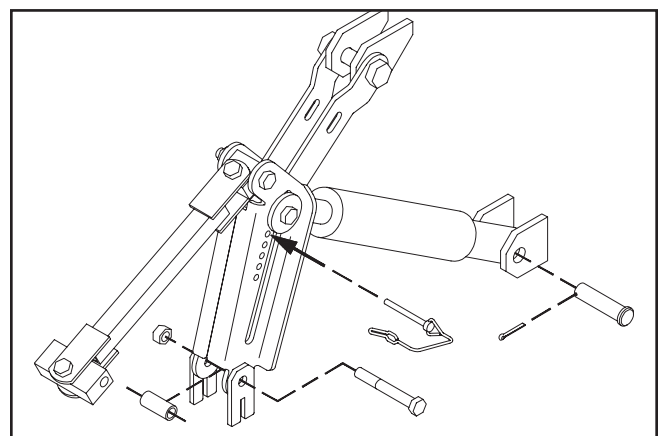

DWG NO. 7476A

Insert a tab lock pin through the hole in the lower link directly below the thick washer to prevent the frame from tipping forward.

3. Locate the 90° and straight adapters for the lift cylinder in the hardware bag from the parts box.

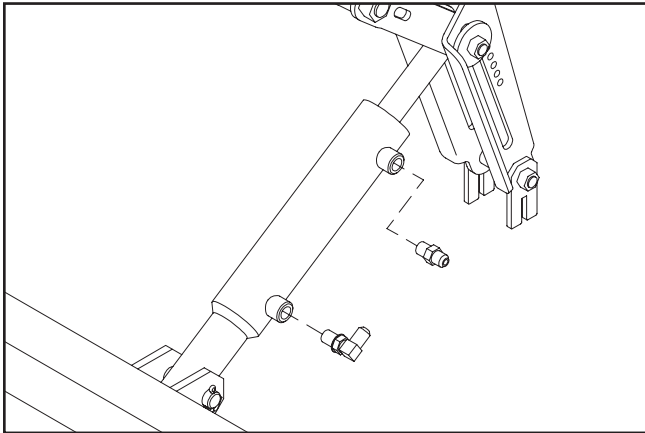

DWG NO. 7490A

Install the O-ring ends of the fittings into ports in the lift cylinder. Direct the 90° fitting toward the rod end of the cylinder.

4. Fasten the power unit onto the drivers side set of holes in the lift frame bracket with two 3/8" x 3/4" hex bolts and lock washers. The plastic reservoir of the power unit should be to the left side of the plow.

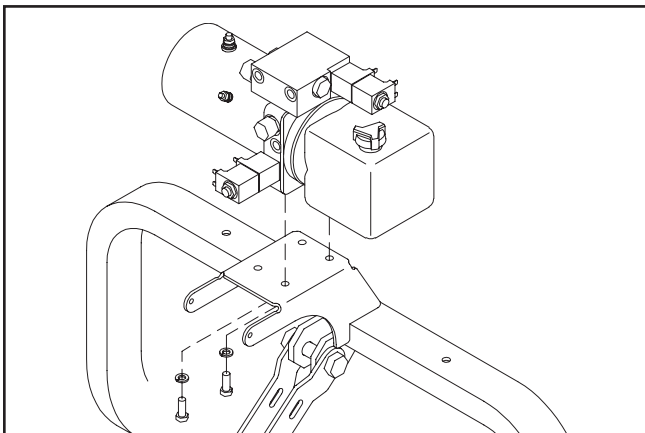

DWG NO. 7477A

Install the four remaining straight adapters from the hardware bag into the four ports in the power unit.

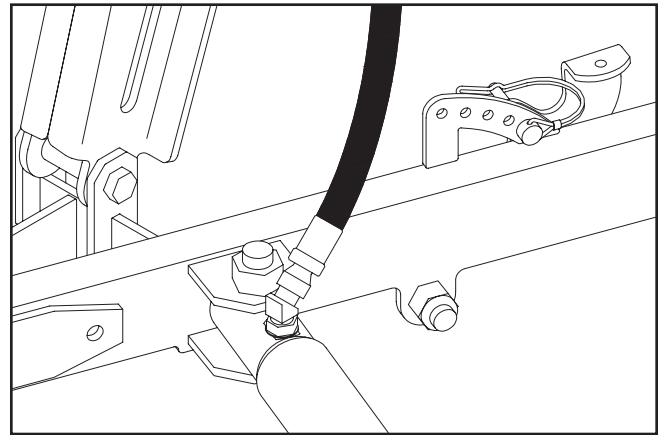

DWG NO. 7478A

Install 45° O-ring/flare adapters into the ports of the angling cylinders so that the flare ends of the adapters are directed straight back.

Four identical hydraulic hoses are in the parts box. Each hose has a swivel nut on each end that will assemble to the adapters from the power unit and three cylinders.

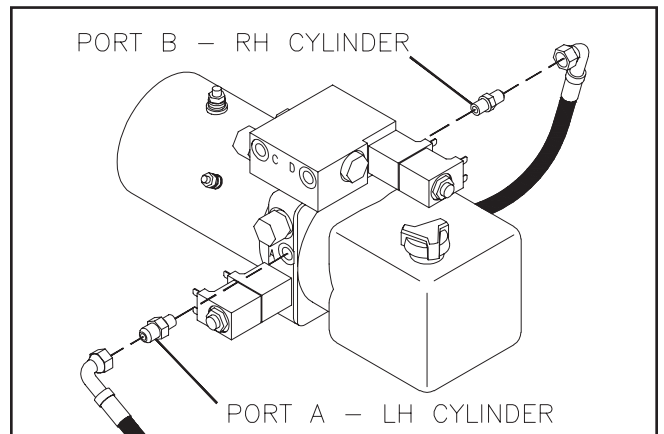

DWG NO. 7479

Connect port A to the LH angling cylinder. Temporarily remove the cap from the relief valve above the port for better wrench clearance.

Connect port B on the back of the power unit to the RH angling cylinder. Route the hose ahead of the lift frame tube.

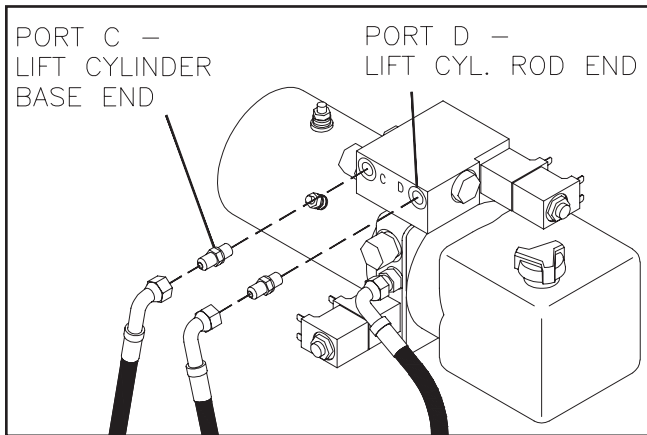

DWG NO. 7480

Connect port C to the base end of the lift cylinder.

Connect port D to the rod end of the lift cylinder.

The fitting in the LH side angling cylinder may have to be adjusted slightly to route the hydraulic hose to best avoid interference with the latch handle and the lift links.

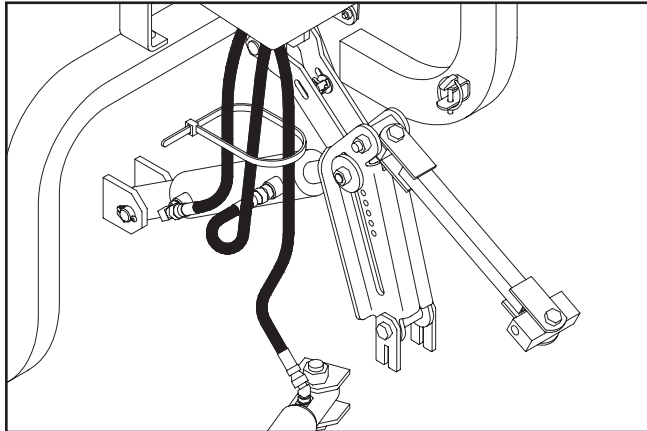

DWG NO. 7481A

Use plastic tie straps to secure hydraulic hoses away from lift linkage components.

5. Fasten the cover strap to the top of the plow frame with two 3/8 inch x 2 1/2 inch carriage bolts and lock nuts from the hardware bag.

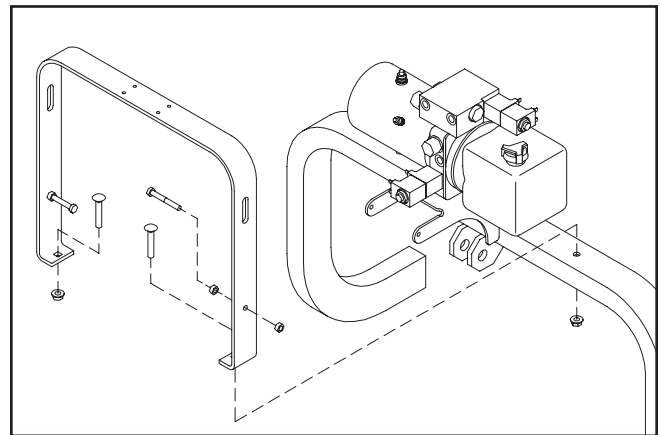

DWG NO. 7482A

Thread a hex nut onto two 5/16 inch x 2 1/2 inch hex bolts before inserting through side holes in the strap. Secure with a second nut to build a rest for the power unit cover.

Insert the indicator rod up through the gap between the power unit bracket and the frame tube.

Pass the lower rod end through the slot in the driver side upper lift link and secure with a 3/8 inch flat washer and cotter pin.

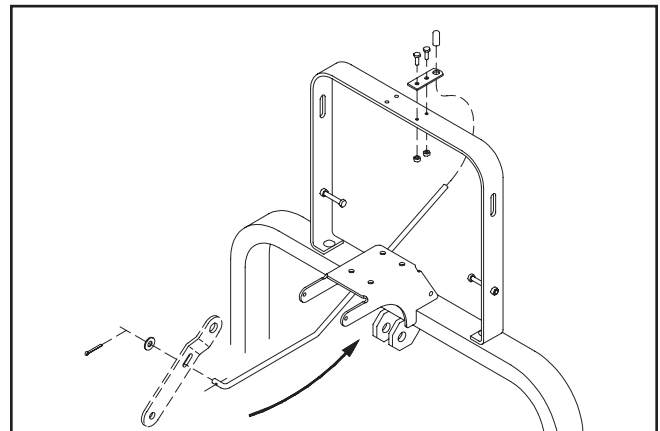

DWG NO. 7483A

Slide the rod guide tab onto the upper end of the rod, then fasten the tab to the driver side set of holes in the strap with two 1/4 inch x 3/4 inch hex bolts and lock nuts.

Press the vinyl cap onto the top of the rod.

ELECTRICAL INSTALLATION

- Identify the plow power cable assembly and plow wiring harness in the parts box. A ground wire harness for the power unit solenoids is in the power unit box.

The power cable for the snowplow has two cables with ring terminals on one end and a two pin connector on the other and measures about 38" long.

The plow wiring harness has a 4-pin connector on one end and the other end has four loose wires with spade terminals.

The ground wire harness has four spade terminals on two wires connected by a ring terminal.

NOTE: To prevent corrosion lightly coat all electrical connections, ring and spade terminals with dielectric grease prior to assembly.

Refer to drawing 7512. Attach the ring terminal of the solid red (or red-striped) wire of the power cable to the terminal on the power unit at location 1.

Fasten the ring terminal of the black wire of the power cable and the ring terminal of the solenoid ground harness to the terminal on the motor at location 2.

Connect the four terminals of the ground harness to solenoids on the power unit.

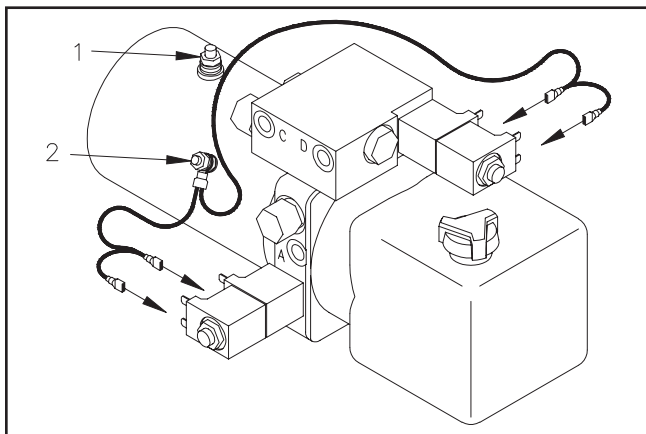

DWG NO. 7512

Refer to drawing 7513.

Connect the tan wire from the wiring harness to solenoid S1. S1 extends the left side of the plow to plow right.

Connect the gray wire from the wiring harness to solenoid S2. S2 extends the right side of the plow to plow left.

Connect the blue wire with the white stripe from the harness to solenoid S3. S3 raises the plow.

Connect the blue wire from the wiring harness to solenoid S4. S4 lowers the plow.

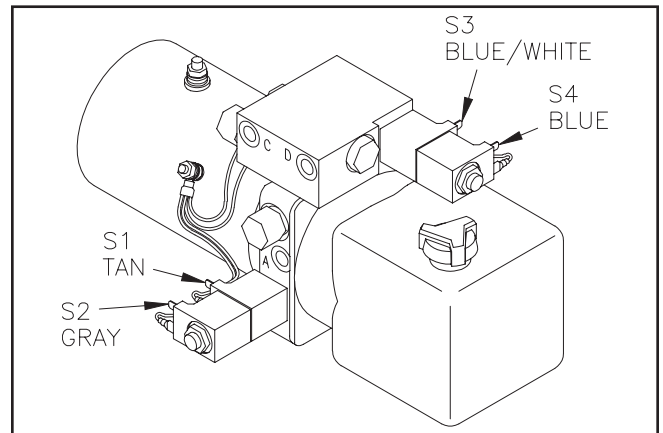

DWG NO. 7513

NOTE: Position the harness so that any trapped water can easily drain away.



WARNING: Disconnect truck battery before beginning electrical installation to avoid shock hazard.

- The motor solenoid, underhood wiring harness, underhood power cable and joystick control box are located in the parts box shipped with the snowplow frame.

NOTE: To prevent corrosion lightly coat all electrical connections, ring and spade terminals with dielectric grease prior to assembly.

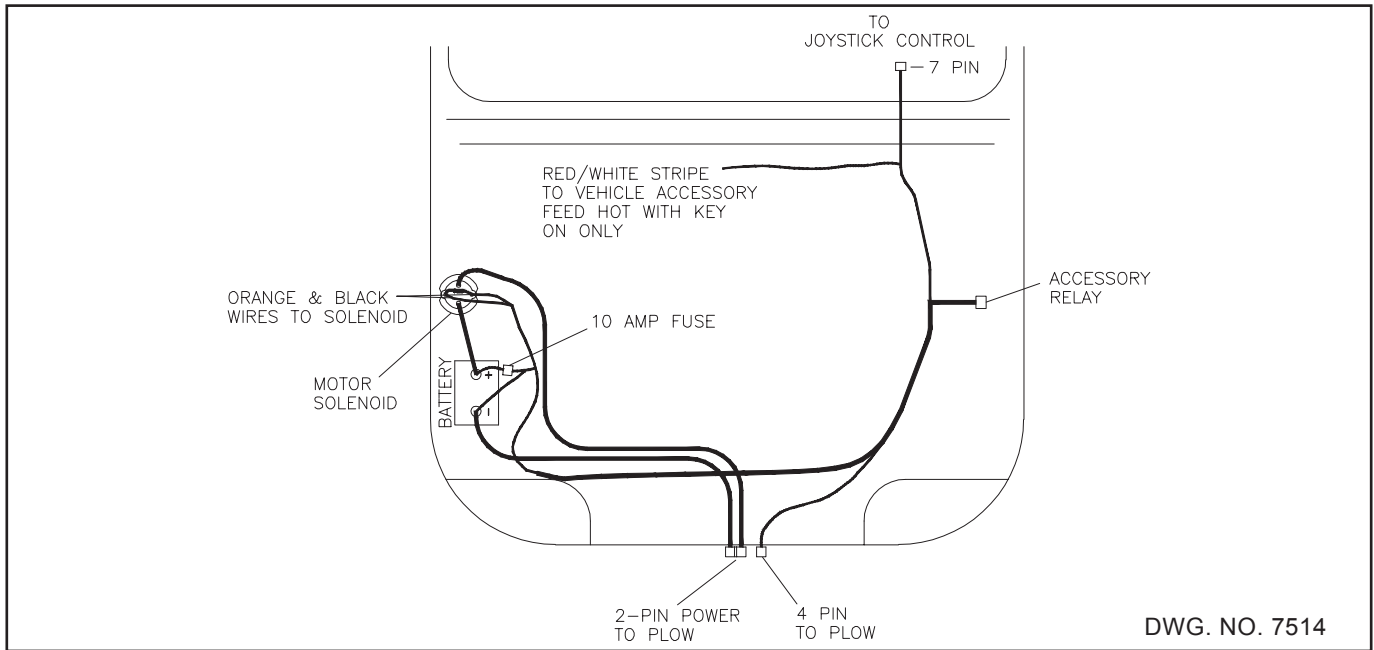

Truck Battery On Passenger Side

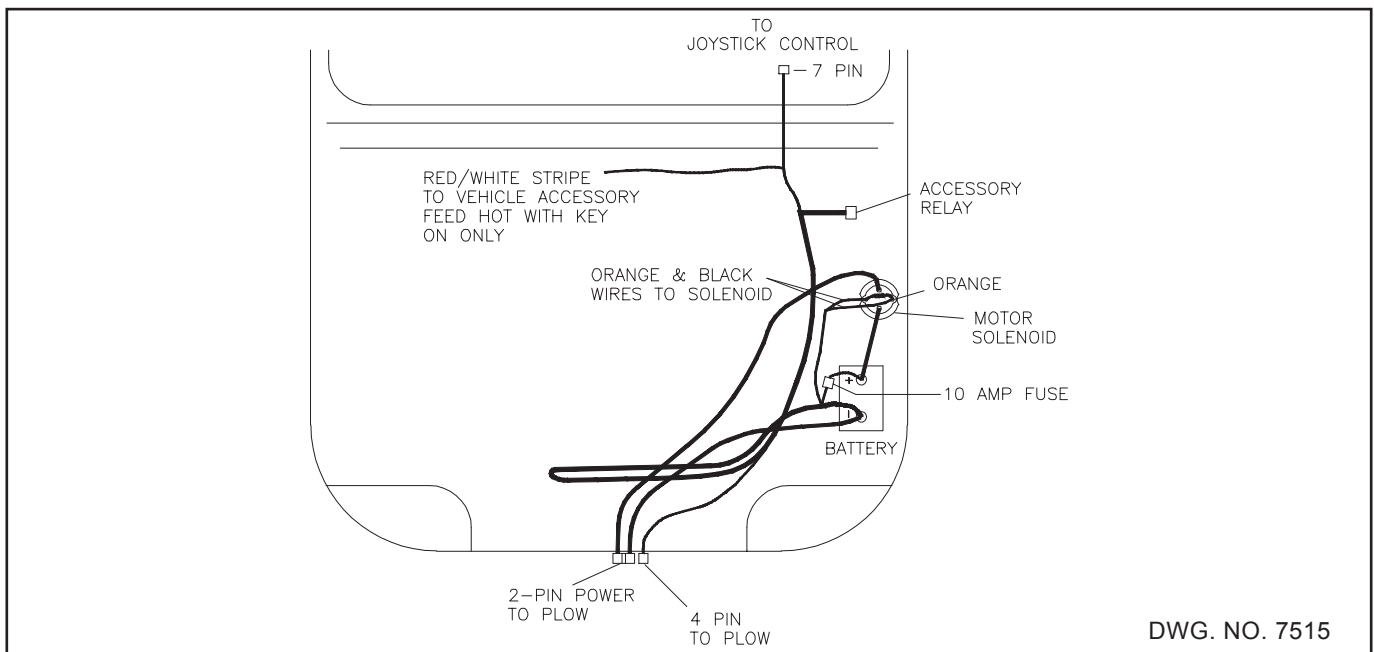

Truck Battery On Driver Side

Refer to drawing 7514 for the trucks with the battery on the passenger side of the vehicle. Lay the underhood harness in its approximate position for final assembly with the 7-pin circular connector near the driver's side firewall. Place the 4-pin connector just left of center near the grill, the relay near the driver's side inner fender. Lay the orange, black and red wires by the battery.

Refer to drawing 7515 for trucks with the battery on the driver side of the vehicle. Coil excess cable away from any moving parts or areas that may get hot, or route it toward the passenger side then double it back.

8. If there is no access hole in the drivers side firewall then drill a 1-1/8 inch diameter hole. Route the 7-pin circular connector through the firewall into the cab compartment and install the 4 inch grommet in the hole, if required.



CAUTION: Ensure that the relay will clear any hood lift/spring mechanisms before installation.

9. Select an area near the driver's side inner fender to mount the relay. Drill a 1/8" diameter hole and secure the relay using a #8 x 1 1/2" self tapping screw from the hardware bag in the parts box. Apply a light coat of dielectric grease on the relay contacts before inserting into the holder.

NOTE: Mount the relay with the wires pointing down to prevent contamination.

10. Splice the red with white stripe wire to the vehicle's switched 12 volt auxiliary electrical circuit to prevent operation of the plow without the vehicle key being on. This wire controls the accessory relay that powers the control joystick and solenoids.



CAUTION: To prevent injury or property damage caused by unintentional plow movement when the key is removed from the vehicle, the red/white striped wire must be connected to a switched power source on the vehicle. Connecting to a power source not controlled by the ignition switch will allow movement of the plow with the vehicle key removed.

11. Connect the joystick control box to the 7-pin connector inside the truck cab. Secure the box at a safe location in the cab with the strip of hook and loop fastener.



WARNING: Ensure that the motor solenoid and associated wiring will clear any hood lift/spring mechanisms before installation.



IMPORTANT: Do not over tighten nuts on the motor solenoid terminals. Over-tightening causes premature solenoid failure. Refer to torque specifications on the solenoid.

12. Select an area within 16 inches of the vehicle battery for the motor solenoid. Using the solenoid as a template, mark then drill two 3/16" diameter holes and fasten the solenoid with two 1/4 inch x 1/2 inch long self tapping screws from the hardware bag in the parts box.

Connect the Black wire of the underhood harness to one of the small posts on the solenoid. Connect the Orange wire to the remaining small post, polarity is not important.

13. Safely route the 4-pin connector through the grill of the vehicle to a location that will be easily accessible with the plow attached.

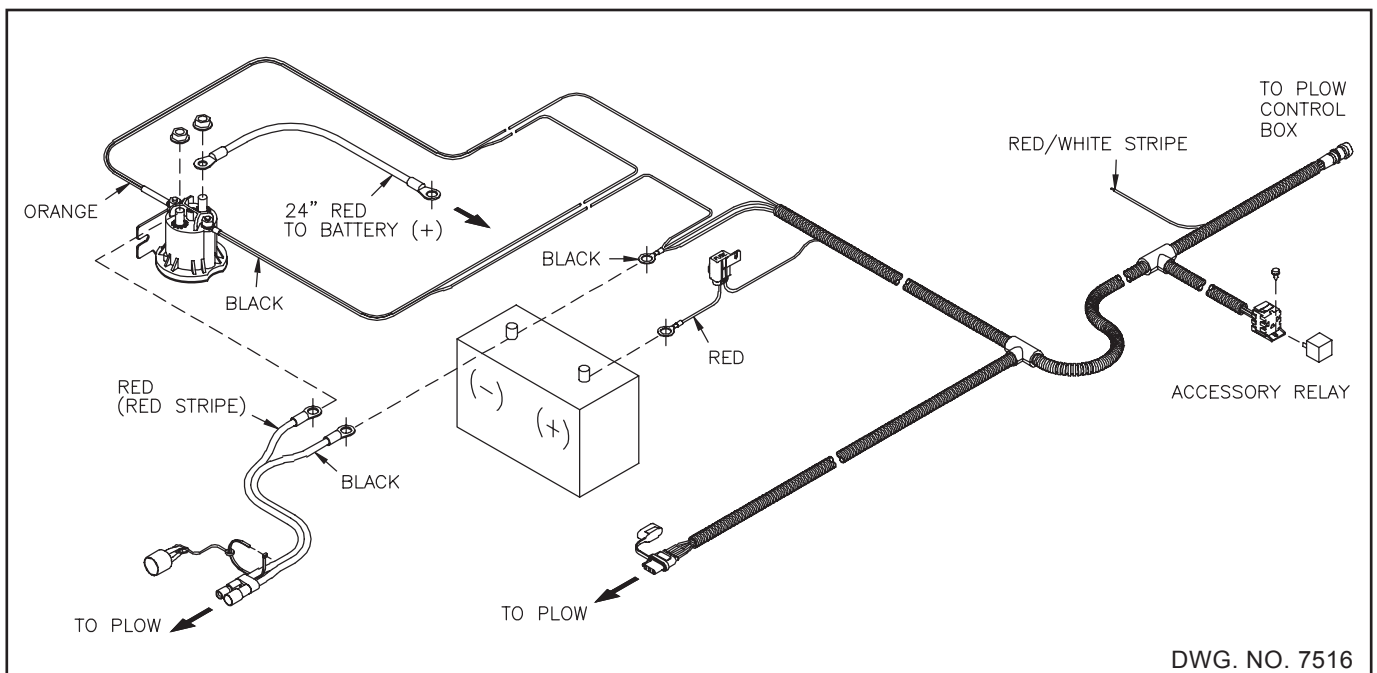

14. Refer to drawing 7516. Install the underhood power cable by first connecting the Black cable and the three Black wires from the harness to the minus (-) post of the vehicle's battery. Connect the Red (or Red striped) cable to the motor solenoid. Route the power cable to the grill near the 4-pin connector.

Connect the Red fused wire from the harness and the 24 inch Red cable to the plus (+) terminal of the battery or battery access post. Connect the other end of the 24 inch Red cable to the motor solenoid.

15. Secure all cables away from hot or moving components with cable ties.

This completes the electrical installation.

20. At this point, the mount kit should be assembled onto the truck.

Prongs from the truck mount kit should be at a height that will slightly lift the plow frame when attaching the plow. Prong receivers on the plow frame should be parallel to the ground when attaching the plow. Apply powered graphite on the truck prongs to help the plow to slide on and off more easily.

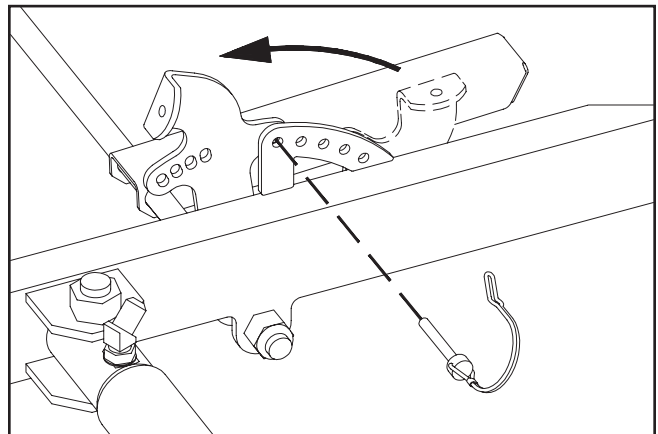

DWG NO. 7463

Raise the parking stand to its highest position and repin.

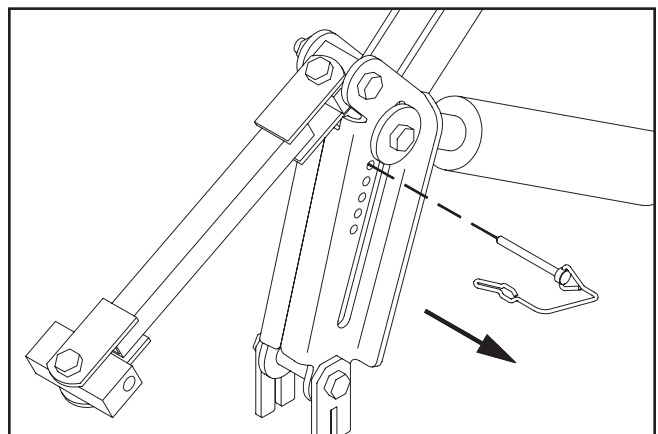

DWG NO. 7464A

Remove the pin from the lower lift link and store it in the parking stand lever.

Connect the two electrical cables from the plow to their corresponding receptacles on the truck.

Select Hiniker Cold Flow Hydraulic Oil, or an equivalent oil that meets military specification 5606 for plowing in extremely cold temperatures.

Pour hydraulic oil into the power unit oil reservoir until the oil level reaches the fill line.

Angle the plow full left and right with the cab control box to fill the angling cylinder with oil.

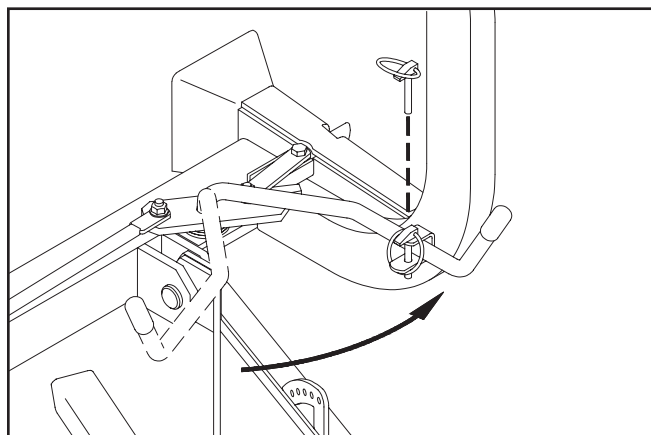

Handle Pinned With Plow on Truck DWG NO. 5691

Attach the plow onto the truck by driving the truck prongs into the receivers on the plow frame. Pull the latch handle into the frame clevis to move sliders through the notches in the prongs and receivers. Pin the handle in the clevis with its klik pin.

Add oil to the reservoir until the oil again reaches the fill line, then raise and lower the plow to fill the lift cylinder with oil.

Cycle the plow left and right and up and down to purge any air trapped in the hydraulic system.

Check the oil level with the plow on the ground. Add oil to the fill line, if necessary, but do not overfill the reservoir.

NOTE: New hydraulic angling cylinders will leak a small amount of oil until packings become saturated and produce a good seal. If leakage is excessive, or if leaking continues after initial cycling, tighten the cylinder packing nut in 1/8-turn increments until leaking stops.

21. Fasten the power unit cover onto the lift frame bracket with two 1/4" x 3/4" screws, flat washers and lock nuts from the hardware bag in the parts box. Tighten the lock nuts so that the assembly is secure, yet the cover hinges freely.

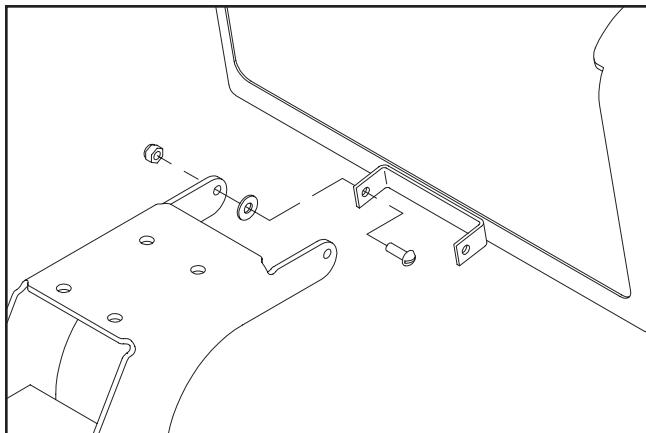

DWG NO. 7486

When the cover is closed, release the latch handles so that rod ends extend through slots in the strap to hold the cover in place.

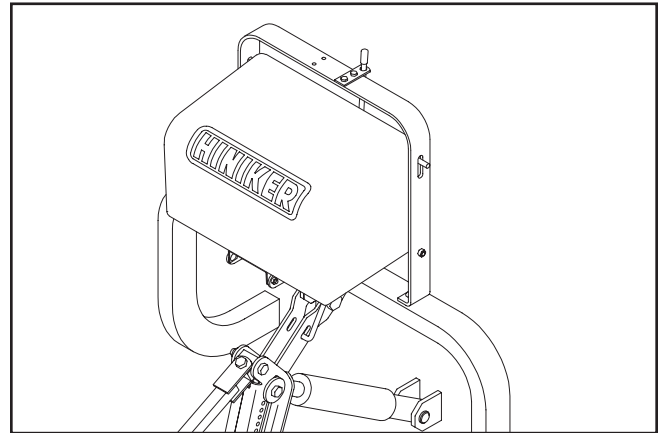

DWG NO. 7487A

22. Assemble side markers on the ends of the moldboard with 5/16 inch bolts, flat washers and lock nuts.

SYSTEM CHECK-OUT

NOTE: The power cable and wiring harness must be connected between the snowplow and truck to test the functions of the power unit. Vehicle ignition must be switched on.

Move the power switch on the joystick controller to the "On" position.

In an area clear of bystanders, test joystick functions by raising and lowering the plow and angling side to side.

To reverse the angle functions, exchange the tan and gray wires on the power unit.

Raise and lower functions may be reversed, as follows.

JOYSTICK CONFIGURATION

As supplied from the factory, the snowplow controller raises the plow when the joystick is pulled backward and lowers the plow when the joystick is pushed forward. These functions can be reversed by reassembling the joystick switch and face plate.

To reverse the face plate, pry the plate away from the controller by inserting a small screwdriver along the side of the plate at location 1 in drawing 7475. Flip the plate over, then reinstall by gently squeezing the long sides together and sliding the four tabs into slots in the controller top.

To reverse the joystick switch, remove four screws from the back of the controller and remove the main circuit board assembly from the case halves.

Gently pull on the edges of the small circuit board at the base of the joystick switch to remove the switch from the five pins on the main circuit board.

Rotate the switch 90°, then gently push the switch back onto the five pins.

Insert the main circuit board assembly back into the case top, making sure the joystick is properly seated and the harness strain relief is inside the case.

Reassemble the case with the four screws, checking that wires are not pinched between bosses.

Test the controller on the snowplow or a plow tester to verify that raise and lower functions match arrows on the face plate.

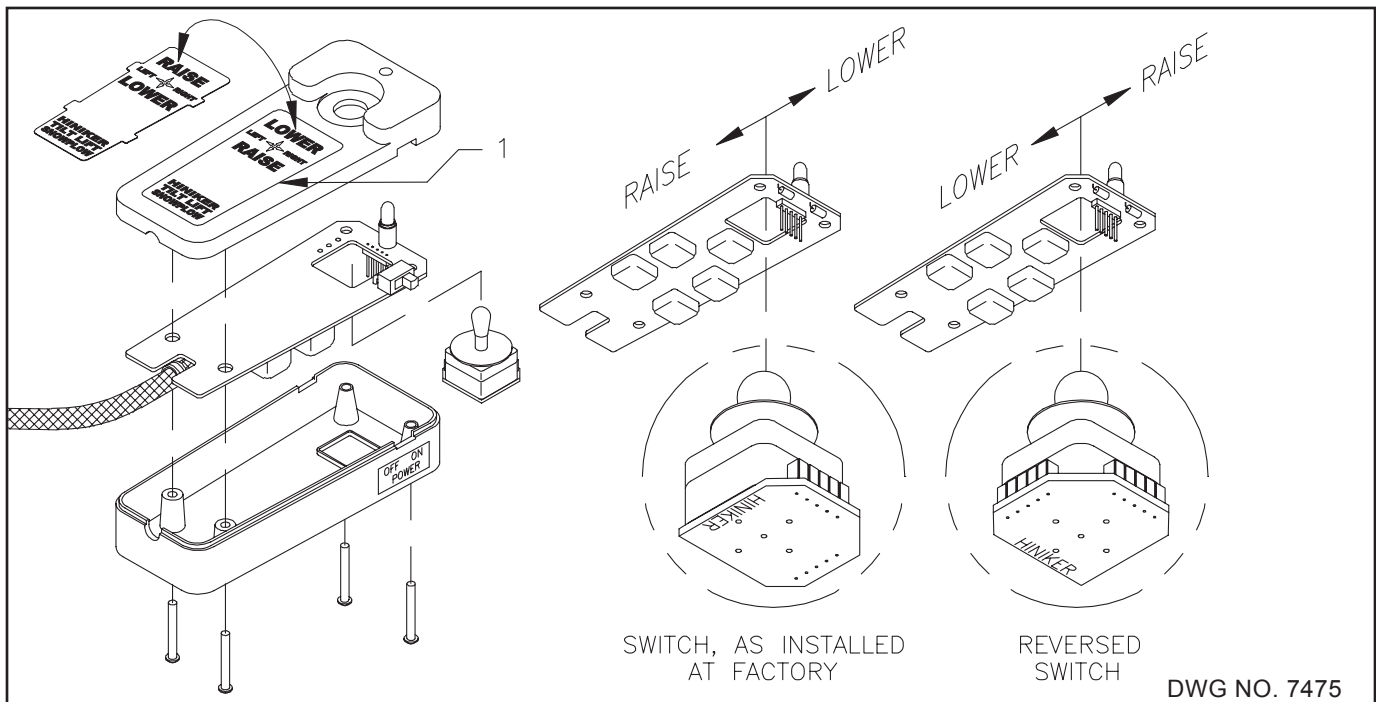

SPECIFICATIONS

	Model 1700SS 7' Plow	Model 1750SS 7 1/2' Plow
Blade Width	7'	7 1/2'
Plow Width at 25°	6'4"	6' 9 1/2"
Blade Height	26"	
Cutting Edge	1/4" x 6" 1084 steel w/standard highway punch	
Weight	469 lbs.	481 lbs.
Recommended Hydraulic Fluid	Hiniker Cold Flow Mil Spec 5606 or Equivalent	
Hydraulic Fluid Capacity	2 Quarts	
Motor Solenoid	12 VDC solenoid continuous duty, sealed	
Wiring Harness Fuse	10 AMP	
Hose Ends	9/16-18 JIC Female Swivel	

CAB CONTROL

J1

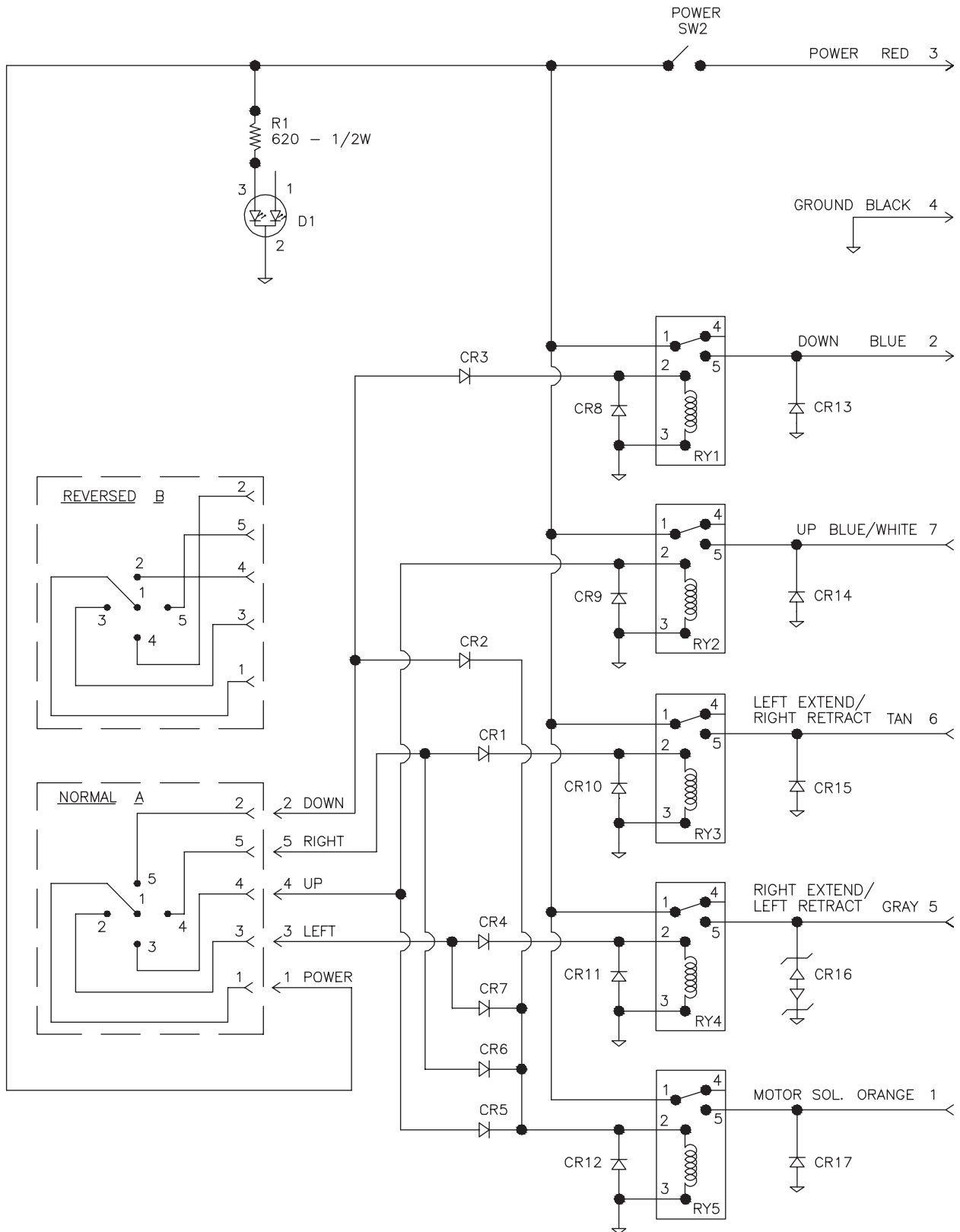

UNDERHOOD HARNESS

EXTERNAL HARNESS

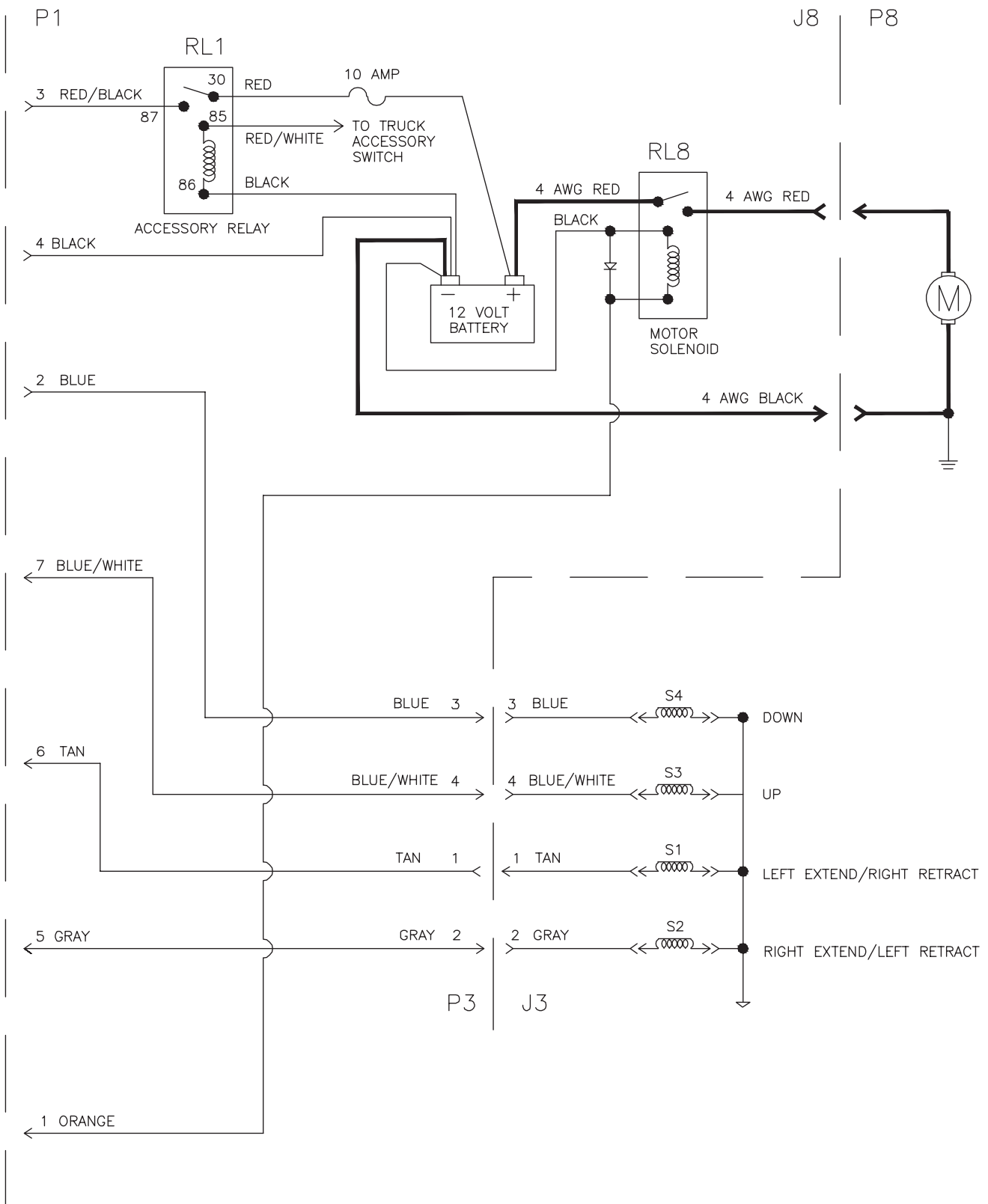

STRAIGHT FLOW POWER UNIT

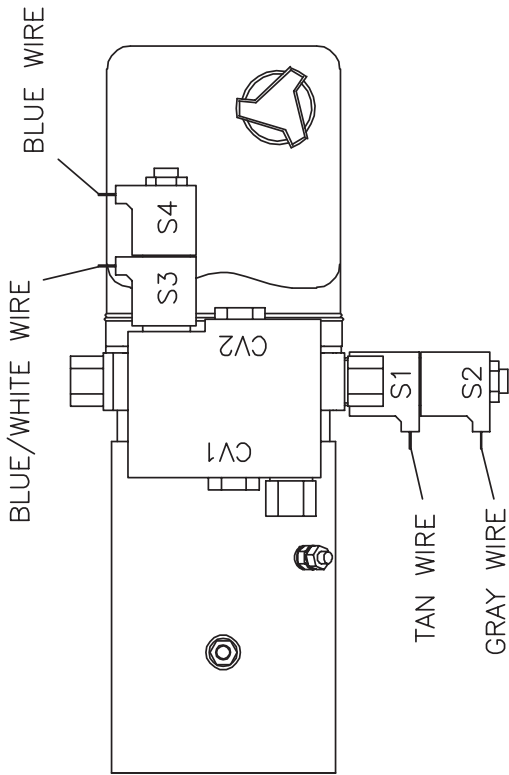

- SYS RV - SYSTEM RELIEF VALVE 2000 PSI
- RV1 - RELIEF VALVE RH CYLINDER 2100 PSI
- RV2 - RELIEF VALVE LH CYLINDER 2100 PSI
- RV3 - RELIEF VALVE RAISE/LOWER CYLINDER 1500 PSI

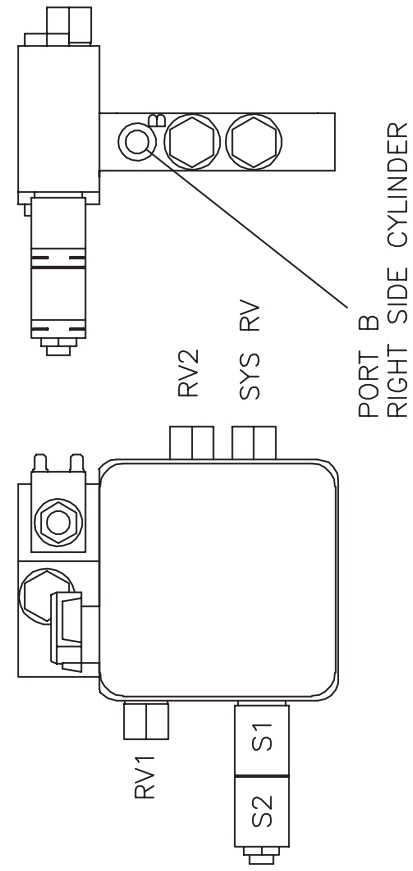
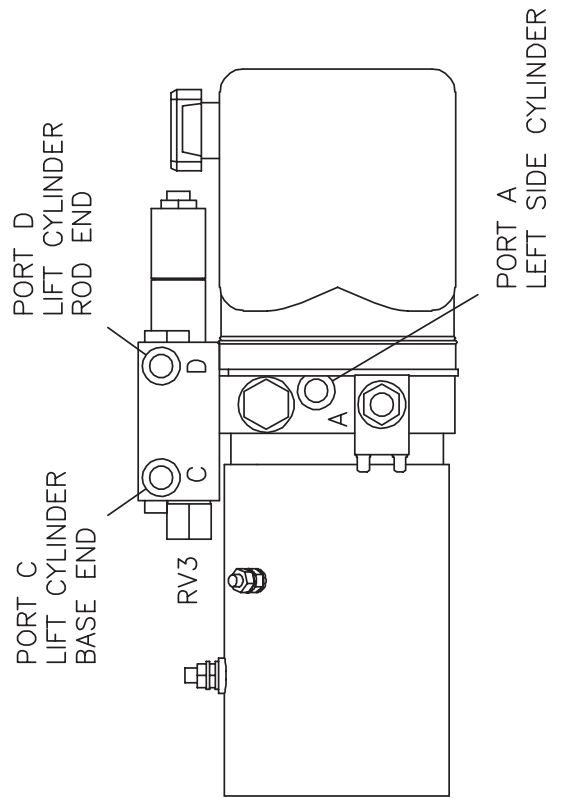

POWER UNIT HYDRAULIC CIRCUIT DIAGRAM

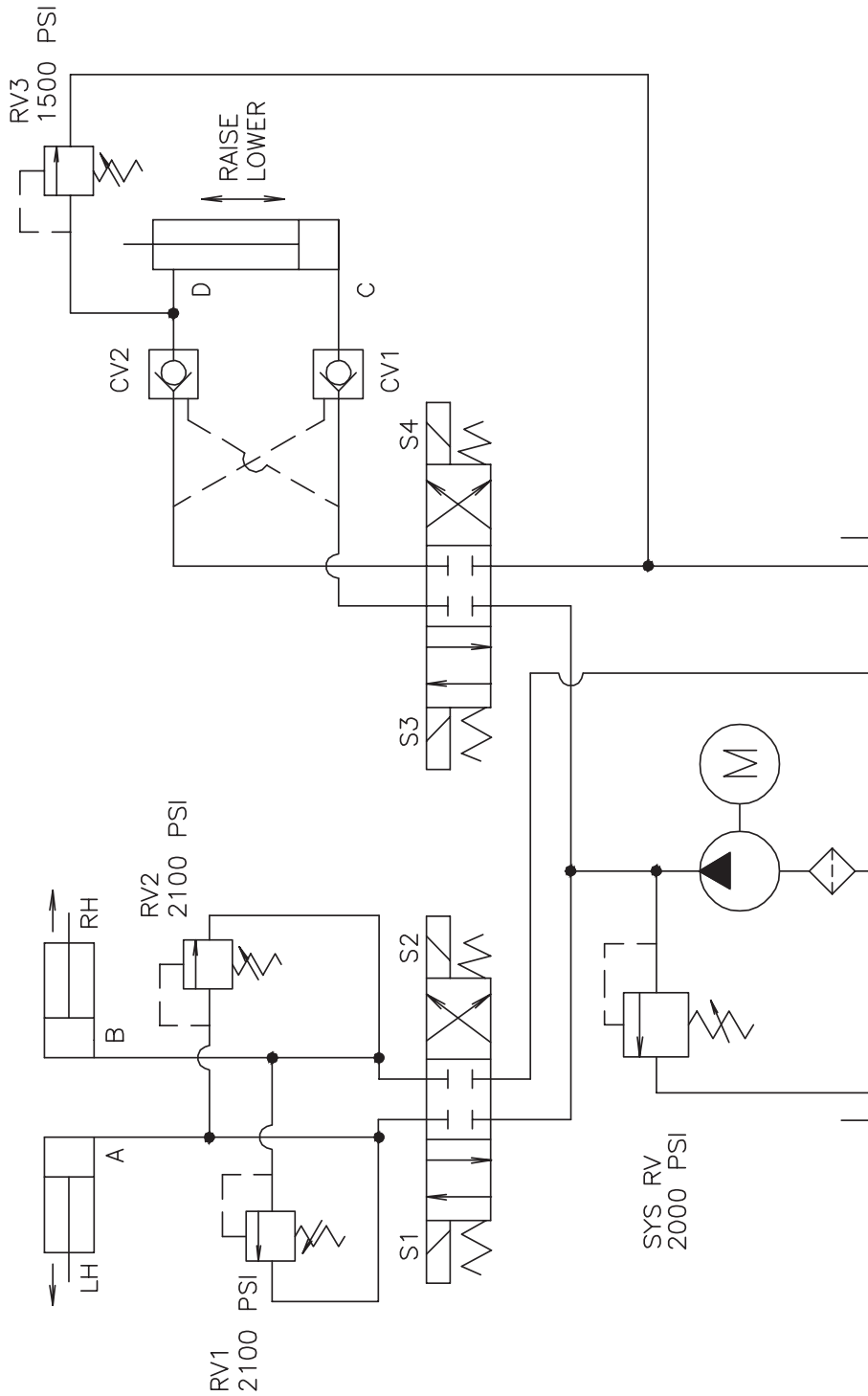

- S1 - LEFT EXTEND/RIGHT RETRACT - TAN WIRE
- S2 - RIGHT EXTEND/LEFT RETRACT - GRAY WIRE
- S3 - UP - BLUE/WHITE WIRE
- S4 - DOWN - BLUE WIRE

HINIKER WARRANTY

HINIKER SNOWPLOW LIMITED WARRANTY

The only warranty Hiniker Company (Hiniker) gives and the only warranty that any Hiniker dealer is authorized to give on behalf of Hiniker is as follows: **(NO EMPLOYEE OR REPRESENTATIVE IS AUTHORIZED TO CHANGE THIS WARRANTY IN ANY WAY OR GRANT ANY OTHER WARRANTY.)**

Hiniker warrants to the original purchaser of a Hiniker snowplow that Hiniker will repair or replace any defects in material and workmanship that occur within two years from date of retail delivery except the following items: Hiniker warrants that it will repair or replace any defects in materials or workmanship with respect to the paint finish, any accessories, and service parts and components for a period of one year from date of retail delivery.

Hiniker's obligation and liability under this warranty is expressly limited to repairing or replacing, at Hiniker's option, at an authorized Hiniker dealer location, the defective parts at no charge to the original purchaser. **HINIKER MAKES NO OTHER WARRANTY, EXPRESS OR IMPLIED AND MAKES NO WARRANTY OF MERCHANTABILITY OR OF FITNESS FOR ANY PARTICULAR PURPOSE.**

HINIKER'S OBLIGATION UNDER THIS WARRANTY SHALL NOT INCLUDE ANY TRANSPORTATION CHARGES TO OR FROM THE AUTHORIZED HINIKER DEALER LOCATION OR ANY LIABILITY FOR INCIDENTAL, INDIRECT OR CONSEQUENTIAL DAMAGE OR DAMAGES OF ANY KIND FOR LOST PROFITS OR DELAY. If requested by Hiniker, products or parts for which a warranty claim is made are to be returned freight prepaid to our factory. Any improper use, operation beyond rated capacity, substitution of parts not approved by Hiniker Company, or any alteration or repair in such manner as in our judgment affects the product materially and adversely shall void this warranty.

Hiniker reserves the right to make improvements or changes to any of its products without notice. Such improvements or changes shall not trigger any obligation by Hiniker to update, modify or change any products previously sold by Hiniker.

HINIKER does not warrant the following:

1. Used products.
2. Any product that has been repaired, modified or altered in a way not approved by Hiniker Company.
3. Depreciation or damage caused by normal wear, lack of reasonable and proper maintenance, failure to follow Operators Manual Instructions, misuse, lack of proper protection during storage, or accident.
4. Parts replacement and service necessitated by normal wear or maintenance including, but not limited to, cutting edges, hoses, snowplow skid shoes, blade marker guides and hardware.
5. Paint finish damage caused by normal wear.

Hiniker does not assume any liability for any damage to a motor vehicle resulting from the attachment or use of a Hiniker snowplow. Compliance with applicable motor vehicle regulations is the responsibility of the installer. Attachment of a Hiniker snowplow to a motor vehicle is at the risk of the purchaser.

It is the responsibility of the original snowplow purchaser to verify the original date of purchase.

A DELIVERY REPORT FORM must be filled out and received by Hiniker with 30 days of retail delivery at the address below to initiate the warranty coverage.

HINIKER COMPANY
58766 240th St.
P.O. Box 3407
MANKATO, MN 56002-3407
PHONE (507) 625-6621 -- FAX (507) 625-5883
www.hiniker.com

