



PICKUP TRUCK SNOWPLOW

Models 702, 752, 702SS, 752SS

OPERATOR'S MANUAL

**DO NOT USE OR OPERATE THIS EQUIPMENT UNTIL THIS MANUAL
HAS BEEN READ AND THOROUGHLY UNDERSTOOD**

PART NUMBER 25013142 Rev. D

TABLE OF CONTENTS

25013142 Rev. D

6/20

Hiniker/25013142RevD

TO THE PURCHASER.....	2
SAFETY.....	3
OPERATING PROCEDURES.....	4
TROUBLE SHOOTING.....	9
MAINTENANCE.....	11
ASSEMBLY.....	13
SYSTEM CHECKOUT AND JOYSTICK CONFIGURATION.....	22
HEADLAMP AIMING PROCEDURE.....	23
ELECTRICAL CIRCUIT.....	24-25
HYDRAULIC CIRCUIT - SPX.....	26-27
HYDRAULIC CIRCUIT - KTI.....	28-29
SPECIFICATIONS.....	30
WARRANTY.....	31

TO THE PURCHASER

This product is designed and manufactured to give years of dependable service when properly maintained and used for the purpose for which it is intended. Never allow anyone to operate this equipment until they fully understand the complete contents of this manual. It is the responsibility of owners who do not operate this equipment to ensure the operator is properly instructed and understands the contents of this manual. It is also the owner's responsibility to ensure that anyone operating this equipment is mentally and physically capable of so doing.

Important information is contained in this manual to help ensure safe and efficient operation.

If you have any questions about this manual, or the equipment discussed herein, contact your Hiniker dealer.

 **TAKE NOTE! THIS SAFETY ALERT SYMBOL FOUND THROUGHOUT THIS MANUAL IS USED TO CALL YOUR ATTENTION TO INSTRUCTIONS INVOLVING YOUR PERSONAL SAFETY AND THE SAFETY OF OTHERS. FAILURE TO FOLLOW THESE INSTRUCTIONS CAN RESULT IN INJURY OR DEATH.**

 **THIS SYMBOL MEANS:**
- ATTENTION!
- BECOME ALERT!
- YOUR SAFETY IS INVOLVED!

 **SAFETY SIGNAL WORDS:**

DANGER: Indicates an imminently hazardous situation that, if not avoided, will result in death or serious injury.

WARNING: Indicates a potentially hazardous situation that, if not avoided, could result in death or serious injury.

CAUTION: Indicates a potentially hazardous situation that, if not avoided, may result in minor or moderate injury, or damage to components.

NOTE: Addresses safety practices not related to personal safety.

All references to Left or Right are defined as viewing the plow from the cab of the truck.

Instructions for raising and lowering the plow refer to the joystick controller as received from the factory. The raise and lower functions may be reversed to suit the preference of the operator by following the instructions on page 22 for switching the controller joystick and face plate.

This Operator's Manual is shipped with this equipment. Contact your Hiniker dealer for additional copies.

Always obtain original Hiniker service parts. Substitute parts could adversely affect equipment performance and warranty.

Check that your dealer has forwarded the Hiniker delivery report form along with the plow identification number because it helps maintain maximum service and warranty benefits. This does not put you on any mailing list, and information thereon is not available to others.

Your plow's identification number plate is at location (1) in the following illustration.

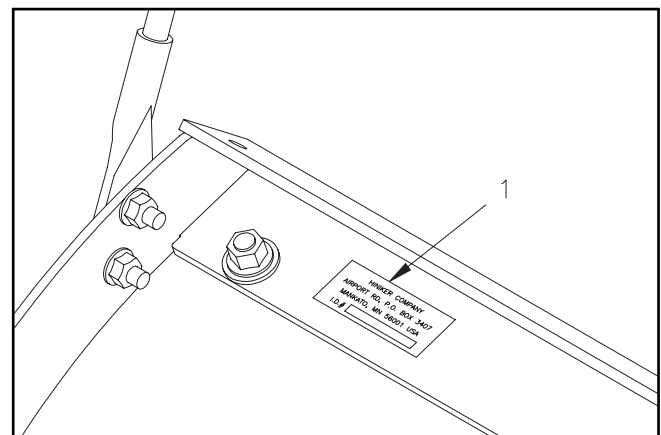

DWG NO. 5689

Record the following information for later reference when obtaining service parts:

Purchase Date _____

Purchaser's Name _____

Dealer's Name _____

Machine I.D. No. _____

SAFETY



This is a safety alert symbol. It alerts an operator to information concerning personal safety. Always observe and heed these symbols and instructions, otherwise death or serious injury can result.

Operator safety is a principle concern in equipment design and distribution. However, many accidents occur because a few seconds of thought, and a more careful approach to handling, were ignored.

Accidents can be avoided by knowing and following the precautions cited in this manual.

GENERAL SAFETY

1. Read this manual thoroughly. Make sure the operator understands it and knows how to operate this equipment safely. This equipment can kill or injure an untrained or careless operator and bystanders. If you sell this equipment, ensure the new owner acknowledges receipt of this manual.
2. This plow is intended for plowing snow only. Plowing gravel, rocks, etc., or using the plow for any purpose other than plowing snow could result in harm to the operator or bystanders or cause damage to the plow or vehicle, and will void the warranty.
3. Do not service or otherwise handle a plow in the raised position unless it is securely blocked against unexpected falling.
4. Do not attempt to handle or service this equipment, or direct others to do the same, unless you know how to do it safely and have the proper tools for the job.
5. Keep hands, feet, hair, and clothing away from moving parts.
6. Do not alter the equipment to the extent of compromising safety or performance.

BEFORE OPERATION

1. Discipline yourself to visually check for worn, damaged or cracked parts before starting use. Replace these with genuine Hiniker parts.
2. Escaping hydraulic oil under pressure can penetrate the skin, causing serious injury. Do not use your hand to check for leaks. Use a piece of paper or cardboard to find suspected leaks. Tighten all connections before pressurizing hydraulic lines.

If fluid is injected into the skin, get medical attention immediately to prevent serious infection.

3. Check all controls and operating functions of the machine in a safe area before starting to work.

DURING OPERATION

1. Always wear seat belts when operating a motor vehicle.
2. Ensure everyone is clear of the machine, especially away from blind areas of the operator, before starting, actuating hydraulics or operating this equipment.
3. Do not plow snow at excessively high speeds.
4. Avoid hitting objects that will damage your plow or truck.
5. Set the brakes and stop the truck's engine before adjusting or servicing your plow.

AFTER OPERATION

1. Park the plow on a solid, level surface. Fully collapse the lift cylinder and use the stop plate, as described on page 7, before unhitching the plow to prevent the frame from falling forward.

OPERATING PROCEDURES

ATTACHING THE PLOW

Attachment prongs on the truck should be mounted such that the bottom edge of the prongs measure about 10 inches above the ground. Prong receivers on the plow frame should remain parallel to the ground and at the correct height by fully retracting the lift cylinder with the upper lift links and bracing the frame with the stop plate before removing the plow from the truck (See "Removing the Plow"). Ideally, the prongs on the truck should lift the plow frame slightly when driving into the plow for attachment.

Powdered graphite applied on the prongs will help the plow slide on and off more easily.

Check that prongs are in line with the receivers before slowly driving into the plow. Set the parking brake in the truck to prevent it from creeping back out from the receivers.

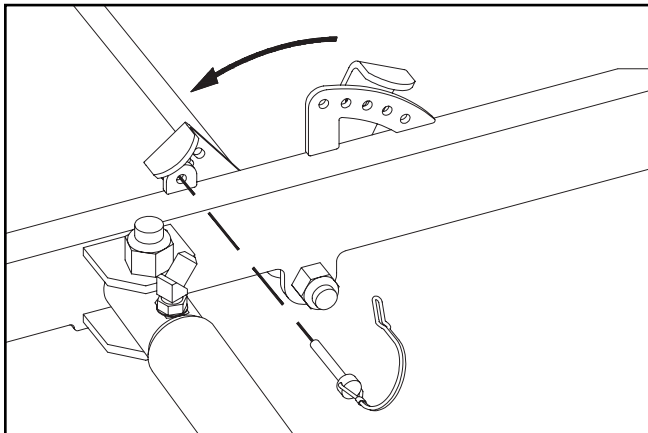

DWG NO. 5690

Remove the tab lock pin from the indexing hole and raise the parking stand to its highest position. Repin the stand lever to the front hole in the push frame for transport.

Pull the latch handle into the clevis on the lift frame to force the sliders through the notches in the prongs and receivers. Check that both sliders are fully engaged.

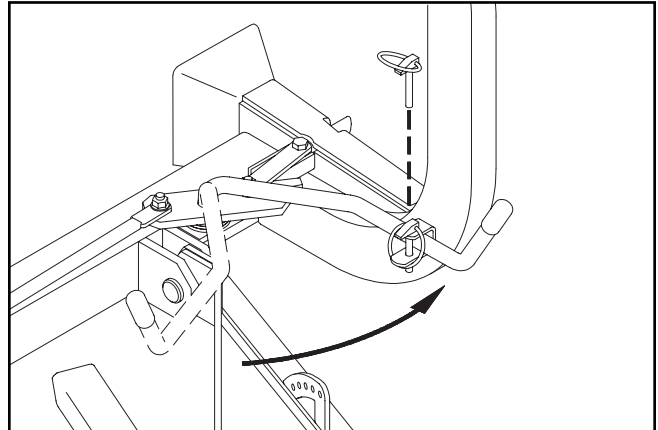

Handle Pinned With Plow On Truck DWG NO. 5691

Pin the handle in the clevis with its klik pin. Failure to pin the handle in place may allow the plow to fall off the truck.

NOTE: Before connecting the plow's wiring to the truck, make sure power is switched "Off" on the joystick controller.

Plug in the two electrical connectors between the plow and the truck after latching the plow. The alignment tab on the 16-pin plug will mate with the slot on the mating receptacle to ensure proper connection.

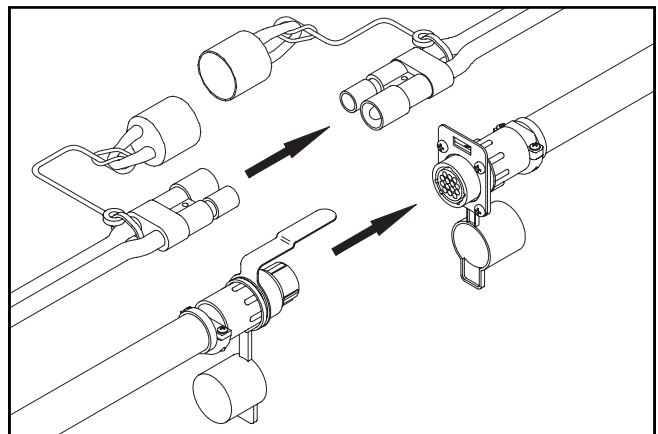

Alignment Tab and Slot DWG NO. 6697

Check that the plow headlamps and turn signals are operational, and headlamps are aimed correctly. Test the lift and angling cylinders in a safe area before using the plow.

To make alignment of the plow easier in the future, mark a point on the back of the headlamp, a point on the hood near the front of the truck and a point on the windshield that are in line when you are seated behind the steering wheel. Line up these three points when driving into the plow.

THE JOYSTICK CONTROLLER

The joystick control box has slide switches for controlling power to the snowplow and for switching from the truck headlights to the headlights on the plow.

The joystick controller raises and lowers the plow and angles the blade left or right.

NOTE: Drawings 4176 and 4177 show the raise and lower functions of the joystick controller as received from the factory. Functions may be reversed to suit the preference of the operator by following the instructions on page 22 for switching the controller joystick and face plate.

The vehicle's electrical power must be turned on before the control box will function.

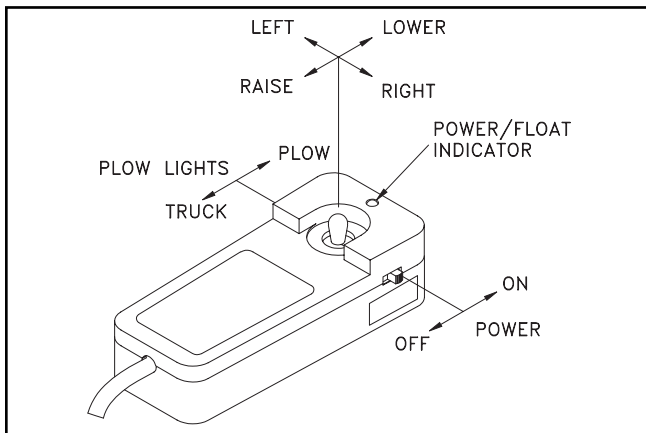

Joystick Control Box

DWG NO. 4176

Place the on/off switch on the joystick control box in the "on" position to supply power to the snowplow. A green light will indicate power is on.

Move the headlight slide switch on the control box to the "plow" position to change from the truck lights to the snowplow lights.

Activate high beam/low beam and turn signal/parking lamps from the truck as you normally would without the plow attached.

NOTE: When removing the plow, remember to place the headlight switch in the "truck" position to return power to the truck's headlights.

Raise or lower the plow by moving the joystick to the "raise" or "lower" position.

Hold the plow at an intermediate height by releasing the controller from the "raise" position when the plow reaches the desired height.

Moving the controller to the "lower" position will lower the blade to the ground and allow the plow to "float" along the contour of the ground while plowing snow.

A yellow light on the control box indicates the plow is in the float mode. Momentarily moving the joystick to the "raise" position will remove the plow from the float condition and the yellow indicator will return to green.

Move the joystick left or right to angle the blade. Release the joystick when the blade is at the desired angle.

TRANSPORTING THE PLOW

The extra weight of the snowplow on your truck will impair handling response and increase braking distance. The plow will also block some airflow to the vehicle's cooling system, possibly causing the vehicle to overheat. Therefore, it is important not to exceed speeds above 45 mph when the plow is attached.

Remove the plow if you must drive your truck for long distances when the temperature is warm.

Raise the blade to a position where it will not interfere with the headlights before driving.

Transport the plow with power to the joystick control box switched off to prevent accidental lowering of the plow.

Never adjust the blade height or angle the blade while driving.

PLOWING SNOW



WARNING: Always wear a seat belt when plowing snow. Sudden contact with a hidden object can result in serious personal injury.

Inspect areas to be plowed before snowfall for potential hazards, and mark obstructions with stakes that will be seen when snow covers the ground. Identify any emergency equipment and utility outlets that may need to be cleared in the event of a storm. Prepare a plan beforehand for clearing snow from tight or enclosed areas and locate sites for stacking snow.

When using skid shoes on the back of the moldboard, adjust the skids according to the surface to be plowed. The bottom of the skids should be about 1/2" below the cutting edge when plowing gravel roads or lots. Skids should be even with the cutting edge on hard surfaces such as asphalt or concrete.

Always plow snow as it is accumulating. Wet snow may weigh about 12 pounds per cubic foot. The weight of snow being pushed by your plow may increase to several tons.

Allowing snow depth to grow to unmanageable levels can cause difficult removal problems and can be costly in terms of wear on equipment.



WARNING: Serious personal injury can result from plowing at excessive speeds, as well as costly damage to equipment and property, if an obstruction is encountered while plowing. Do not exceed 10 mph while plowing.

Plow snow in the lowest truck gear to transfer maximum power to the cutting edge. Clear areas in front of buildings first. Back drag snow away from buildings by driving to the building with the plow raised, then dropping the blade to pull snow away from buildings.

Clear large lots by angling the blade and creating a single path. Roll snow to outer edges of the lot by taking successive passes with the blade angled.

When plowing very deep snow, it may be necessary to raise the blade and shear off layers of

snow until a working area is cleared. Work small areas in multiple passes to push snow to outer edges. Generally, 6 inch snow can be plowed with the entire blade width; 9 inch snow with 3/4 of the blade width; 12 inch snow with 1/2 of the blade width. Local conditions will determine how much work can be done before stalling or getting stuck.

PARKING

Lower the plow to the ground when parking your truck for a long period of time with the plow attached. Place the on/off switch in the "off" position to prevent the plow from drawing power from the truck battery. The plow's power unit may continue to draw electrical current from the truck battery if the control switch is left on; possibly resulting in insufficient charge to start the truck.

REMOVING THE PLOW

To remove the snowplow from your truck, park on a solid level surface with the blade straight across the truck. Lower the plow to the ground and leave the controller in the "float" mode.

NOTE: The plow control box must be in the "float" mode to manually retract the lift cylinder rod. If the cylinder rod cannot be retracted with power on and the controller in float, loosen the packing nut on the lift cylinder up to 1 1/2 turns to reduce friction.

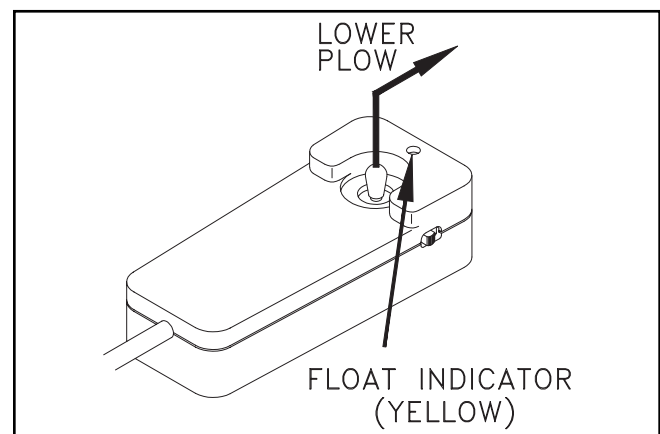

Lower Plow, Leave Controller in "Float" DWG NO. 4177

At the front of the truck, push down on the upper lift links to fully retract the lift cylinder rod. Retracting the lift cylinder will orient the prong receivers correctly for reattaching the plow later. Failure to retract the lift cylinder rod will allow

the lift frame to fall forward, possibly causing personal injury or damage to plow components.

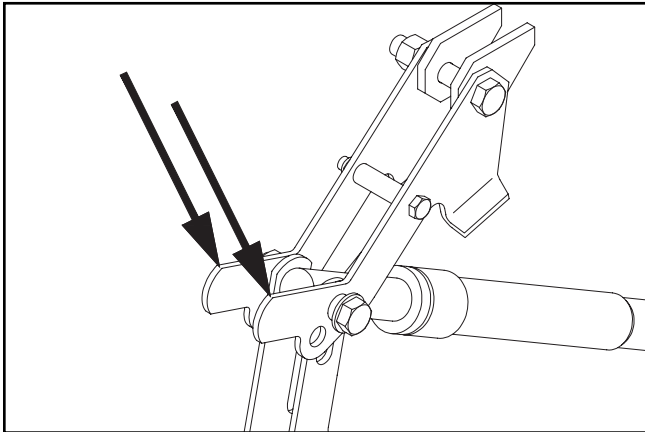

Retract Cylinder With Upper Lift Links DWG NO. 5693

Rotate the stop plate up to contact the spacer bushing on the lift cylinder bolt.

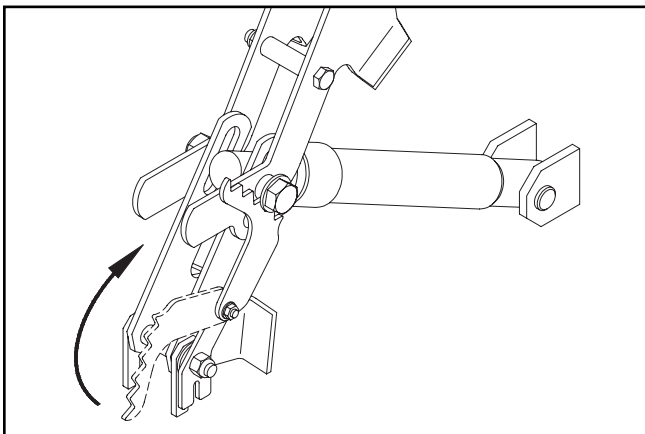

Rotate Stop Plate DWG NO. 5695

Gently push back on the headlight bracket to tilt the lift frame back as far as possible, then release the bracket to allow the weight of the lift frame to lock the stop plate in place.

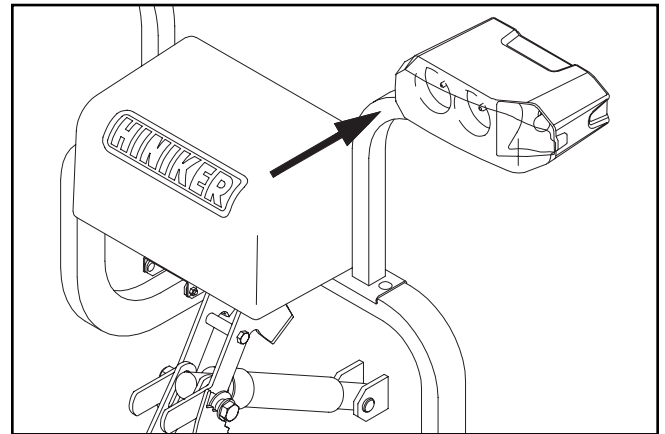

Push Lift Frame Back DWG NO. 6005A

Swing the latch handle open until the sliders are fully removed from the attachment prongs.

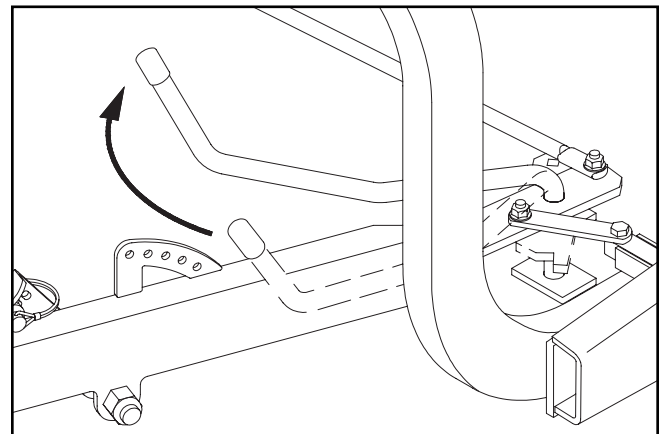

Swing Handle to Remove Sliders DWG NO. 5694

Lower the parking stand to the ground by removing the tab lock pin from the front hole in the push frame, then swinging the stand to the ground with the lever.

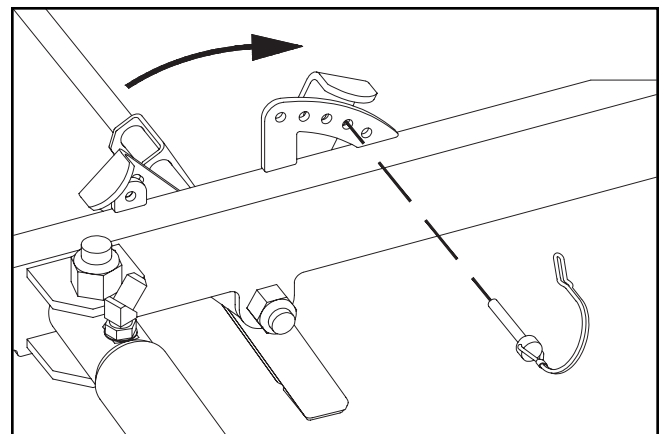

Lower and Pin Parking Stand DWG NO. 5696

Reinstall the pin through matching holes in the stand lever and push frame to hold the stand in place.

8 Operating Procedures

Disconnect the two electrical connectors by pulling them straight out from the receptacles. Do not twist the connectors. Twisting will damage the connector pins or the wiring harness.

Place dust caps on connectors to prevent contamination.

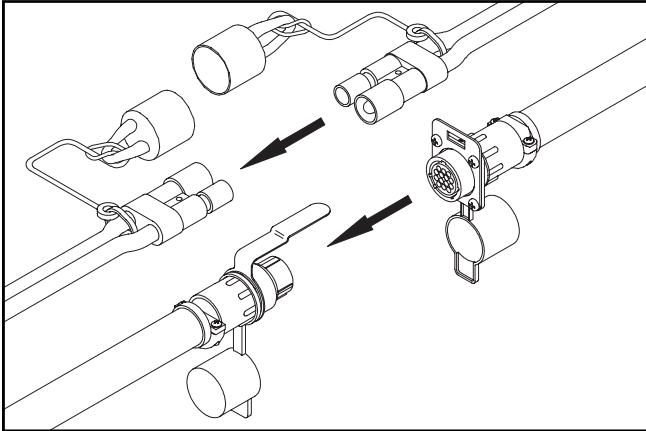

Disconnect Plugs

DWG NO. 6698

Back inside the truck, return control of the headlights to the truck and switch power off on the snowplow control box, then slowly back the truck out from the plow.

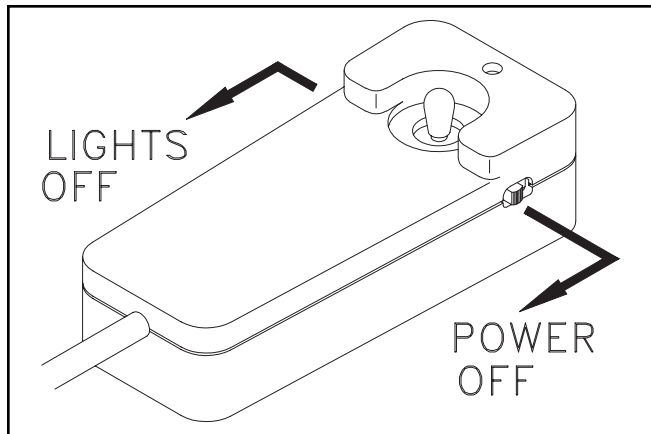

Turn Off Lights and Power

DWG NO. 4178

NOTE: The stop plate will automatically fall forward as soon as the lift cylinder is fully extended for raising the blade prior to transporting the plow.

If the snowplow won't be used for an extended period of time, the prong weldment can be removed from the truck by removing the hex bolts that fasten it to the truck mount frame.

TROUBLE SHOOTING

GENERAL

1. Check to see that the motor is wired correctly with tight connections, for the proper voltage.
2. Check reservoir oil level.
3. Check that wiring harness relay connections are wired correctly
4. Check for external leakage at cylinders, hoses and power unit.

PROBLEM	POSSIBLE CAUSE	REMEDY
1. Plow does not attach to vehicle	A. Receivers are tipped forward B. Prongs recoil out of receivers when attaching C. Park stand pinned too low	A. Fully collapse lift cylinder and rotate stop plate up to brace the lift frame before removing plow from truck B. Slowly drive into receivers and set parking brake C. Lower receivers by adjusting park stand.
2. Pump motor does not run	A. Defective solenoid B. Defective pump motor C. Weak or defective battery D. Bad electrical connections E. Defective joystick control box F. Blown fuse supplying power to control box	A. Replace solenoid B. Replace brushes or motor C. Charge or replace battery D. Clean and tighten connections E. Replace control box F. Replace fuse
3. Pump runs with joystick in neutral	A. Defective solenoid B. Defective joystick control box C. Wiring short	A. Replace solenoid B. Replace control box C. Locate and repair
4. Plow will not lower	A. Reversed wiring on valve block B. Defective joystick control box C. Defective lift return valve or coil	A. Correct wiring B. Replace control box C. Replace valve or coil
5. Hydraulic cylinder does not function or functions slowly, motor runs	A. Weak or defective truck battery B. Oil level low C. Hydraulic connection leak D. Solenoid valve not opening properly	A. Charge or replace battery B. Add oil (do not overfill) C. Tighten or redo connection D. Replace valve
6. Plow does not remain raised with joystick in "neutral" position	A. Leakage through pump check valve B. Leakage through solenoid lowering valve C. Internal leakage in cylinder D. Defective joystick control box.	A. Clean valve, or replace B. Clean valve, or replace C. Repack or replace cylinder D. Replace control Box

PROBLEM	POSSIBLE CAUSE	REMEDY
7. Angling cylinders relieve too easily or too difficultly while plowing	A. Relief pressure set too low or too high	A. Have relief pressure adjusted by Hiniker snowplow dealer
8. Oil leaks from cylinder(s)	A. Loose packing B. Defective cylinder	A. Tighten packing 1/8 turn B. Repack or replace cylinder
9. Battery goes dead with power to the control box on and joystick in neutral position.	A. Short in wiring B. Defective joystick control box	A. Locate and repair B. Replace control box
10. Battery goes dead with power to the control box off.	A. Short in wiring	A. Locate and repair
11. Plow lights are dim	A. Bad connection(s) B. Lights not properly grounded	A. Repair connection B. Properly ground
12. Plow does not clean-up snow from low areas	A. Joystick controller in neutral	A. Controller should be in the down position (float)
13. In extremely cold temperatures, the oil in the hydraulic system is thickened, causing slow functioning of the plow	A. Cold temperatures	A. As the system warms, the oil will thin out and function normally. B. Select Hiniker Cold Flow Hydraulic Oil for plowing in extremely cold temperatures.
14. Pump chatters when raising plow	A. Hydraulic oil low	A. Add hydraulic oil until chattering stops. Do not overfill.
15. Oil running out of cap on hydraulic reservoir	A. Plowing on steeply inclined terrain B. Too much oil	A. Avoid excessive inclines or change direction of plowing B. Remove excess oil
16. Vehicle overheats with the plow on	A. Vehicle coolant level low B. Ice and snow buildup in grill C. Insufficient airflow to engine compartment	A. Add coolant B. Remove ice and snow C. Transport plow at lower speeds
17. Plow lights do not operate with plow attached	A. Light switch on joystick control box in "truck" position B. Defective relay C. Faulty light switch on joystick control box D. Blown fuse on vehicle accessory feed	A. Move switch to "plow" position B. Replace relay C. Replace joystick control box D. Replace fuse
18. Truck headlights do not operate properly with plow removed	A. Light switch on joystick control box in "plow" position B. Defective relay	A. Move switch to "truck" position B. Replace relay

MAINTENANCE



WARNING: Do not service or otherwise handle a plow in the raised position unless it is securely blocked against unexpected falling.

Dependable snowplow operation is the result of following good maintenance procedures. Inspect your plow frequently to ensure that all parts are working smoothly, and develop a schedule for maintenance at required intervals.

GENERAL

Wash salt and dirt off the plow before storage. Do not power wash hydraulic cylinders, as high pressure can damage seals and cause cylinder failure. Touch-up any chips or scratches in the paint and apply a light coating of grease to extended cylinder rods to prevent corrosion.

HYDRAULIC SYSTEM

The majority of snowplow operational problems are caused by bad oil in the hydraulic system. Hydraulic oil should be changed every year for best performance. Select Hiniker Cold Flow Hydraulic Oil, or an equivalent oil that meets military specification 5606, for plowing in extremely cold temperatures.

To change hydraulic oil, disconnect the electrical wiring harnesses from the snowplow power unit and uncouple three hydraulic lines. Unbolt the power unit from the plow, and remove it to a clean working area that can capture any spilled oil.

Carefully unbolt the oil reservoir from the power unit and discard old oil. Purge old oil from the angling cylinders by forcing rods to retract.

Clean the suction filter at the pump inlet and wipe any metal shavings off the magnet on the pump.

Re-attach the reservoir onto the power unit and re-connect the power unit on the snowplow before adding new hydraulic oil.

Re-attach hydraulic hoses and electrical wires at the correct locations on the power unit.

Pour hydraulic oil into the power unit reservoir until the reservoir is half full. Angle the plow full left or right to fill the angling cylinder with oil, then add more oil until the reservoir is about 3/4 full. Do not overfill the oil reservoir.

Cycle the plow left and right and up and down to purge any air trapped in the hydraulic system.

Check the oil level with the plow on the ground. Add oil to the fill line, if necessary, but do not over fill the reservoir.

ELECTRICAL MAINTENANCE

Periodically check all electrical connections for proper fit and remove any contamination that may be present.

To prevent contamination always place dust caps on connectors when not in use. This is particularly important when the plow is being stored. The use of dielectric grease is recommended to reduce corrosion of the contacts and to make connecting and disconnecting easier.

Before each season check the vehicle battery and electrical system for proper operation. A weak battery, dirty terminals, or faulty charging system may cause improper operation and possible failure of the joystick controller.

Before every plowing season, and throughout the season, check the snowplow headlamps for proper function and aim. Refer to sections titled "System Check-Out" and "Headlamp Aiming Procedure" in this manual for instructions.

MECHANICAL COMPONENTS

Prior to the operation of a new snowplow, or one which has been stored, inspect all hardware and verify proper torque on all bolts and nuts in accordance with the recommended torque specifications.

GRADE 5 TYPE B & F LOCK NUT TORQUE VALUES

Size	Ft-lbs.	N-m
5/16"	13-18	17-25
3/8"	23-33	31-44
1/2"	58-82	79-112
5/8"	117-165	158-223

GRADE 5 BOLT TORQUE VALUES*

Size	Ft-lbs.	N-m
1/4"	8-12	11-16
3/8"	29-41	39-56
1/2"	73-103	99-140
5/8"	146-206	198-279

*applications without lock nuts.

Loose bolts can cause hole elongation and part failure resulting in dangerous operating conditions and equipment breakdown.

Check all hardware periodically during operation and keep tightened to specified torque value.

Replace worn bolts and lock nuts with grade 5 bolts and equivalent type B or type F lock nuts. Type B lock nuts are plain hex; type F lock nuts are flanged hex.

Inspect wear of the cutting edge before every plowing season and frequently throughout the season. Replace the cutting edge before wear reaches the main plow blade.

Once a year before using the plow, check that the moldboard will trip freely about the pivot tube. With the snowplow mounted on the truck and the cutting edge on the ground, unfasten the extension springs on the back of the moldboard by loosening the 5/8" lock nuts on the threaded spring studs, then pull the top of the moldboard fully forward.

If the blade does not trip freely, oil the pivot tube at the four locations where it passes through ribs on the back of the moldboard.

Damage to the snowplow or the truck may result if the moldboard hits an obstruction during use and doesn't trip.

Reassemble the two trip springs between lugs on the pivot tube and channels along the upper edge of the blade. Tighten the two lock nuts until spring coils begin to separate.

The 5/16" hex bolts in the latch sliders are factory retained with anaerobic threadlock. If removal or replacement of these bolts is necessary, purchase new bolts with threadlocker from your Hiniker dealer, or apply a commercially available threadlock, i.e., Loctite 242 (blue) or Perma-Lok HM118 (red), to standard 5/16-18 X 3/4" grade 5 hex bolts before reassembly.

PLOW ASSEMBLY

GENERAL INFORMATION



WARNING: To prevent personal injury or death, be certain to keep clear of any parts that may drop when removing bundling straps, wires or brackets. Support heavy sections with hoist or blocks before removing wires or straps.

In the following instructions, left and right machine references are defined as being viewed from the cab of the truck. Be certain that hydraulic hoses and electrical wires are safely routed and allow full motion of moving parts. Secure loose wires with plastic tie straps. Some components are fastened at incorrect locations for shipping purposes.

All hardware should be tightened only enough to ensure safety during assembly. Torque hardware to specified values, as shown in the following chart, only after assembly has been completed.

GRADE 5 TYPE B & F LOCK NUT TORQUE VALUES

Size	Ft-lbs.	N-m
5/16"	13-18	17-25
3/8"	23-33	31-44
1/2"	58-82	79-112
5/8"	117-165	158-223

GRADE 5 BOLT TORQUE VALUES*

Size	Ft-lbs.	N-m
1/4"	8-12	11-16
3/8"	29-41	39-56
1/2"	73-103	99-140
5/8"	146-206	198-279

* applications without lock nuts

Replace worn bolts and lock nuts with grade 5 bolts and equivalent type B and type F lock nuts. Type B lock nuts are plain hex; type F lock nuts are flanged hex.

PLOW ASSEMBLY

1. Place moldboard face down on cardboard or other padding that will prevent scratches in the paint.

Remove two side markers and four shipping brackets from the ends of the moldboard. Save the bolts and nuts for reinstalling markers later.

Open the frame crate and set aside the power unit box and head lamp boxes for later assembly.

Locate the hardware bag inside the parts box and remove two 3/4 inch x 3 inch clevis pins and two cotter pins from inside the bag for attaching the hydraulic cylinder rods to the back of the moldboard.

Remove the 3/4 inch x 4 1/4 inch hex bolt from between the hitch plates on the front of the push frame weldment and save for reassembly.

Snip the plastic tie straps holding the hydraulic cylinders to the push frame and rotate cylinders forward.

Carefully lift the frame assembly by wrapping straps or padded chains around both ends of the 2 1/2 inch square tube at the rear of the frame assembly.

Fasten the frame assembly to the moldboard assembly by lining up holes in the push frame hitch plates with the reinforced center hole through the pivot tube on the back of the plow blade.

14 Plow Assembly

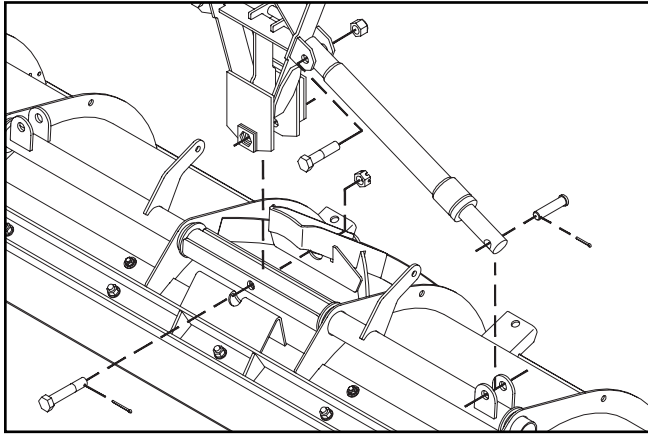

DWG NO. 5698B

Install the 3/4 inch x 4 1/4 inch hex bolt removed earlier so the bolt head is retained by the lock plate on the push frame. Secure the assembly with the 3/4 inch slotted nut and cotter pin so the plow blade is free to pivot.

Use clevis pins and cotter pins to fasten the hydraulic cylinder rods between lugs on the moldboard. Cylinder ports should be directed up.

2. From the parts box, remove two extension springs.

Inside the hardware bag, find two threaded spring studs and two 5/8 inch nylon insert lock nuts.

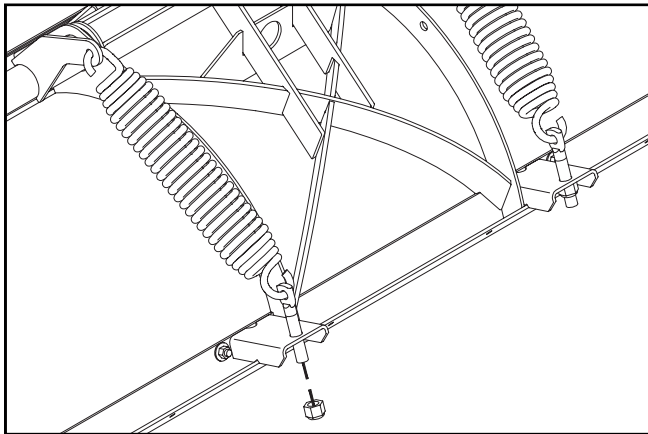

DWG NO. 5692A

Slide a spring stud onto each spring, then assemble springs between lugs on the moldboard pivot tube and channels along the upper edge of the blade.

Tighten lock nuts until spring coils begin to separate.

3. Gently tip the plow assembly to its working position with a hoist or forklift. Pin the parking stand to hold the push frame parallel to the ground.

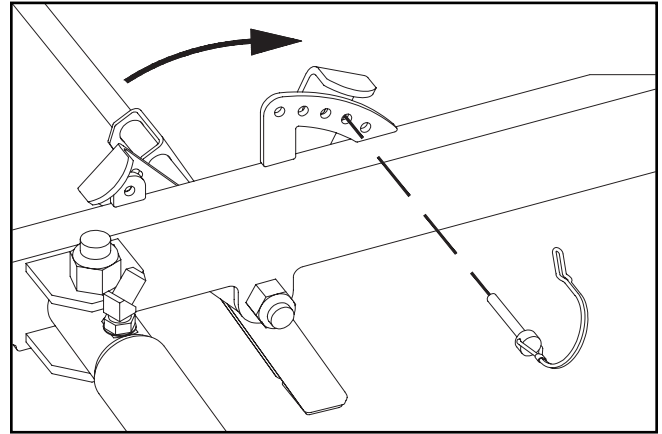

DWG NO. 5696

Swing the lift frame up to its approximate working position and hold with a hoist or forklift for installation of the lift cylinder.

The bottom surface inside the two prong receiver channels should measure about 10 inches above the ground in the working position.

4. Locate the 90° O-ring/flange adapter in the hardware bag from the parts box.

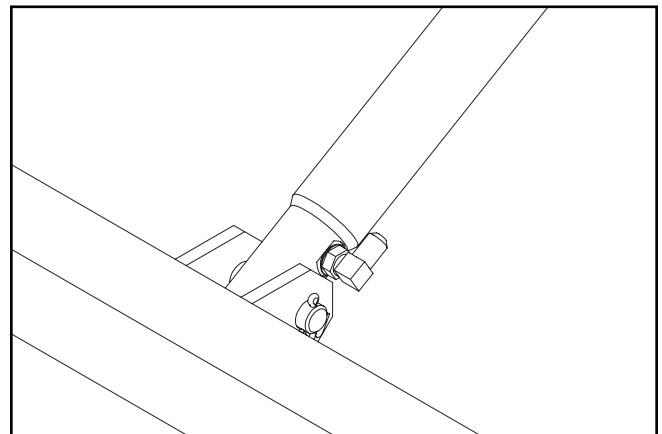

DWG NO. 5699

Install the O-ring end of the 90° fitting into the lift cylinder port so that the flared end points toward the rod end when tightened.

Pin the lower end of the lift cylinder between the lugs on the frame assembly with the hardware provided. The 90° adapter should be on the RH side of the cylinder.

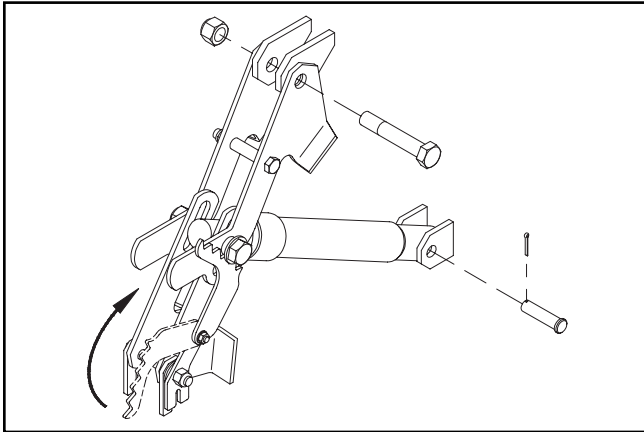

DWG NO. 5700

Rotate the stop plate assembled to the push frame up to contact the spacer bushing on the lift cylinder bolt. Gently push back on the upper lift frame tube, then release to allow the weight of the frame to lock the stop plate in place.

- Before assembling the power unit on the lift frame, scrape a small amount of paint from the two mount holes in the lift frame to provide a good electrical ground for the turn signals and parking lights.

Mount the power unit on the lift frame with two 3/8" x 3/4" hex bolts and two 3/8" lock washers. The plastic reservoir of the power unit should be to the left side of the plow.

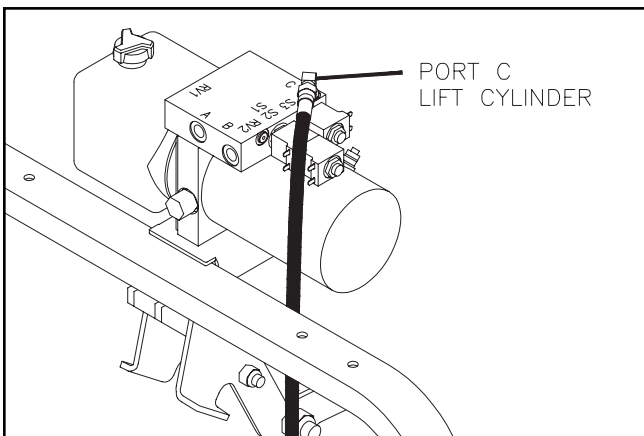

DWG NO. 6484A

Locate three 90° O-ring/flare adapters in the hardware bag.

Turn the O-ring end of one adapter into the top port of the power unit so that it points about 45° to the right and to the rear when viewed from the top.

Turn the other two 90° adapters into ports A and B from the back of the power unit so that the flare ends point straight down.

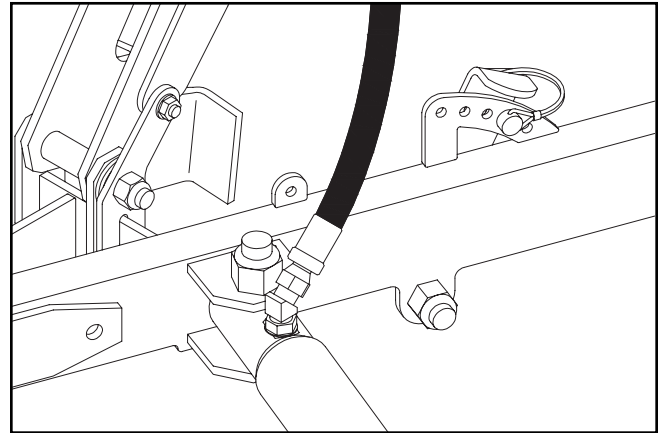

DWG NO. 5702A

Install 45° O-ring/flare adapters into the ports of the angling cylinders so that the flare ends of the adapters are directed straight back.

Three identical hydraulic hoses are in the parts box. Each hose has a swivel nut on each end that will assemble to the adapters from the power unit and three cylinders.

Connect one hose to the fitting from the top of the power unit, then route the hose ahead of the lift frame tube before assembling to the fitting from the lift cylinder.

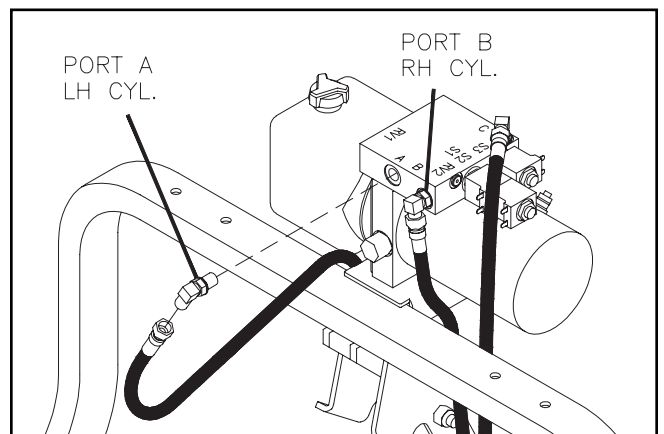

DWG NO. 6485A

Connect the remaining two hoses to the fittings from ports A and B at the back of the power unit. Route both hoses ahead of the lift frame tube before assembling the hose from port A to the LH side angling cylinder and the hose from port B to the RH side angling cylinder.

The fitting in the LH side angling cylinder may have to be adjusted slightly to route the hydraulic hose to best avoid interference with the latch handle and the lift links. Use plastic tie straps to secure all hydraulic hoses away from lift link stops.

- Before assembling the headlamp brackets on the lift frame tube, scrape a small amount of paint from the three holes in each bracket and from the four holes in the frame tube to provide a good electrical ground for the turn signals and parking lights.

Mount the headlamp brackets to the lift frame tube with four 3/8 inch x 2 inch carriage bolts and flanged lock nuts from the hardware bag in the parts box.

Remove the LH and RH headlamps from their boxes and mount on the brackets with hardware from the headlamp boxes.

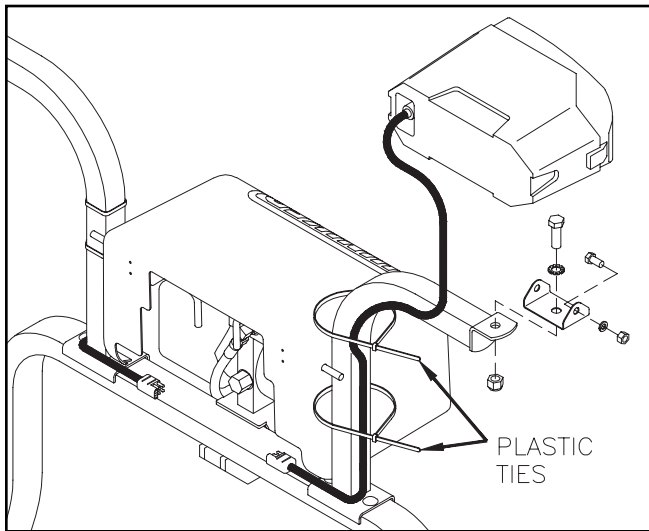

DWG NO. 7218

Use plastic tie straps to band headlamp cables above and below the brackets at the locations shown to provide clearance for the power unit cover later.

Refer to sections titled "System Check-Out" and "Headlamp Aiming Procedure" in this manual for aiming instructions.

- Identify the plow power cable assembly and plow wiring harness in the parts box. A ground wire harness for the solenoids is in the power unit box.

The power cable for the snowplow has two cables with ring terminals on one end and a

two pin connector on the other and measures about 38" long.

The plow wiring harness has a 16-pin connector on one end and the other end has connectors labeled "DRIVER SIDE" and "PSNGR SIDE" for the headlamps and three loose wires with spade terminals.

The ground wire for the solenoid has one wire 7 inches long and two wires 11 inches long. There is a 1/4 inch ring terminal on the common end and three spade receptacles on the remaining ends.

NOTE: To prevent corrosion lightly coat all electrical connections, ring and spade terminals with dielectric grease prior to assembly.

Refer to drawing 6502. Attach the ring terminal of the solid red (or red-striped) wire of the power cable assembly to the terminal on the power unit at location 1.

Fasten the ring terminal of the solid black wire of the power cable assembly and the ring terminal of the solenoid ground harness to the terminal on the motor at location 2.

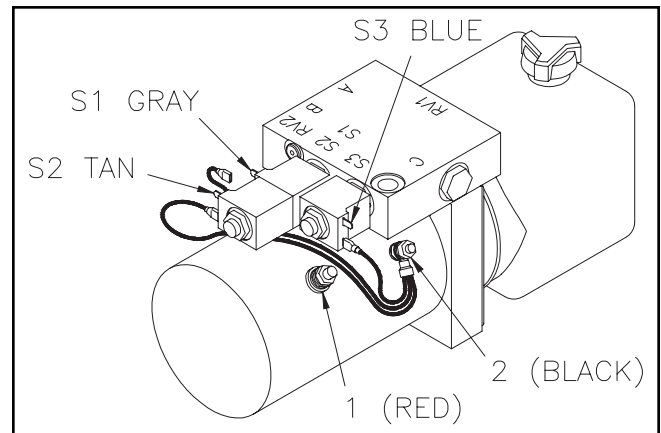

DWG NO. 6502A

Connect the three black wires of the ground harness to solenoids S1, S2 and S3.

Connect the gray wire from the wiring harness to solenoid S1. S1 extends the right side of the plow to plow left.

Connect the tan wire from the wiring harness to solenoid S2. S2 extends the left side of the plow to plow right.

Connect the blue wire from the wiring harness to solenoid S3. S3 lowers the plow.

Connect the RH headlamp to the wiring harness end labeled "PSNGR SIDE" and the LH headlamp to the end labeled "DRIVER SIDE".

Ensure connections are fully mated for proper sealing. There should be no gaps between connector halves. Secure these cables to the frame with plastic ties.

NOTE: Install the plow harness so that water does not run down the wires and pool inside the "Y" connection. Position the harness so that any trapped water can easily drain away.

WARNING: Disconnect truck battery before beginning electrical installation to avoid shock hazard.

8. The motor solenoid, underhood wiring harness, power cable and joystick control box are located in the parts box shipped with the snowplow frame.

NOTE: To prevent corrosion lightly coat all electrical connections, ring and spade terminals with dielectric grease prior to assembly.

Refer to drawing 6699. Lay the underhood harness in it's approximate position for final assembly with the 7-pin circular connector near the driver's side firewall. Place the 16-pin connector just left of center near the grill, the set of four relays near the driver's side inner fender and the other set near the passenger side inner fender. Place the 5-pin headlight connectors at the respective head lights.

9. Determine the location of the vehicle battery. If the battery is located on the right (passenger) side or if there are two batteries configured as a 12 volt system then proceed to step 10. If the battery is located on the left side of the vehicle then the wiring harness will need to be modified.

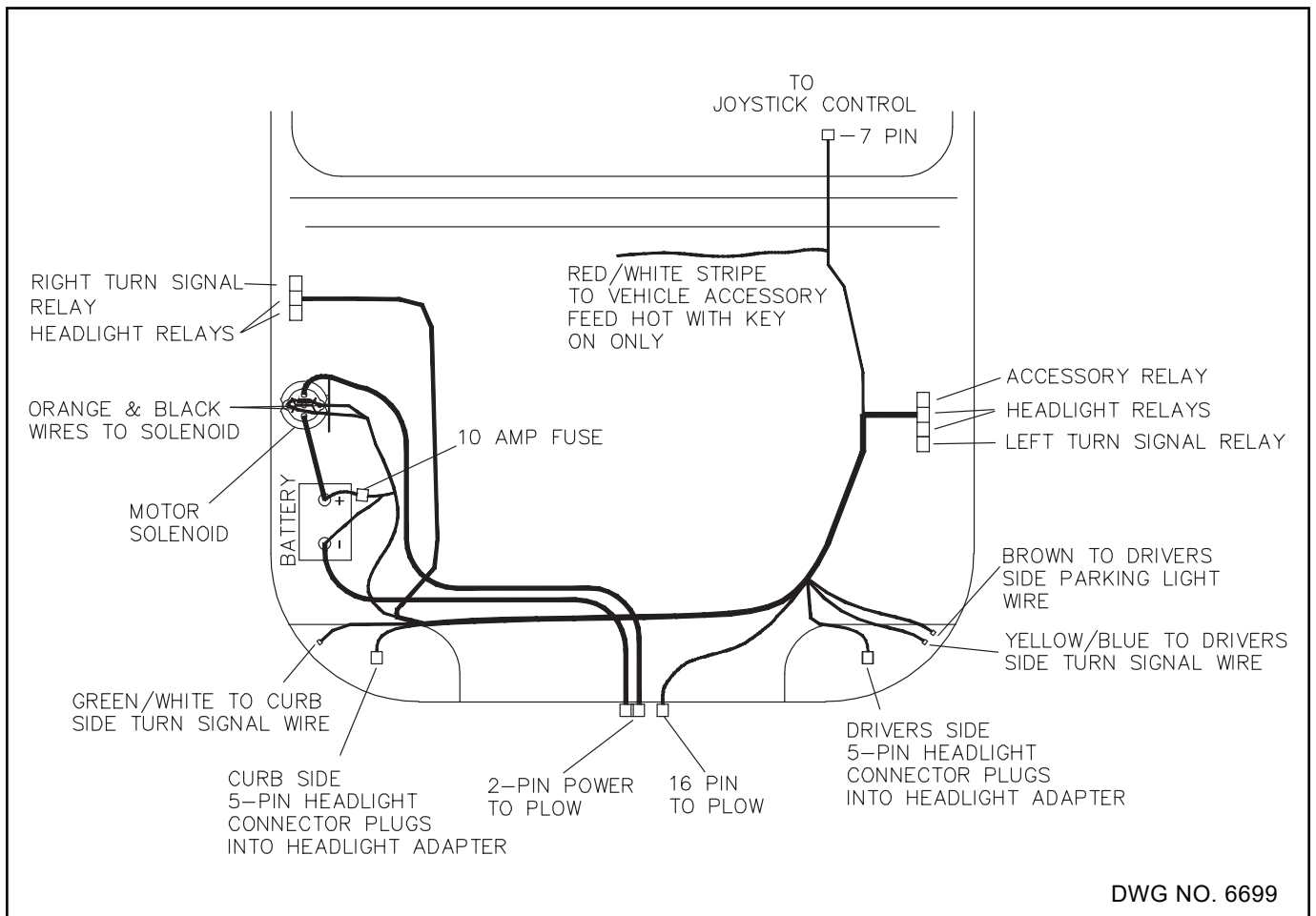

DWG NO. 6699

Truck Battery On Passenger Side

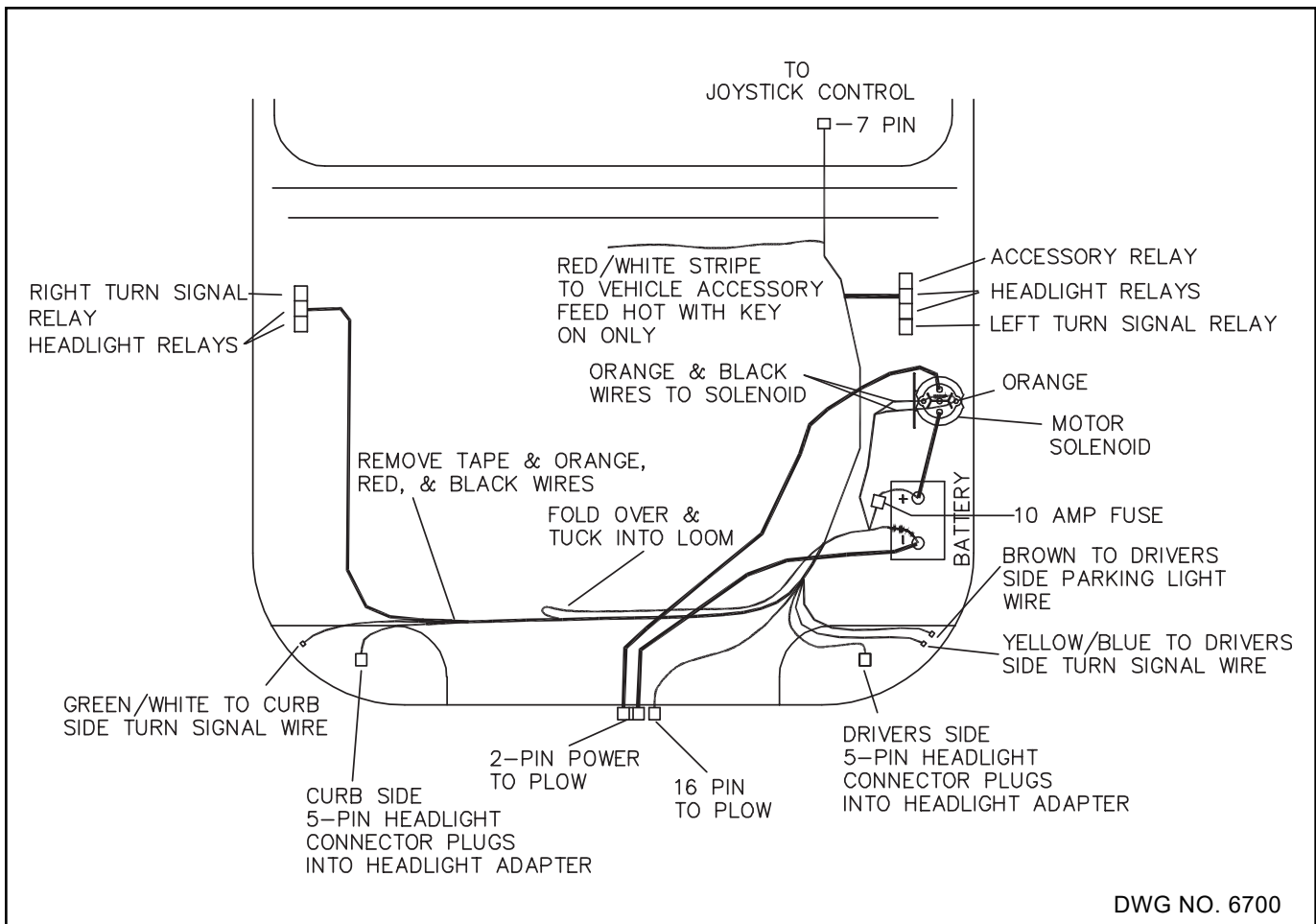

Truck Battery On Driver Side

Refer to drawing 6700. Remove the tape from the black corrugated loom at the points shown. Locate an Orange, Red, and two Black wires. These wires connect to the battery and motor solenoid. Remove the four wires from approximately 33 inches of the loom, making sure the Red and Black wires are long enough to connect to the battery. Tuck these wires back into the loom as shown in the drawing and retape the loom.

10. If there is no access hole in the drivers side firewall then drill a 1-1/8 inch diameter hole. Route the 7-pin circular connector through the firewall into the cab compartment and install the 4 inch grommet in the hole, if required.

11. Select an area near the driver's side inner fender to mount the four relay set. Drill two 1/8" diameter holes and secure the relays using #8 x 1 1/2" self-tapping screws from the hardware bag in the parts box. Apply a light coat of dielectric grease on the relays before inserting into holders.

NOTE: Always mount the relays with the wires pointing down to prevent contamination.

Repeat this procedure and mount the three relay set on the passenger side inner fender.

12. Splice the red with white stripe wire to the vehicle's switched 12 volt auxiliary electrical circuit. This will prevent operation of the plow without the vehicle key being on. This wire controls the accessory relay that powers the control joystick and solenoids.



CAUTION: Ensure that the relays will clear any hood lift/spring mechanisms before installation.

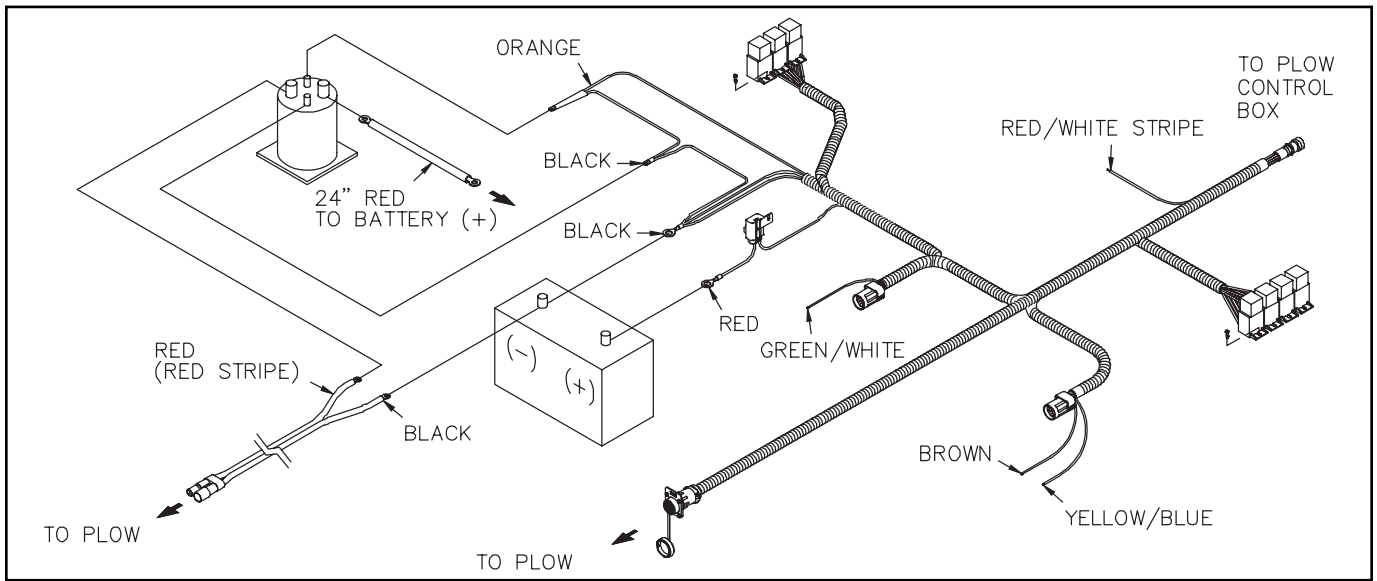

DWG NO. 6701

CAUTION: To prevent injury or property damage caused by unintentional plow movement when the key is removed from the vehicle, the red/white striped wire must be connected to a switched power source on the vehicle. Connecting to a power source not controlled by the ignition switch will allow movement of the plow with the vehicle key removed.

13. Connect the joystick control box to the 7-pin connector inside the truck cab. Secure the box at a safe location in the cab with the strip of hook and loop fastener.

WARNING: Ensure that the motor solenoid and associated wiring will clear any hood lift/spring mechanisms before installation.

IMPORTANT: Do not over tighten nuts on the motor solenoid terminals. Over-tightening causes premature solenoid failure. Refer to torque specifications on the solenoid.

14. Select an area within 16 inches of the vehicle battery for the motor solenoid. Using the solenoid as a template, mark then drill two 3/16" diameter holes and fasten the solenoid with two 1/4 inch x 1/2 inch long self tapping screws from the hardware bag in the parts box.

Connect the Black wire to one of the small posts on the solenoid, connect the Orange wire to the remaining small post, polarity is not important.

15. Safely route the 16-pin circular connector through the grill of the vehicle to a location that will be easily accessible with the plow attached.
16. Refer to drawing 6701. Install the underhood power cable by first connecting the Black cable and the three Black wires from the harness to the minus (-) post of the vehicle's battery. Connect the Red (or Red striped) cable to the motor solenoid. Route the power cable to the grill near the 16-pin connector.

Connect the Red fused wire from the harness and the 24 inch Red cable to the plus (+) terminal of the battery or battery access post. Connect the other end of the 24 inch Red cable to the motor solenoid.

17. Locate three blue connector splices in the hardware bag in the plow's parts box.

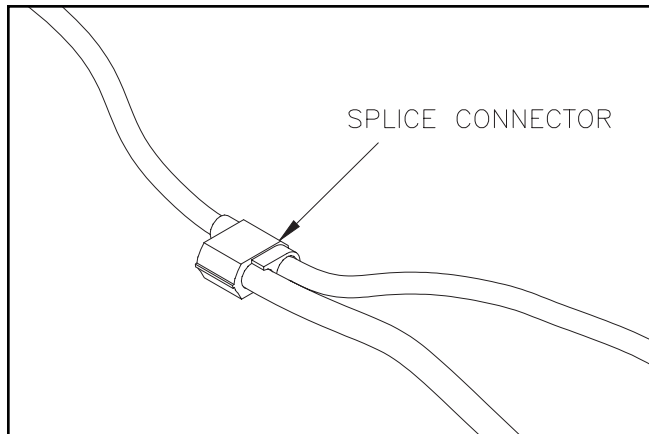

DWG NO. 4165

Using a blue splice, crimp the single brown wire from the underhood harness into the vehicle's driver's side parking light wire.

Using a blue splice, crimp the single yellow wire from the underhood harness into the vehicle's driver's side turn signal wire.

Using a blue splice, crimp the single green wire from the underhood harness into the vehicle's curbside turn signal wire.

18. Select the proper headlight adapter for your vehicle, specific instructions are included with each kit.

The headlight adapter kit consists of two identical adapters. Install the adapters according to the instructions included with the kit and connect to the 5-pin connectors of the underhood wiring harness.

19. Secure all cables away from hot or moving components with cable ties.

This completes the Electrical Installation.

20. At this point, the mount kit should be assembled onto the truck.

Prongs from the truck mount kit should be at a height that will slightly lift the plow frame when attaching the plow. Prong receivers on the plow frame should be parallel to the ground when attaching the plow. Apply powered graphite on the truck prongs to help the plow to slide on and off more easily.

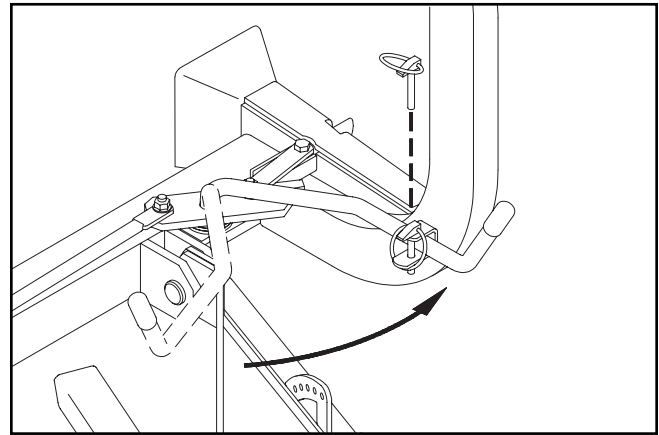

Handle Pinned With Plow on Truck DWG NO. 5691

Attach the plow onto the truck by driving the truck prongs into the receivers on the plow frame. Pull the latch handle into the frame clevis to move sliders through the notches in the prongs and receivers. Pin the handle in the clevis with its klik pin.

Raise the parking stand to its highest position and repin.

Connect the two electrical cables from the plow to their corresponding receptacles on the truck.

Select Hiniker Cold Flow Hydraulic Oil, or an equivalent oil that meets military specification 5606, for plowing in extremely cold temperatures.

Pour hydraulic oil into the power unit oil reservoir until the reservoir is half full.

Angle the plow full left or right with the cab control box inside the truck to fill the angling cylinder with oil. Add more oil until the reservoir is about 3/4 full. Do not over-fill the reservoir.

Cycle the plow left and right and up and down to purge any air trapped in the hydraulic system.

Check the oil level with the plow on the ground. Add oil to the fill line, if necessary, but do not overfill the reservoir.

NOTE: New hydraulic cylinders will leak a small amount of oil until packings become saturated and produce a good seal. If leakage is excessive, or if leaking continues after initial cycling, tighten the cylinder packing nut in 1/8-turn increments until leaking stops.

21. Fasten the power unit cover onto the lift frame bracket with two 1/4" x 3/4" screws, flat washers and lock nuts from the hardware bag in the parts box. Tighten the lock nuts so that the assembly is secure, yet the cover hinges freely.

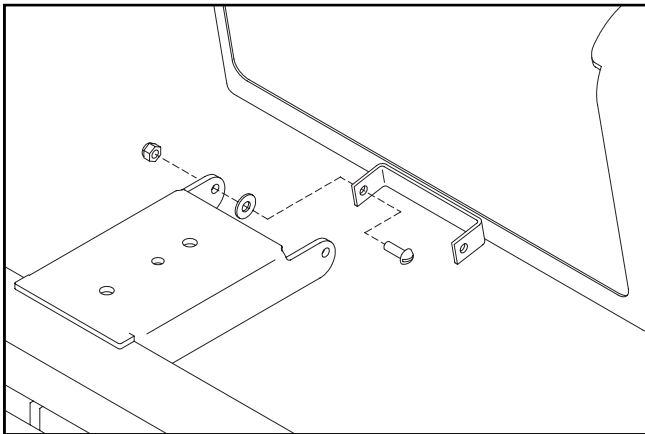

DWG NO. 6310

When the cover is closed, rods from the latch handles should extend behind the light brackets to hold the cover in place.

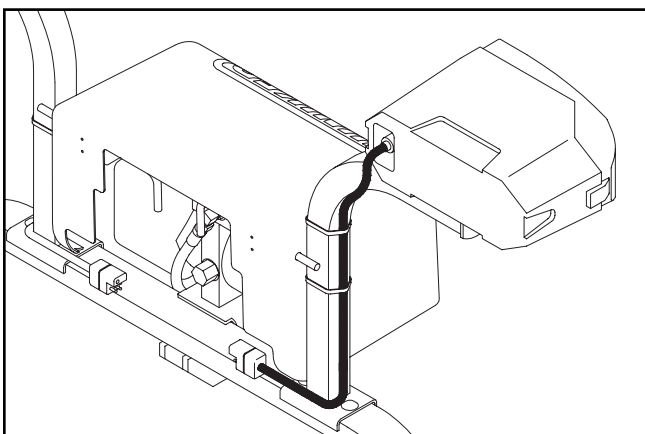

DWG NO. 7219

22. Assemble side markers on the ends of the moldboard with 5/16 inch bolts, flat washers and lock nuts.

SYSTEM CHECK-OUT

NOTE: The power cable and wiring harness must be connected between the snowplow and truck to test the functions of the headlights and power unit. Vehicle ignition must be switched on.

1. Move the headlight switch on the joystick controller to the "TRUCK" position and turn on the vehicle headlights. High and low beams should operate on the truck.
2. Move the switch to the "PLOW" position. Plow lights should operate in both high and low beams. Vehicle headlights should be off.
3. Test the parking lights and turn signals. Lights on the plow and truck should operate at the same time.
4. In an area clear of bystanders, test joystick functions by raising and lowering the plow and angling side to side.

To reverse the angle functions, exchange the tan and gray wires on the power unit.

Raise and lower functions may be reversed, as follows.

JOYSTICK CONFIGURATION

As supplied from the factory, the snowplow controller raises the plow when the joystick is pulled

backward and lowers the plow when the joystick is pushed forward. These functions can be reversed by reassembling the joystick switch and face plate.

To reverse the face plate, pry the plate away from the controller by inserting a small screwdriver along the side of the plate at location 1 in drawing 5722. Flip the plate over, then reinstall by gently squeezing the long sides together and sliding the four tabs into slots in the controller top.

To reverse the joystick switch, remove four screws from the back of the controller and remove the main circuit board assembly from the case halves.

Gently pull on the edges of the small circuit board at the base of the joystick switch to remove the switch from the five pins on the main circuit board.

Rotate the switch 90°, then gently push the switch back onto the five pins.

Insert the main circuit board assembly back into the case top, making sure the joystick is properly seated and the harness strain relief is inside the case.

Reassemble the case with the four screws, checking that wires are not pinched between bosses.

Test the controller on the snowplow or a plow tester to verify that raise and lower functions match arrows on the face plate.

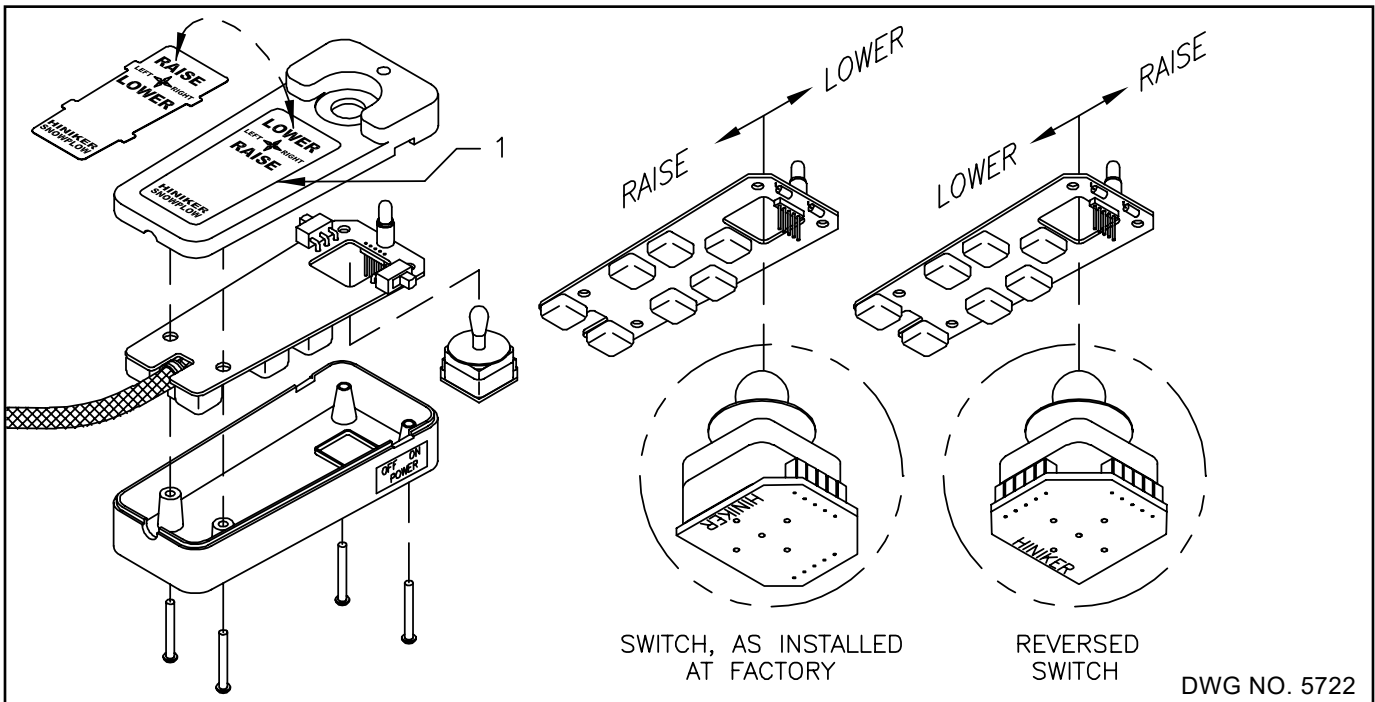

DWG NO. 5722

HEADLAMP AIMING PROCEDURE

1. Park the vehicle with the plow attached on a level surface 25 ft (7.6 m) from a flat, unobstructed light-colored wall.

With no load on the vehicle other than the driver, snowplow and rear ballast weight, inspect the vehicle for proper tire inflation and broken or sagging suspension components. Check functioning of any automatic vehicle leveling systems and any specific manufacturer's instructions pertaining to vehicle preparation for headlamp aiming. Stabilize the suspension by rocking the vehicle sideways.

2. Mark a vertical line (line 1) on the wall with black tape, or other means, directly ahead of the center of the vehicle.

Mark two additional vertical lines (lines 3 and 4) offset 20 1/2 inches (52 cm) from the first line representing the distance between the two plow headlamps.

3. Measure the height from the ground to the center of the plow headlamps, then mark a horizontal line (line 2) on the wall at that same height.

4. Refer to the following chart then mark a second horizontal line below the first (line 5), as required.

Headlamp Centerline Height	Vertical Aim Down
22 to 36 in (56 to 90 cm)	0
36 to 48 in (90 to 120 cm)	2 in (5 cm) Down
48 to 54 in (120 to 140 cm)	4 in (6.4 cm) Down

5. Wipe the lamp lenses clean and check for proper switching and function.

Activate the plow lamp HIGH beams to illuminate toward the wall. Focus the center of the LH light beam on the intersection of lines 3 and 5. Focus the center of the RH light beam on the intersection of lines 4 and 5.

Tighten the headlamp mounting hardware to 70 ft.-lbs. (95 N-m) maximum to hold the headlamps in position.

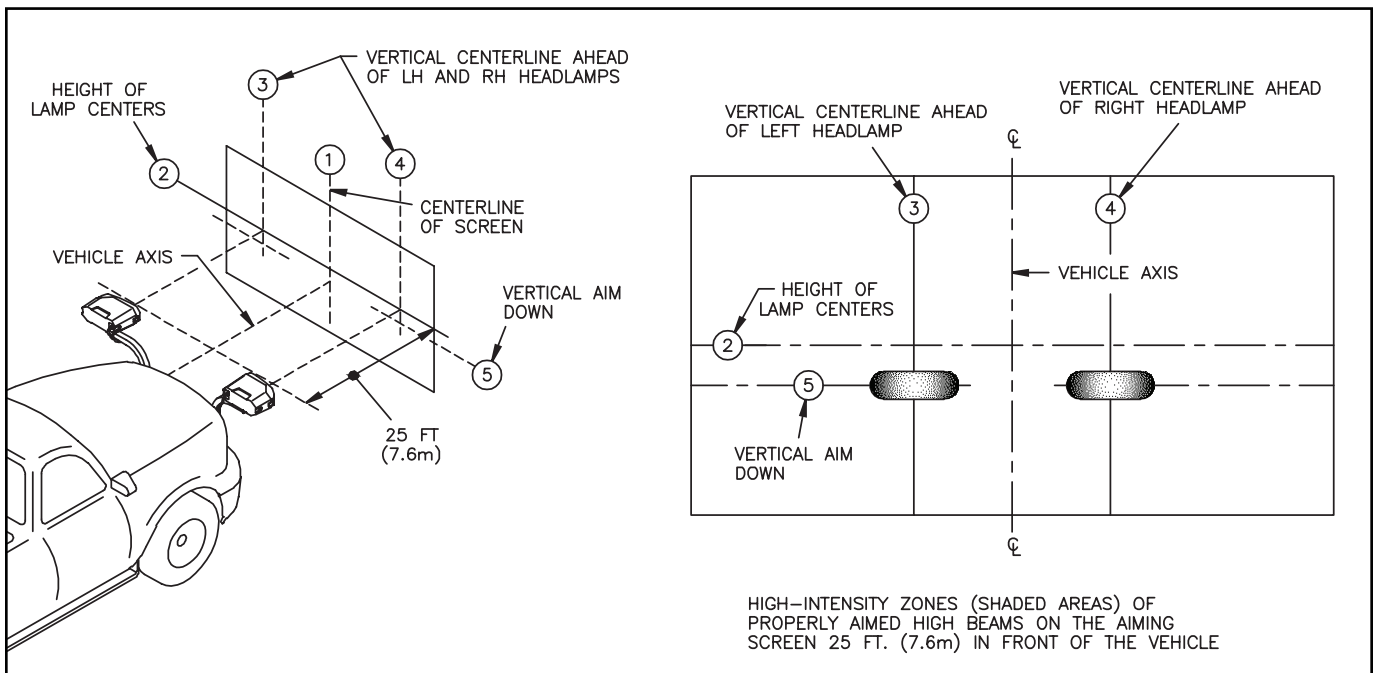

CAB CONTROL

J1

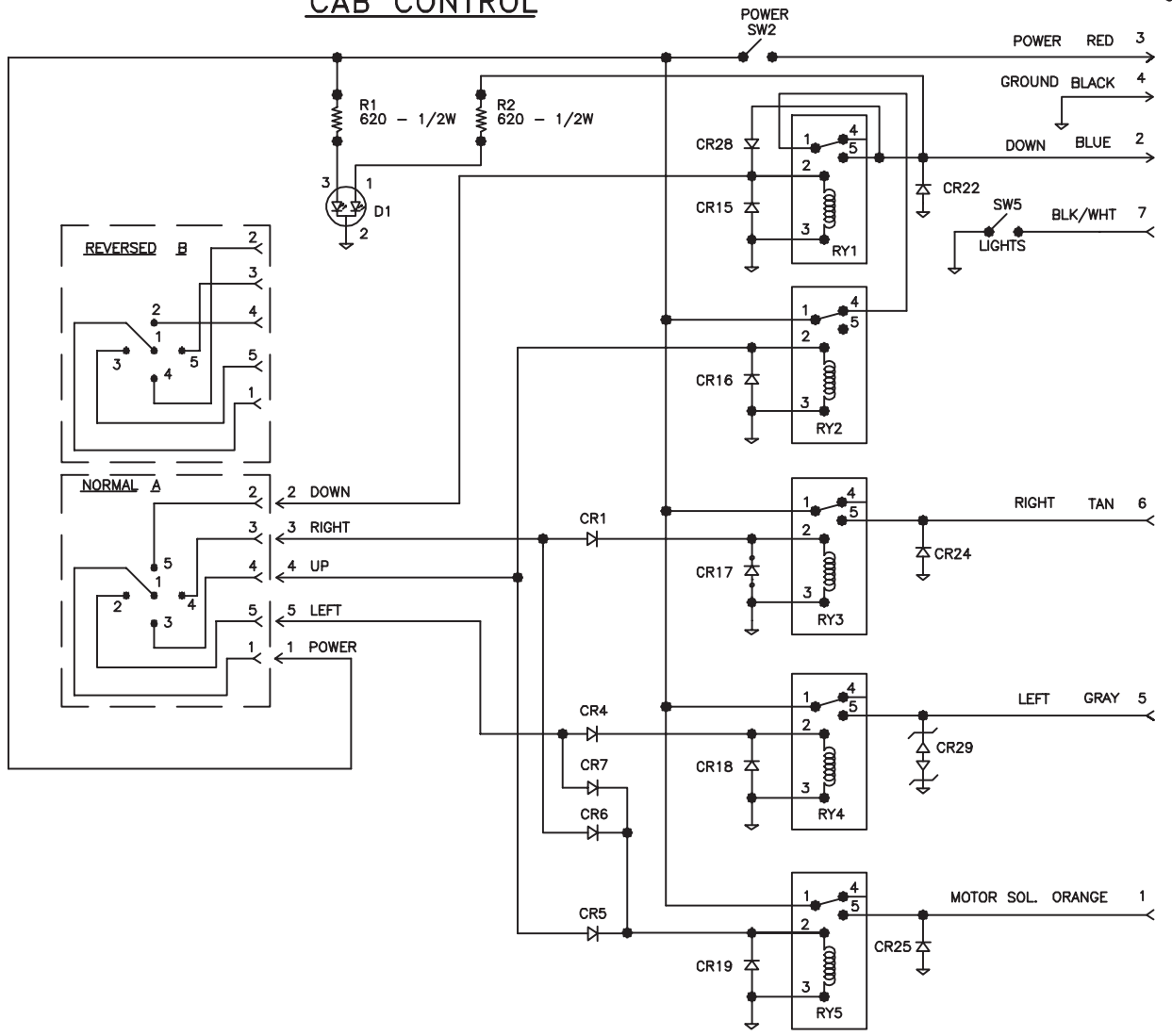

P1 **UNDERHOOD HARNESS** **EXTERNAL HARNESS**

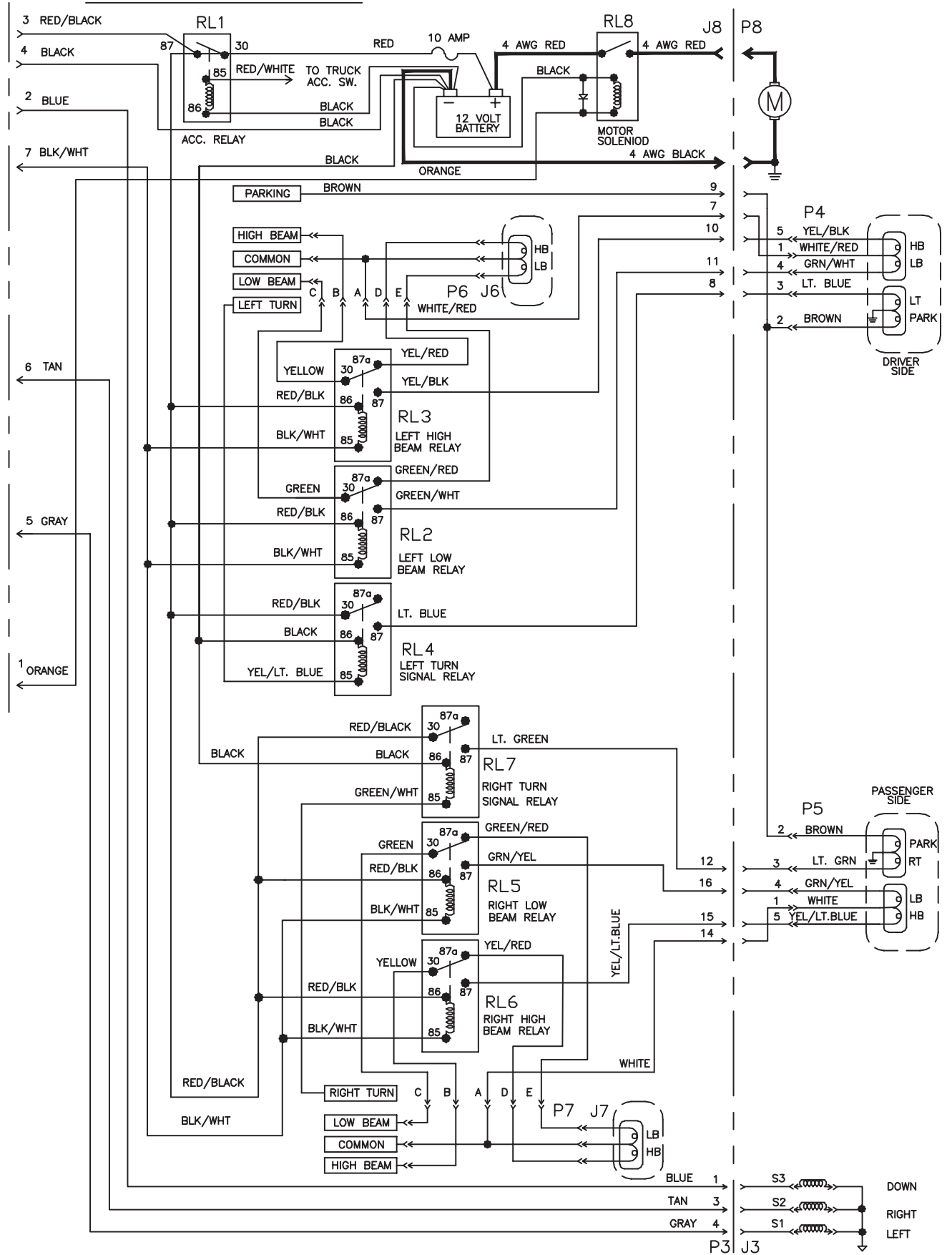

STRAIGHT PLOW POWER UNIT - SPX

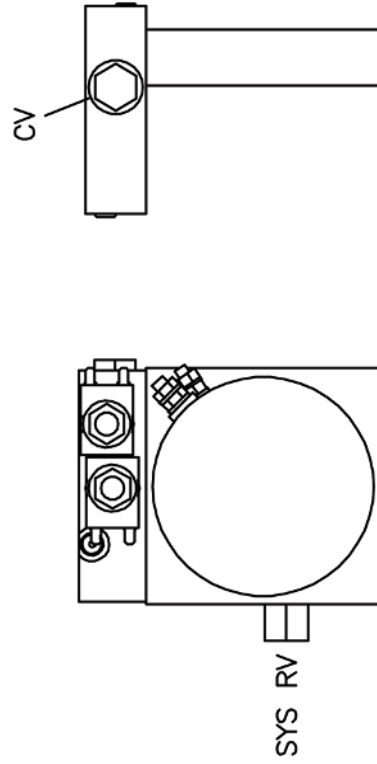
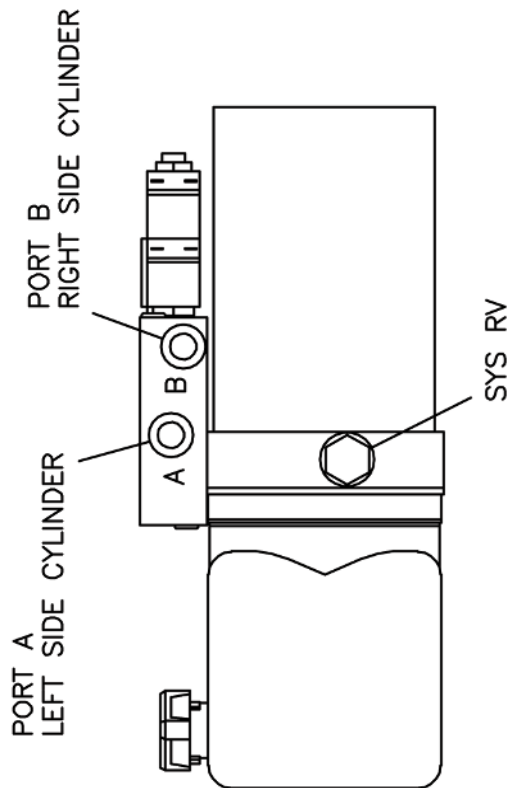
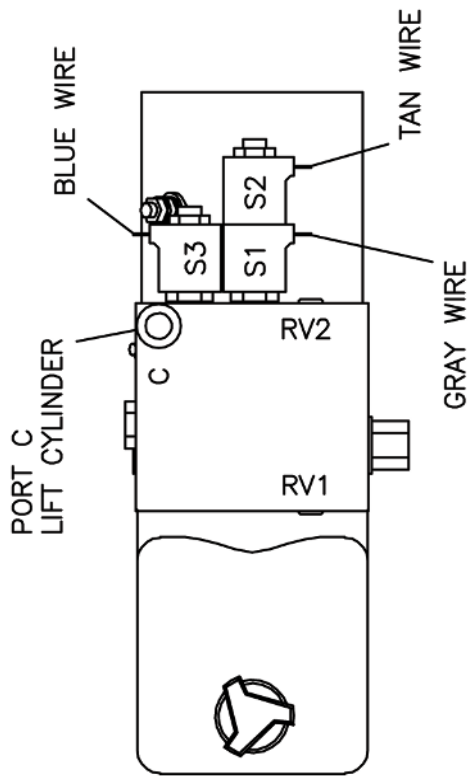

RV1 - RELIEF VALVE, RIGHT SIDE CYLINDER, 2100 PSI
RV2 - RELIEF VALVE, LEFT SIDE CYLINDER, 2100 PSI
SYSRV - RELIEF VALVE, SYSTEM, 2000 PSI

POWER UNIT HYDRAULIC CIRCUIT DIAGRAM - SPX

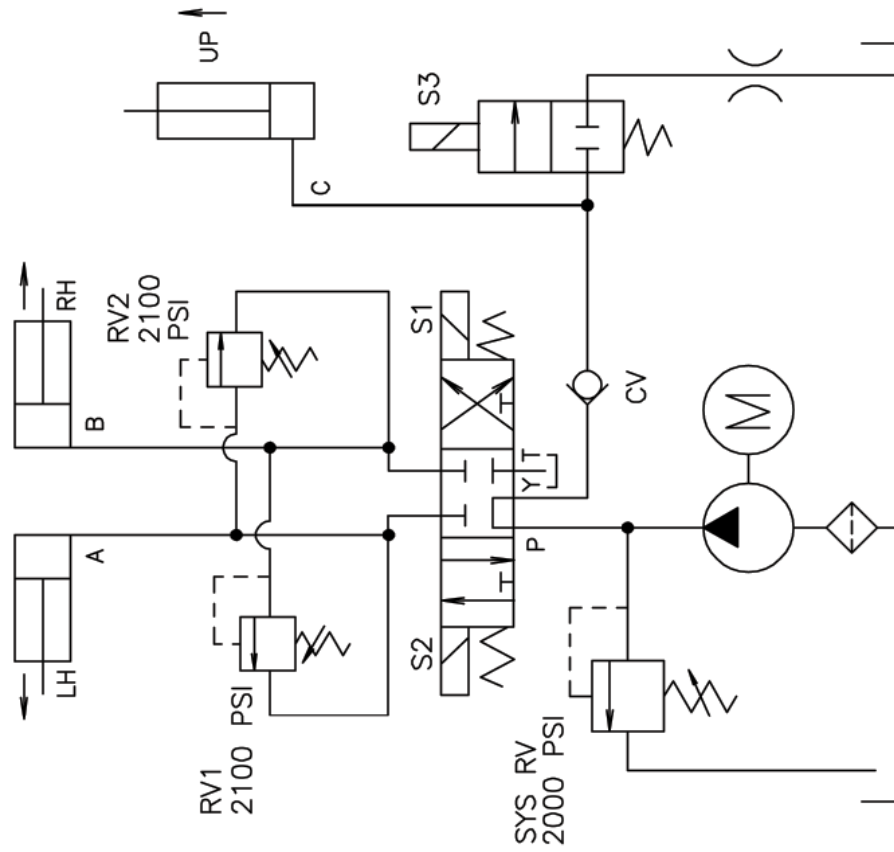

- S1 - RIGHT EXTEND - GRAY WIRE
- S2 - LEFT EXTEND - TAN WIRE
- S3 - DOWN - BLUE WIRE

STRAIGHT FLOW POWER UNIT - KTI

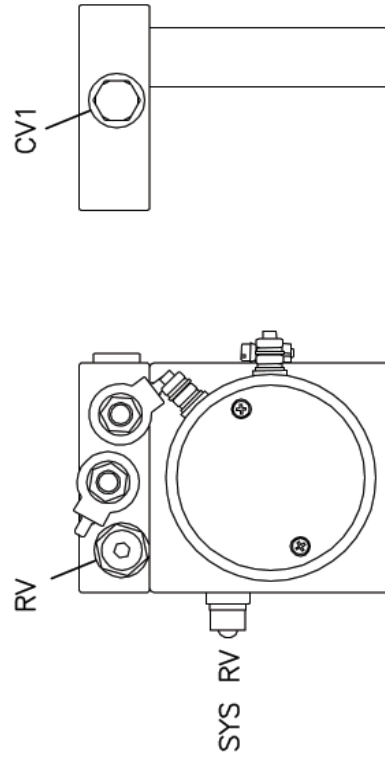
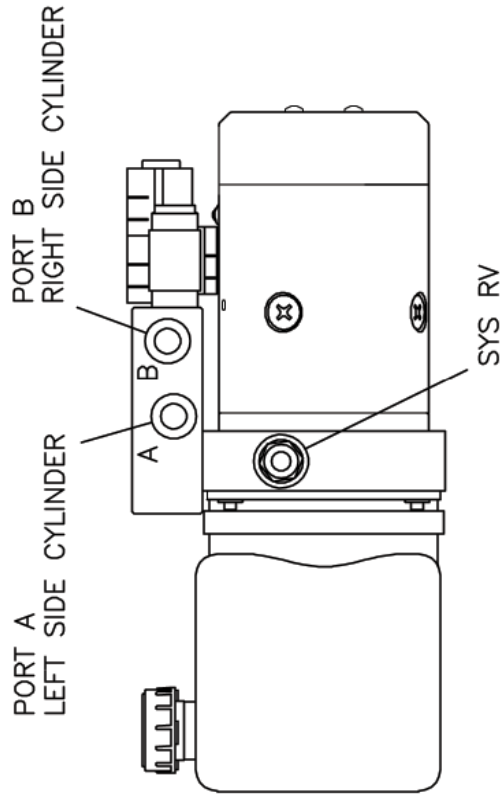
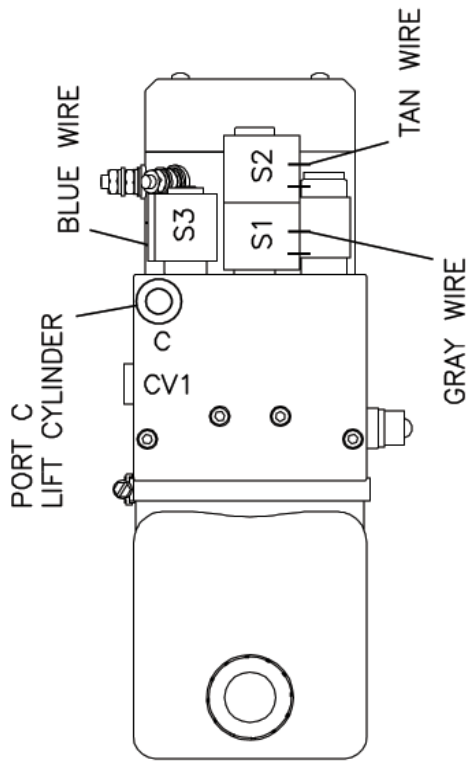

RV - CROSSOVER RELIEF VALVE, 2100 PSI
SYSRV - RELIEF VALVE, SYSTEM, 2000 PSI

POWER UNIT HYDRAULIC CIRCUIT DIAGRAM-KTI

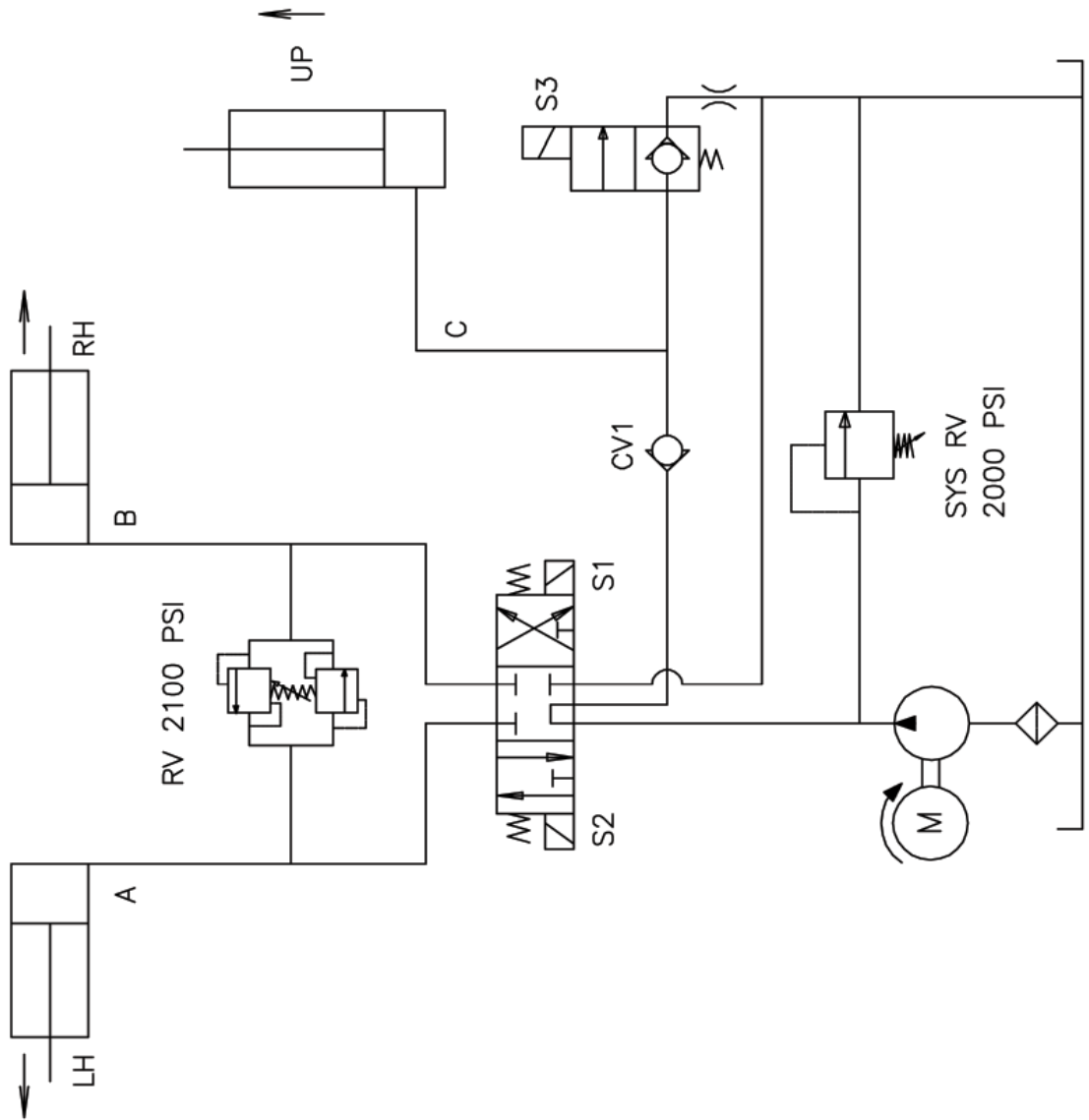

S1 - RIGHT EXTEND - GRAY WIRE
 S2 - LEFT EXTEND - TAN WIRE
 S3 - DOWN - BLUE WIRE

SPECIFICATIONS

	Model 702 7' Poly Plow	Model 752 7 1/2' Poly Plow	Model 702SS 7' Stainless Plow	Model 752SS 7 1/2' Stainless Plow
Blade Width	7'	7 1/2'	7'	7 1/2'
Plow Width at 25°	6'4"	6' 9 1/2"	6' 4"	6' 9 1/2"
Blade Height	26"			
Cutting Edge	3/8" x 6" 1084 steel w/standard highway punch			
Weight	467 lbs.	474 lbs.	494 lbs.	508 lbs.
Recommended Hydraulic Fluid	Hiniker Cold Flow Mil Spec 5606 or Equivalent			
Hydraulic Fluid Capacity	2 Quarts			
High Beam Bulb	One #H1, 12V 55W			
Low Beam Bulb	One #H7, 12V 55W			
Turn Signal/ Parking Bulb	One # 1157 heavy duty double contact 32/3 C.P. 12 VDC			
Motor Solenoid	12 VDC solenoid continuous duty, sealed			
Wiring Harness Fuse	10 AMP			
Hose Ends	9/16-18 JIC Female Swivel			

HINIKER WARRANTY

HINIKER SNOWPLOW LIMITED WARRANTY

The only warranty Hiniker Company (Hiniker) gives and the only warranty that any Hiniker dealer is authorized to give on behalf of Hiniker is as follows: **(NO EMPLOYEE OR REPRESENTATIVE IS AUTHORIZED TO CHANGE THIS WARRANTY IN ANY WAY OR GRANT ANY OTHER WARRANTY.)**

Hiniker warrants to the original purchaser of a Hiniker snowplow that Hiniker will repair or replace any defects in material and workmanship that occur within two years from date of retail delivery except the following items: Hiniker warrants that it will repair or replace any defects in materials or workmanship with respect to the paint finish, any accessories, and service parts and components for a period of one year from date of retail delivery.

Hiniker's obligation and liability under this warranty is expressly limited to repairing or replacing, at Hiniker's option, at an authorized Hiniker dealer location, the defective parts at no charge to the original purchaser. **HINIKER MAKES NO OTHER WARRANTY, EXPRESS OR IMPLIED AND MAKES NO WARRANTY OF MERCHANTABILITY OR OF FITNESS FOR ANY PARTICULAR PURPOSE.**

HINIKER'S OBLIGATION UNDER THIS WARRANTY SHALL NOT INCLUDE ANY TRANSPORTATION CHARGES TO OR FROM THE AUTHORIZED HINIKER DEALER LOCATION OR ANY LIABILITY FOR INCIDENTAL, INDIRECT OR CONSEQUENTIAL DAMAGE OR DAMAGES OF ANY KIND FOR LOST PROFITS OR DELAY. If requested by Hiniker, products or parts for which a warranty claim is made are to be returned freight prepaid to our factory. Any improper use, operation beyond rated capacity, substitution of parts not approved by Hiniker Company, or any alteration or repair in such manner as in our judgment affects the product materially and adversely shall void this warranty.

Hiniker reserves the right to make improvements or changes to any of its products without notice. Such improvements or changes shall not trigger any obligation by Hiniker to update, modify or change any products previously sold by Hiniker.

HINIKER does not warrant the following:

1. Used products.
2. Any product that has been repaired, modified or altered in a way not approved by Hiniker Company.
3. Depreciation or damage caused by normal wear, lack of reasonable and proper maintenance, failure to follow Operators Manual Instructions, misuse, lack of proper protection during storage, or accident.
4. Parts replacement and service necessitated by normal wear or maintenance including, but not limited to, cutting edges, hoses, snowplow skid shoes, blade marker guides and hardware.
5. Paint finish damage caused by normal wear.

Hiniker does not assume any liability for any damage to a motor vehicle resulting from the attachment or use of a Hiniker snowplow. Compliance with applicable motor vehicle regulations is the responsibility of the installer. Attachment of a Hiniker snowplow to a motor vehicle is at the risk of the purchaser.

It is the responsibility of the original snowplow purchaser to verify the original date of purchase.

A DELIVERY REPORT FORM must be filled out and received by Hiniker with 30 days of retail delivery at the address below to initiate the warranty coverage.

HINIKER COMPANY
58766 240th St.
MANKATO, MN 56001
PHONE (507) 625-6621 -- FAX (507) 625-5883
www.hiniker.com