



**PICKUP TRUCK SNOWPLOW
SCOOP PLOW
Models 6800, 6900**

OPERATOR'S MANUAL

DO NOT USE OR OPERATE THIS EQUIPMENT UNTIL THIS MANUAL
HAS BEEN READ AND THOROUGHLY UNDERSTOOD

PART NUMBER 25011692 Rev. E

TABLE OF CONTENTS

25011692 Rev. E

2/10

Hiniker/25011692RevE

TO THE PURCHASER	2
SAFETY	3
OPERATING PROCEDURES	4
TROUBLE SHOOTING	9
MAINTENANCE	11
ASSEMBLY	13
SYSTEM CHECK-OUT AND JOYSTICK CONFIGURATION	23
HEADLAMP AIMING PROCEDURE	25
ELECTRICAL CIRCUIT	26
HYDRAULIC CIRCUIT	29
SPECIFICATIONS	30
WARRANTY	31

TO THE PURCHASER

This product is designed and manufactured to give years of dependable service, when properly maintained and used for the purpose for which it is intended. Never allow anyone to operate this equipment until they fully understand the complete contents of this manual. It is the responsibility of owners who do not operate this equipment to ensure the operator is properly instructed and understands the contents of this manual. It is also the owner's responsibility to ensure that anyone operating this equipment is mentally and physically capable of so doing.

Important information is contained in this manual to help ensure safe and efficient operation.

If you have any questions about this manual, or the equipment discussed herein, contact your Hiniker dealer.



This is a safety alert symbol. It alerts an operator to information concerning personal safety. Always observe and heed these instructions, otherwise death or serious injury can result.

All references to LEFT or RIGHT are defined as viewing the plow from the cab of the truck.

This Operator's manual is shipped with this equipment. Contact your Hiniker dealer for additional copies.

Always obtain original Hiniker service parts. Substitute parts could adversely affect equipment performance and warranty.

Check that your dealer has forwarded to Hiniker company the delivery report form along with the plow identification number because it helps to maintain maximum service and warranty benefits. This does not put you on any mailing list, and information thereon is not available to others.

Your plow's identification number decal is at location (1) in the following illustration.

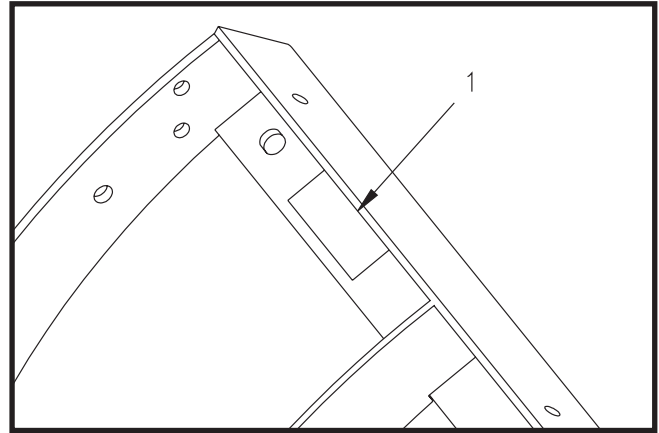

DWG NO. 5401

Record the following information for later reference when obtaining service parts:

Purchase Date

Purchaser's Name

Dealer's Name

Machine Serial No.

SAFETY



This is a safety alert symbol. It alerts an operator to information concerning personal safety. Always observe and heed these symbols and instructions, otherwise death or serious injury can result.

Operator safety is a principle concern in equipment design and distribution. However, many accidents occur because a few seconds of thought, and a more careful approach to handling, were ignored.

Accidents can be avoided by knowing and following the precautions cited in this manual.

GENERAL SAFETY

1. Read this manual thoroughly. Make sure the operator understands it and knows how to operate this equipment safely. This equipment can kill or injure an untrained or careless operator and bystanders. If you sell this equipment, ensure the new owner acknowledges receipt of this manual.
2. This plow is intended for plowing snow only. Plowing gravel, rocks, etc., or using the plow for any purpose other than plowing snow could result in harm to the operator or bystanders or cause damage to the plow or vehicle.
3. Do not service or otherwise handle a plow in the raised position unless it is securely blocked against unexpected falling.
4. Do not attempt to handle or service this equipment, and direct others to do the same, unless you know how to do it safely and have the proper tools for the job.
5. Keep hands, feet, hair, and clothing away from moving parts.
6. Do not alter the equipment.

BEFORE OPERATION

1. Discipline yourself to visually check for worn, damaged or cracked parts before starting use. Replace these with genuine Hiniker parts.
2. Escaping hydraulic oil under pressure can penetrate the skin, causing serious injury.

Do not use your hand to check for leaks. Use a piece of paper or cardboard to find suspected leaks.

Tighten all connections before pressurizing hydraulic lines.

If fluid is injected into the skin, get medical attention immediately to prevent serious infection.

3. Check all controls and operating functions of the machine in a safe area before starting to work.

DURING OPERATION

1. Always wear seat belts when operating a motor vehicle.
2. Ensure everyone is clear of the machine, especially away from blind areas of the operator, before starting, actuating hydraulics or operating this equipment.
3. Do not plow snow at excessively high speeds.
4. Avoid hitting objects that will damage your plow or truck.
5. Set the brakes and stop the truck's engine before adjusting or servicing your plow.

AFTER OPERATION

1. Park the plow on a solid, level surface. Fully collapse the lift cylinder with the upper lift links before unhitching the plow to prevent the plow frame from falling forward.

OPERATING PROCEDURES

ATTACHING THE PLOW

Attachment prongs on the truck should be mounted such that the bottom edge of the prongs measure about 10 inches above the ground. Prong receivers on the plow frame should remain parallel to the ground and at the correct height by fully retracting the lift cylinder with the upper lift links before removing the plow from the truck (See "Removing the Plow") Ideally, the prongs on the truck should lift the plow frame slightly when driving into the plow for attachment.

Powdered graphite applied on the prongs will help the plow slide on and off more easily.

Check that prongs are in line with the receivers before driving into the plow. Lightly tap the gas pedal until the truck prongs slide into the back of the receivers, then gradually bring the truck to a stop. Slamming on the brakes will cause the plow to slide forward and the notches on the prongs and receivers will not line up. Set the parking brake in the truck to prevent it from creeping back out from the receivers.

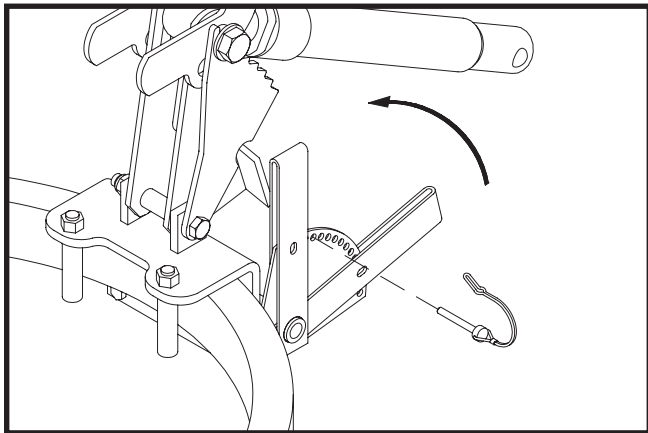

DWG NO. 5617A

Remove the tab lock pin from the parking stand index plate to raise the stand to its highest position. Reinstall the pin in the plate for transport.

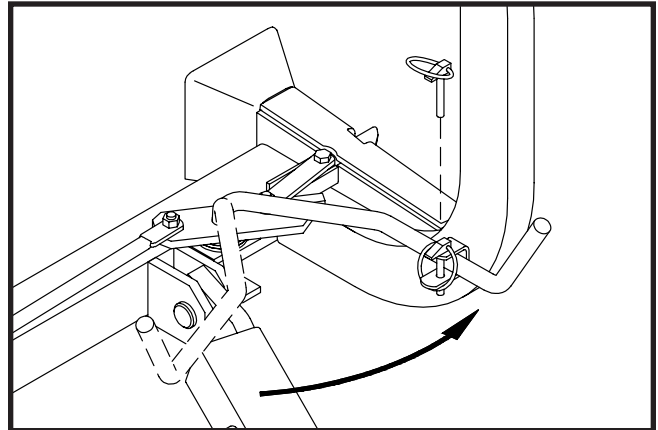

Handle Pinned With Plow On Truck DWG NO. 4199

Pull the latch handle into the clevis on the lift frame to force the sliders through the notches in the prongs and receivers. Check that both sliders are fully engaged. Pin the handle in the clevis with its klik pin. Failure to pin the handle in place may allow the plow to fall off the truck.

NOTE: Before connecting the plow's wiring to the truck, make sure power is switched "Off" on the joystick controller.

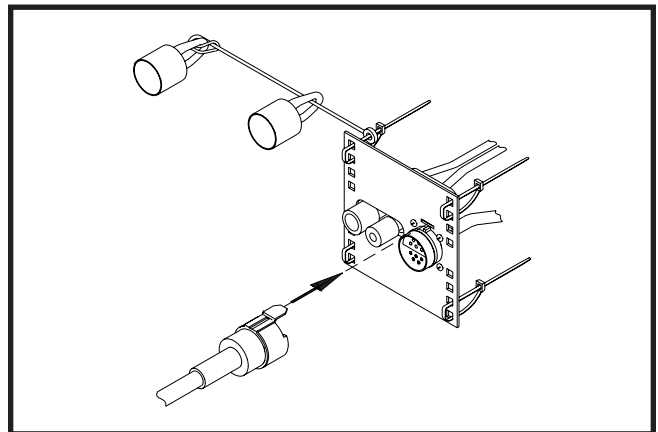

Alignment Tab and Slot

DWG NO. 3922

Plug in the two electrical connectors between the plow and the truck after latching the plow. The alignment tab on the 10-pin receptacle will mate with the slot in the mounting plate on the truck grill to ensure proper connection.

Check that the plow headlamps and turn signals are operational, and headlamps are aimed correctly. Test the lift and angling cylinders in a safe area before using the plow.

To make alignment of the plow easier in the future, mark a point on the back of the head lamp, a point on the hood near the front of the truck and a point on the windshield that are in line when you are seated behind the steering wheel. Line up these three points when driving into the plow.

THE JOYSTICK CONTROLLER

The joystick control box has slide switches for controlling power to the snowplow and for switching from the truck headlights to the headlights on the plow.

The joystick controller raises and lowers the plow and angles the blade left or right.

The default setting for the 4-way switch is shown on drawing 4176. The Joystick may be configured to reverse the Raise/Lower functions. See the section JOYSTICK CONFIGURATION for performing this operation.

The vehicle's electrical power must be turned on before the control box will function.

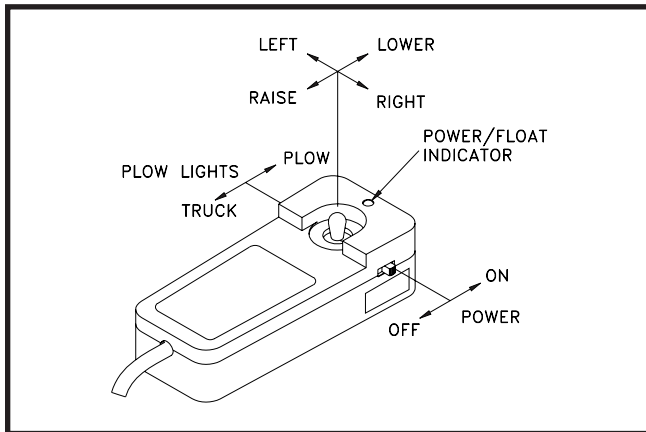

Joystick Control Box

DWG NO. 4176

Place the on/off switch on the joystick control box in the "On" position to supply power to the snowplow. A green light will indicate power is on.

Move the headlight slide switch on the control box to the "Plow" position to change from the truck lights to the snowplow lights. Activate high beam/low beam and turn signal/parking lamps from the

truck as you normally would without the plow attached.

NOTE: When removing the plow, remember to place the headlight switch in the "Truck" position to return power to the truck's headlights.

Raise or lower the plow by moving the joystick to the "Raise" or "Lower" position. Hold the plow at an intermediate height by releasing the controller from the "Raise" position when the plow reaches the desired height.

Moving the controller to the "Lower" position will lower the blade to the ground and allow the plow to "Float" along the contour of the ground while plowing snow.

A yellow light on the control box indicates the plow is in the float mode. Momentarily moving the joystick to the "Raise" position will remove the plow from the float condition and the yellow indicator will return to green.

Move the joystick left or right to angle the blade. Release the joystick when the blade is at the desired angle.

TRANSPORTING THE PLOW

The extra weight of the snowplow on your truck will impair handling response and increase braking distance.

The plow will also block some airflow to the vehicle's cooling system, possibly causing the vehicle to overheat. Therefore, it is important not to exceed speeds above 45 mph when the plow is attached. Remove the plow if you must drive your truck for long distances when the temperature is warm.

Raise the blade to a position where it will not interfere with the headlights before driving. Transport the plow with power to the joystick control box switched off to prevent accidental lowering of the plow.

Never adjust the blade height or angle the blade while driving.

PLOWING SNOW



WARNING: Always wear a seat belt when plowing snow. Sudden contact with a hidden object can result in serious personal injury.

Inspect areas to be plowed before snowfall for potential hazards, and mark obstructions with stakes that will be seen when snow covers the ground. Identify any emergency equipment and utility outlets that may need to be cleared in the event of a storm. Prepare a plan beforehand for clearing snow from tight or enclosed areas and locate sites for stacking snow.

Adjust the skids at the back of the moldboard according to the surface to be plowed. The bottom of the skids should be about 1/2" below the cutting edge when plowing gravel roads or lots. Skids should be even with the cutting edge on hard surfaces such as asphalt or concrete.

Always plow snow as it is accumulating. Wet snow may weigh about 12 pounds per cubic foot. The weight of snow being pushed by your plow may increase to several tons.

Allowing snow depth to grow to unmanageable levels can cause difficult removal problems and can be costly in terms of wear on equipment.



WARNING: Serious personal injury can result from plowing at excessive speeds, as well as costly damage to equipment and property, if an obstruction is encountered while plowing. Do not exceed 10 mph while plowing.

Plow snow in the lowest truck gear to transfer maximum power to the cutting edge. Clear areas in front of buildings first. Back drag snow away from buildings by driving to the building with the plow raised, then dropping the blade to pull snow away from buildings.

Clear large lots by angling the blade and creating a single path. Roll snow to outer edges of the lot by taking successive passes with the blade angled.

When plowing very deep snow, it may be necessary to raise the blade and shear off layers of snow until a working area is cleared. Work small areas

in multiple passes to push snow to outer edges. Generally, 6 inch snow can be plowed with the entire blade width; 9 inch snow with 3/4 of the blade width; 12 inch snow with 1/2 of the blade width. Local conditions will determine how much work can be done before stalling or getting stuck.

PARKING

Lower the plow to the ground when parking your truck for a long period of time with the plow attached. Place the on/off switch in the "Off" position to prevent the plow from drawing power from the truck battery. The plow's power unit may continue to draw electrical current from the truck battery if the control switch is left on; possibly resulting in insufficient charge to start the truck.

REMOVING THE PLOW

To remove the snowplow from your truck, park on a solid level surface with the blade straight. Lower the plow to the ground and leave the controller in the "Float" mode.

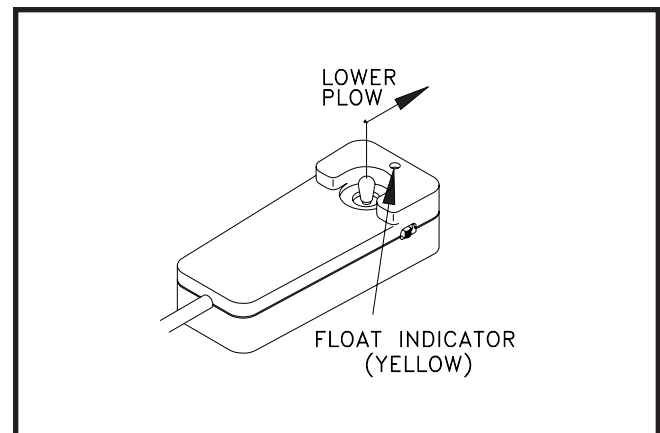

Lower Plow, Leave Controller in "Float" DWG NO. 4177

NOTE: The plow control box must be in the "Float" mode to move the cylinder rod. If the cylinder rod does not retract with power on and the controller in float, loosen the packing nut on the lift cylinder up to 1-1/2 turns to reduce friction.

With the plow lowered to the ground and the controller in the "float" mode, push down on the upper lift links to fully retract the lift cylinder rod.

Retracting the lift cylinder will orient the prong receivers correctly for reattaching the plow later. Failure to retract the lift cylinder rod will allow the lift frame to fall forward, possibly causing personal injury or damage to plow components.

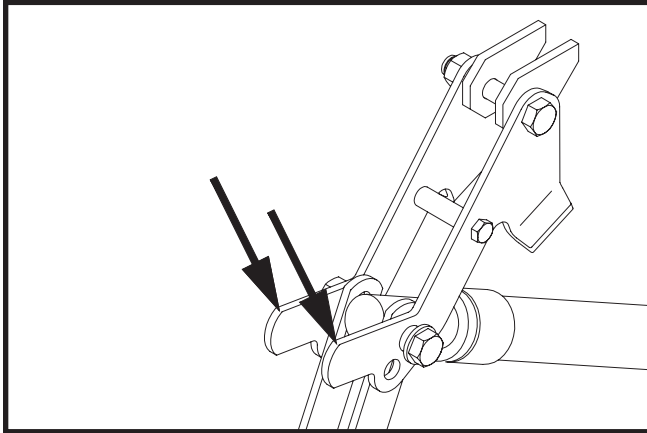

Retract Cylinder With Upper Lift Links DWG NO. 6000

Rotate the stop plate up to contact the spacer bushing on the lift cylinder bolt.

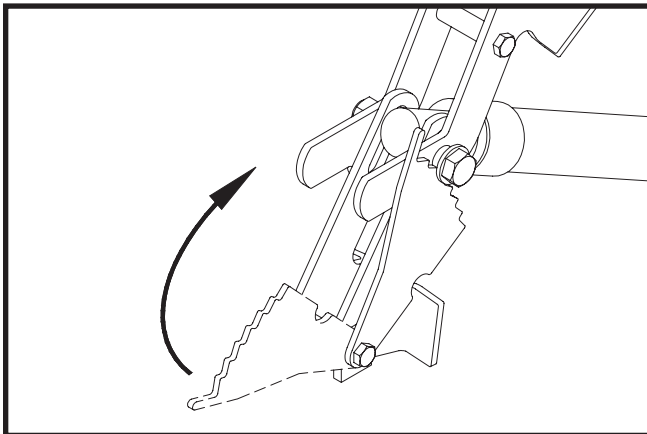

Rotate Stop Plate DWG NO. 6004

Gently push back on the headlight bracket to tilt the lift frame back as far as possible, then release the bracket to allow the weight of the lift frame to lock the stop plate in place.

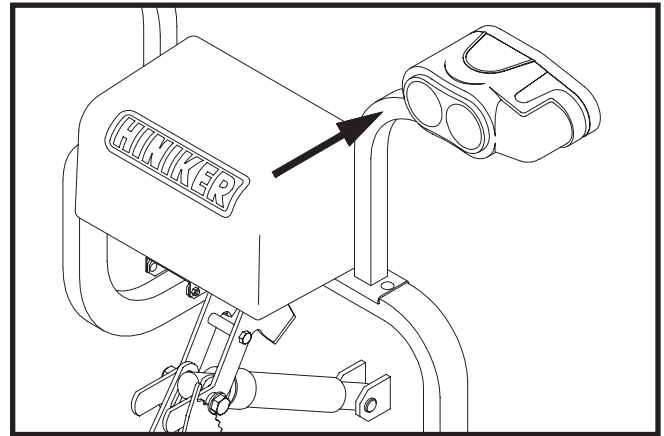

Push Lift Frame Back

DWG NO. 6005

Swing the latch handle open until the latch sliders are fully removed from the attachment prongs.

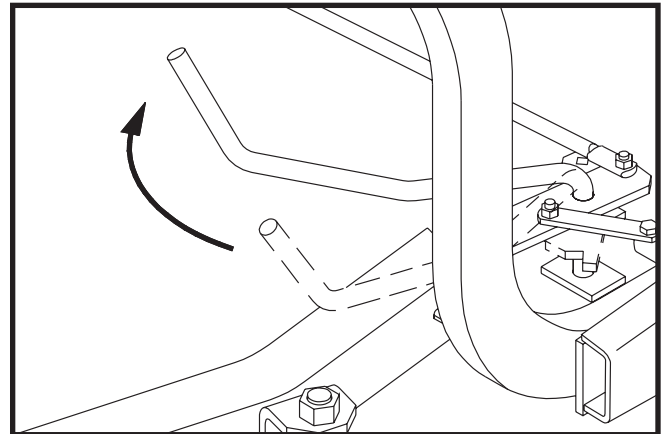

Swing Handle To Remove Sliders

DWG NO. 3856

Lower the parking stand to the ground by removing the tab lock pin from stand index plate, then swinging the stand to the ground with the lever.

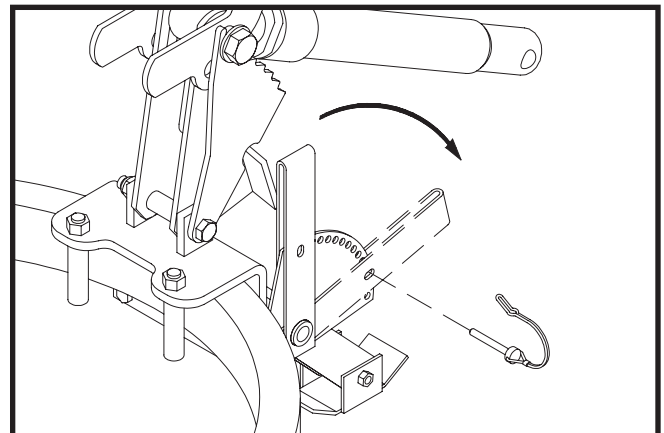

Lower and Pin Parking Stand

DWG NO. 5251A

Reinstall the pin in the index plate through the hole in the lever to hold the stand in place.

8 Operating Procedures

Disconnect the electrical connectors by pulling them straight out from the receptacles. Do not twist the connectors, twisting will damage the connector pins or the wiring harness.

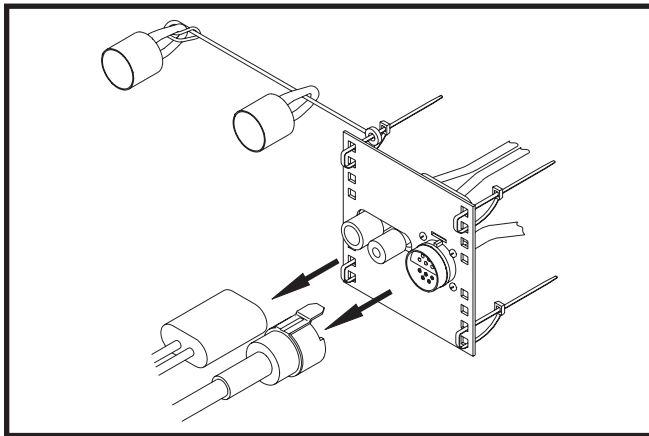

Disconnect Plugs

DWG NO. 3925

Back inside the truck, return control of the headlights to the truck and switch power off on the snowplow control box, then slowly back the truck out from the plow.

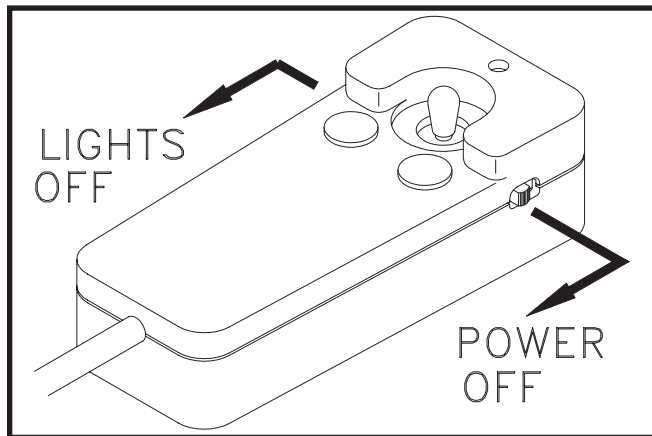

Turn Off Lights and Power

DWG NO. 4164

NOTE: The stop plate will automatically fall toward as soon as the lift cylinder is fully extended for raising the blade prior to transporting the plow.

If the snowplow won't be used for an extended period of time, the prong weldment can be removed from the truck by removing the hex bolts that fasten it to the truck mount frame.

TROUBLE SHOOTING

GENERAL

1. Check to see that the motor is wired correctly with tight connections, for the proper voltage.
2. Check reservoir oil level.
3. Check that wiring harness relay connections are wired correctly
4. Check for external leakage at cylinders, hoses and power unit.

PROBLEM	POSSIBLE CAUSE	REMEDY
1. Plow does not attach to vehicle	A. Receivers are tipped forward	A. Fully collapse lift cylinder and rotate stop plate up to brace the lift frame before removing plow from truck.
	B. Prongs recoil out of receivers when attaching	B. Slowly drive into receivers and set parking brake
	C. Park stand pinned too low	C. Lower receivers by adjusting park stand
2. Pump motor does not run	A. Defective solenoid	A. Replace solenoid
	B. Defective pump motor	B. Replace brushes or pump motor
	C. Weak or defective battery	C. Charge or replace battery
	D. Bad electrical connections	D. Clean and tighten connections
	E. Defective joystick control box	E. Replace control box
	F. Blown fuse supplying power to control box	F. Replace fuse
3. Pump runs with joystick in neutral position	A. Defective solenoid	A. Replace solenoid
	B. Defective joystick control box	B. Replace control box
	C. Wiring short	C. Locate and repair
4. Plow will not lower	A. Reversed wiring on valve block	A. Correct wiring
	B. Defective joystick control box	B. Replace control box
	C. Defective lift return valve or coil	C. Replace valve or coil
5. Hydraulic cylinder does not function or functions slowly, motor runs	A. Weak or defective truck battery	A. Charge or replace battery
	B. Oil level low	B. Add oil (do not overfill)
	C. Hydraulic connection leak	C. Tighten or redo connection
	D. Solenoid valve not opening properly	D. Replace valve
6. Plow does not remain raised with joystick in "neutral" position	A. Leakage through pump check valve	A. Clean valve, or replace
	B. Leakage through solenoid lowering valve	B. Clean valve, or replace
	C. Internal leakage in cylinder	C. Repack or replace cylinder
	D. Defective joystick control box	D. Replace control Box

10 *Trouble Shooting*

PROBLEM	POSSIBLE CAUSE	REMEDY
7. Angling cylinders relieve too easily or too difficultly while plowing	A. Relief pressure set too low or too high	A. Have relief pressure adjusted by Hiniker snowplow dealer
8. Oil leaks from cylinder(s)	A. Loose packing B. Defective cylinder	A. Tighten packing 1/8 turn B. Repack or replace cylinder
9. Battery goes dead with power to the control box on and joystick in neutral position.	A. Short in wiring B. Defective joystick control box	A. Locate and repair B. Replace control box
10. Battery goes dead with power to the control box off.	A. Short in wiring	A. Locate and repair
11. Plow parking/turn lights are dim	A. Bad connection(s) B. Lights not properly grounded	A. Repair connection B. Properly ground
12. Plow does not clean-up snow from low areas	A. Controller not in float mode	A. Controller should be in the float mode
13. In extremely cold temperatures, the oil in the hydraulic system is thickened, causing slow functioning of the plow	A. Cold temperatures	A. As the system warms, the oil will thin out and function normally B. Select Hiniker Cold Flow Hydraulic Oil for plowing in extremely cold temperatures
14. Pump chatters when raising plow	A. Hydraulic oil low	A. Add hydraulic oil until chattering stops. Do not overfill
15. Oil running out of cap on hydraulic reservoir	A. Plowing on steeply inclined terrain B. Too much oil	A. Avoid excessive inclines or change direction of plowing B. Remove excess oil
16. Vehicle overheats with the plow on	A. Vehicle coolant level low B. Ice and snow buildup in grill C. Insufficient airflow to engine compartment	A. Add coolant B. Remove ice and snow C. Transport plow at lower speeds
17. Plow lights do not operate with plow attached	A. Light switch on joystick control box in "truck" position B. Defective relay C. Faulty light switch on joystick control box D. Blown fuse on vehicle accessory feed	A. Move switch to "plow" position B. Replace relay C. Replace joystick control box D. Replace fuse
18. Truck headlights do not operate properly with plow removed	A. Light switch on joystick control box in "plow" position B. Defective relay	A. Move switch to "truck" position B. Replace relay
19. Poly moldboard is bowing or cracking	A. Moldboard bolts are too tight.	A. Loosen the bolts so the plastic can expand and contract

MAINTENANCE



WARNING: Do not service or otherwise handle a plow in the raised position unless it is securely blocked against unexpected falling.

Dependable snowplow operation is the result of following good maintenance procedures. Inspect your plow frequently to ensure that all parts are working smoothly, and develop a schedule for maintenance at required intervals.

GENERAL

Wash salt and dirt off the plow before storage. Touch-up any chips or scratches in the paint and apply a light coating of grease to extended cylinder rods to prevent corrosion.

HYDRAULIC SYSTEM

The majority of snowplow operational problems are caused by bad oil in the hydraulic system. Hydraulic oil should be changed every year for best performance.

Select Hiniker Cold Flow Hydraulic Oil or an equivalent oil that meets military specification 5606, for plowing in extremely cold temperatures.

To change hydraulic oil, disconnect the electrical wiring harnesses from the snowplow power unit and uncouple three hydraulic lines. Unbolt the power unit from the plow, and remove it to a clean working area that can capture any spilled oil.

Carefully unbolt the oil reservoir from the power unit and discard old oil. Purge old oil from the angling cylinders by forcing rods to retract.

Clean the suction filter at the pump inlet and wipe any metal shavings off the magnet on the pump.

Re-attach the reservoir onto the power unit and re-connect the power unit on the snowplow before adding new hydraulic oil.

Re-attach hydraulic hoses and electrical wires at the correct locations on the power unit.

Pour hydraulic oil into the power unit reservoir until the reservoir is half full. Angle the plow full left or right to fill the angling cylinder with oil, then add more oil until the oil reaches the fill line - about 1 1/4 inches from the top. Do not overfill the reservoir.

Cycle the plow left and right and up and down, to purge any air trapped in the system.

Check the oil level with the plow on the ground. Add oil to the fill line, if necessary, but do not overfill the reservoir.

ELECTRICAL MAINTENANCE

Periodically check all electrical connections for proper fit and remove any contamination that may be present.

To prevent contamination always place dust caps on connectors when not in use. This is particularly important when the plow is being stored. The use of dielectric grease is recommended to reduce corrosion of the contacts and to make connecting and disconnecting easier.

Before each season check vehicle battery and electrical system for proper operation. A weak battery, dirty terminals, or faulty charging system may cause improper operation and possible failure of the joystick controller.

Before every plowing season, and throughout the season, check the snowplow headlamps for proper function and aim. Refer to sections titled "System Check-Out" and "Headlamp Aiming Procedure" in this manual for instructions.

MECHANICAL COMPONENTS

Prior to the operation of a new snowplow, or one which has been stored, inspect all hardware and verify proper torque value on all bolts and nuts in accordance with the recommended torque specifications.

GRADE 5 TYPE B & F LOCK NUT TORQUE VALUES

Diameter	Ft-lbs.	N-m
5/16"	13-18	17-25
3/8"	23-33	31-44
1/2"	58-82	79-112
5/8"	117-165	158-223

GRADE 5 BOLT TORQUE VALUES*

Size	Ft-lbs.	N-m
1/4"	8-12	11-16
3/8"	29-41	39-56
1/2"	73-103	99-140
5/8"	146-206	198-279

Loose bolts can cause hole elongation and part failure resulting in dangerous operating conditions and equipment breakdown.

Check all hardware periodically during operation and keep tightened to specified torque value. Replace worn bolts and lock nuts with grade 5 bolts and equivalent type B or type F lock nuts. Type B lock nuts are plain hex; type F lock nuts are flanged hex.

Inspect wear of cutting edges before every plowing season and frequently throughout the season. Replace the cutting edge before wear reaches the main plow blade.

The 5/16" hex bolts in the latch sliders are factory retained with anaerobic threadlock. If removal or replacement of these bolts is necessary, purchase new bolts with threadlocker from your Hiniker dealer, or apply a commercially available threadlock, i.e., Loctite 242 (blue) or Perma-Lok HM118 (red), to standard 5/16-18 X 3/4" grade 5 hex bolts before reassembly.

PLOW ASSEMBLY

GENERAL INFORMATION



WARNING: To prevent personal injury or death, be certain to keep clear of any parts that may drop when removing bundling straps, wires or brackets. Support heavy sections with hoist or blocks before removing wires or straps.

In the following instructions, left and right machine references are defined as being viewed from the cab of the truck.

Be certain that hydraulic hoses and electrical wires are safely routed and allow full motion of moving parts. Secure loose wires with plastic tie straps.

Some components are fastened at incorrect locations for shipping purposes.

All hardware should be tightened only enough to insure safety during assembly. Torque hardware to specified values, as shown in the following chart, only after assembly has been completed.

GRADE 5 TYPE B & F LOCK NUT TORQUE VALUES

Diameter	Ft-lbs.	N-m
5/16"	13-18	17-25
3/8"	23-33	31-44
1/2"	58-82	79-112
5/8"	117-165	158-223

GRADE 5 BOLT TORQUE VALUES*

Size	Ft-lbs.	N-m
1/4"	8-12	11-16
3/8"	29-41	39-56
1/2"	73-103	99-140
5/8"	146-206	198-279

* applications without lock nuts

Replace worn bolts and lock nuts with grade 5 bolts and equivalent type B and type F locknuts. Type B lock nuts are plain hex; type F lock nuts are flanged hex.

PLOW ASSEMBLY

1. Place moldboard face down on cardboard or other padding that will prevent scratches in the paint.

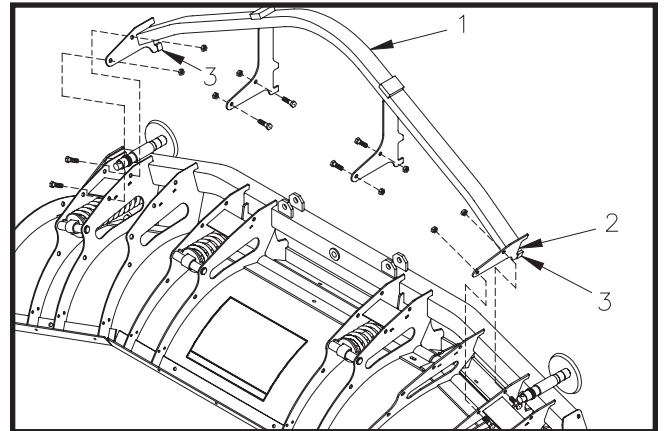

DWG NO. 5402

Wrap hoist straps or padded chains firmly around the quadrant weldment (Arrow 1). Remove the eight 1/2" X 1-1/4" bolts and 1/2" lock nuts from the quadrant weldment and moldboard assembly. Remove the two caps (Arrow 3) from the ends of the quadrant ribs (if equipped).

Attach the quadrant weld (Arrow 1) into its working position by lining up the slot on one end (Arrow 2) of the quadrant weld with the 3 X 3 tube. Then, insert a 1/2" bolt into that end of the quadrant weld to hold it in place.

Next, pry the other end of the quadrant weld with a 2 X 4 until the slots on the quadrant weld line up with the 3 X 3 tube, Then pound it into place with a rubber hammer.

Use a drift punch to line up the holes on the side that was pounded in, then insert another 1/2" bolt. Finally, insert the other 1/2" bolts and secure with 1/2" lock nuts.

14 Plow Assembly

2. Open the frame crate and set aside the power unit box, headlamp boxes and parts box for later. Carefully lift the frame assembly from the crate by wrapping hoist straps or padded chains around both ends of the 2 1/2 inch square tube at the back of the frame assembly.

Remove the 3/4 inch hex bolt, arrow 1 in drawing 5420A, and two 1/2 inch hex bolts, and spacers, arrow 2, from the push frame.

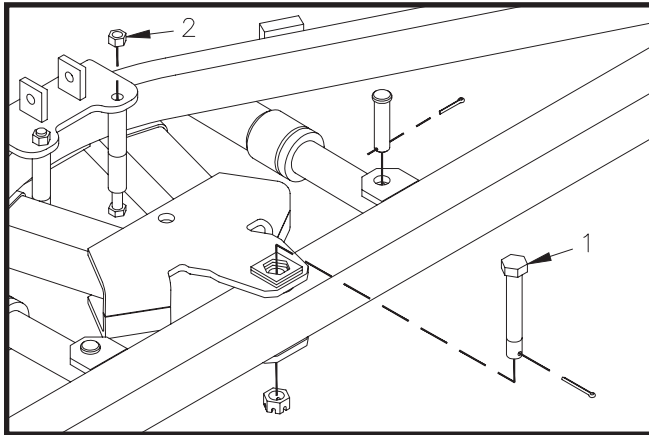

DWG. NO. 5420A

Align the push frame hitch plates with the pivot hole in the moldboard tube, then reassemble the 3/4 inch hex bolt slotted nut and cotter pin. Install the nut so that the assembly is secure, but frames will pivot.

Reassemble the two 1/2 inch hex bolts, spacers and lock nuts at their original locations and fully tighten hardware.

Remove clevis pins from the rod ends of the two angling cylinders. Loosen the plugs in the cylinder ports and extend the cylinder rods to the lugs on the back of the moldboard. Pin the rods between the lugs with the clevis pins and cotter pins.

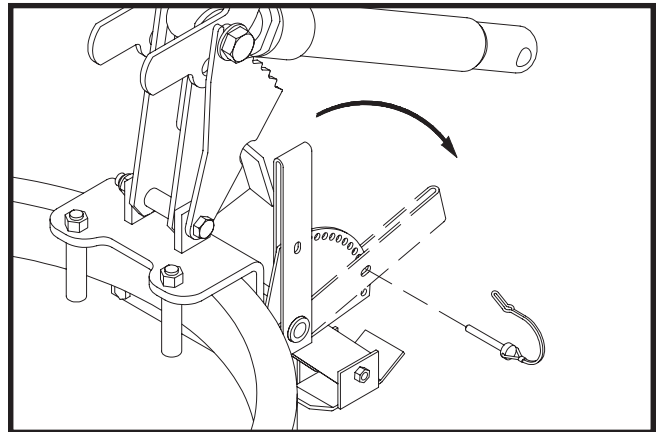

Lower and Pin Parking Stand

DWG NO. 5251A

3. Tip the moldboard and frame assembly to their working position with a hoist or fork truck. Pin the parking stand to hold the square tubes of the push frame parallel to the ground. Adjust the skid assemblies as needed to accommodate this working position.

Swing the lift frame to its approximate working position and hold it with a hoist or forklift for assembly of the lift mechanism.

The bottom surface inside the two prong receiver channels should measure approximately 10 inches above the ground in the working position.

4. Locate a 90° O-ring/flare adapter in the hardware bag and the lift cylinder from the parts box. Turn the O-ring end into the port of the lift cylinder so that the flare end is toward the rod end of the cylinder when tightened.

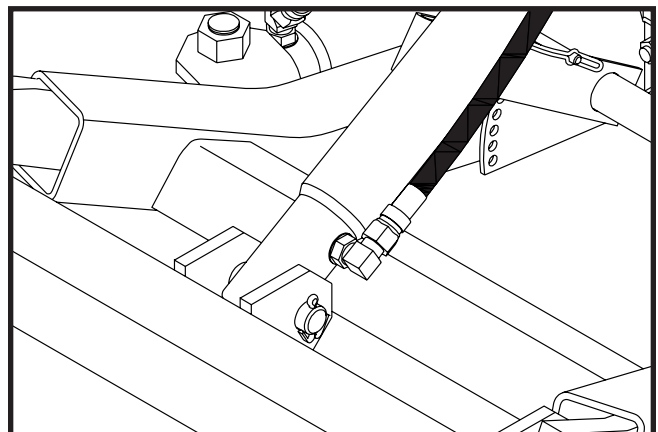

DWG NO. 4202

Pin the base of the cylinder between the center lugs of the lift frame with the 3/4" x 3" clevis pin. The hydraulic fitting should be on the right side of the cylinder.

Remove four lift links and the stop plate kit from the parts box. From the hardware bag remove two 3/4 inch hex bolts, two 3/4 inch I.D. shim washers and one 3/4 inch nylon insert lock nut. Also remove the 1/2 inch hex bolt and upper link spacer bushing.

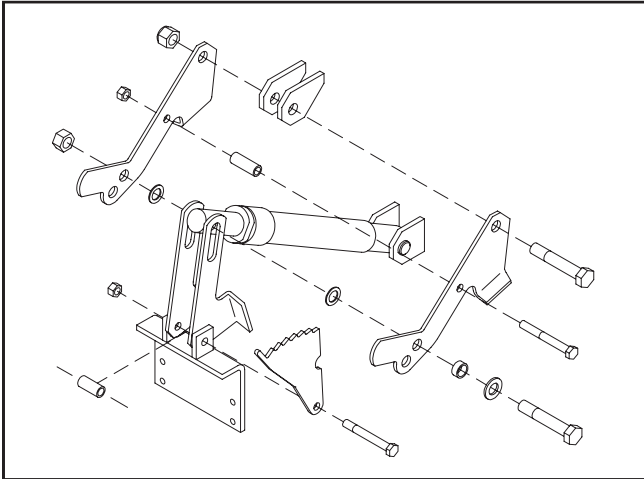

DWG NO. 6585

Identify the RH and LH upper and lower links by referring to drawing 6585. Assemble the links with their stop surfaces away from the lift cylinder.

Remove the 1/2 inch hex bolt and spacer from between the tabs on the push frame. Slide the stop plate onto the bolt, as shown in the drawing, then bolt the two lower links inside the tabs, with the spacer between the links.

Assemble the two upper lift links outside the lugs on the lift frame with a 3/4 inch x 4 1/4 inch hex bolt and nylon insert lock nut.

Bolt the upper link spacer bushing between the two upper links with the 1/2 inch hex bolt and lock nut.

Place the flat washer and spacer bushing from the stop plate kit onto the remaining 3/4 inch hex bolt, then complete the lift mechanism assembly by bolting the lift cylinder rod, lower links and two shim washers between the upper links.

Bolt through the upper set of bottom holes in the upper links for most vehicles, then secure the assembly with the 3/4 inch lock nut from the stop plate kit. Bolting through the lower set of holes will increase downward plow travel for taller trucks, but reduce lift height.

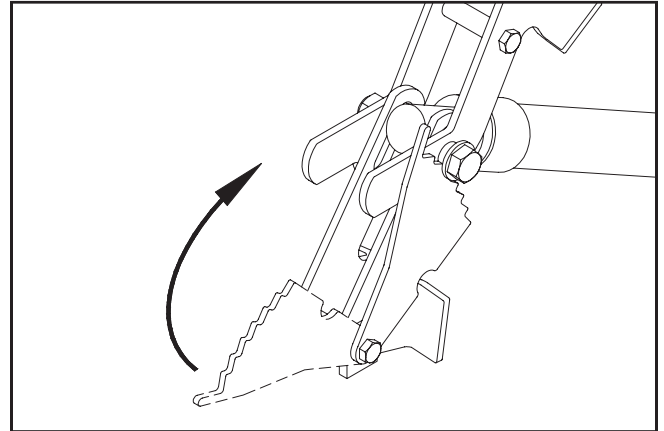

DWG NO. 6004

Rotate the stop plate up to contact the spacer bushing on the lift cylinder bolt. Gently push back on the upper lift frame tube, then release to allow the weight of the frame to lock the stop plate in place.

5. Before assembling the power unit on the lift frame, scrape a small amount of paint from the two mount holes in the lift frame to provide a good electrical ground for the turn signals and parking lights.

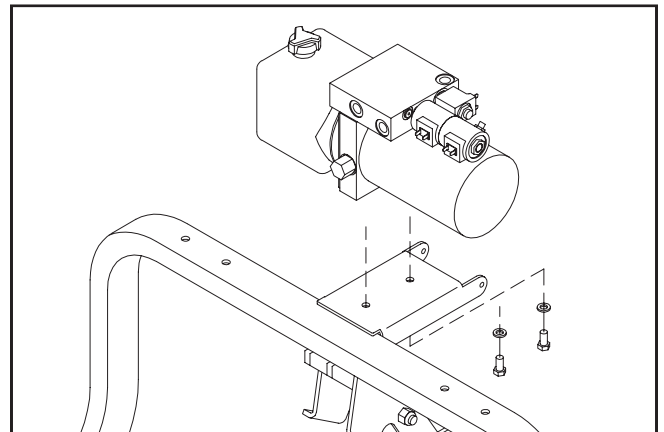

DWG NO. 6595

Mount the power unit on the lift frame with two 3/8" x 3/4" hex bolts and two 3/8" lock washers. The plastic reservoir of the power unit should be to the left side of the plow.

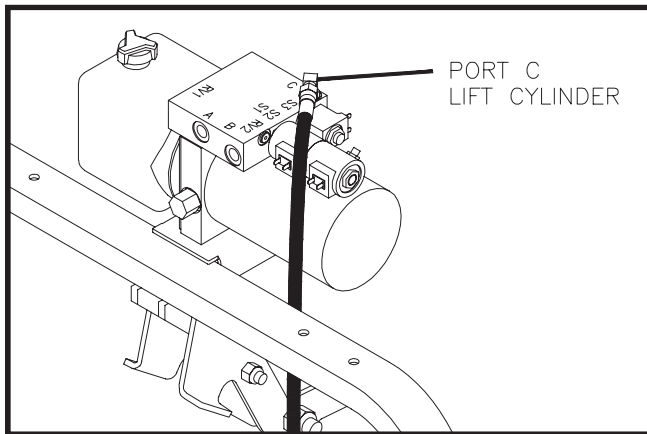

DWG NO. 6484

Locate three 90° O-ring/flare adapters in the hardware bag. Turn the O-ring end of one adapter into the top port (Port C) of the power unit so that it points about 45° to the right and to the rear when viewed from the top.

Turn the other two 90° adapters into ports A and B from the back of the power unit so that the flare ends point at opposite 45° angles from center. See drawing 6485.

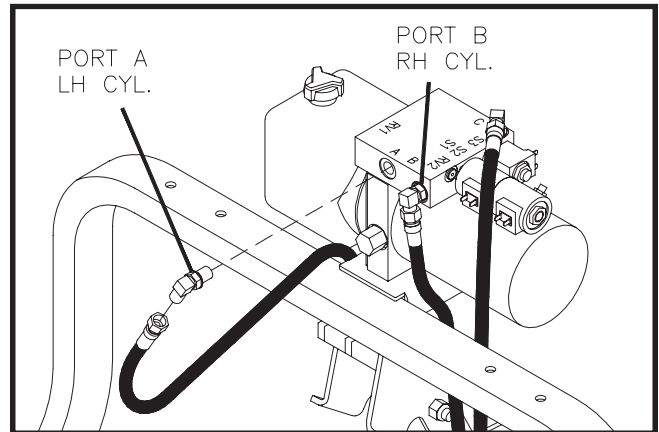

DWG NO. 6485

Connect the remaining two hoses to the fittings from ports A and B at the back of the power unit. Route both hoses ahead of the lift frame tube before assembling the hose from port A to the LH side angling cylinder and the hose from port B to the RH side angling cylinder.

The fitting on the LH side angling cylinder may have to be adjusted slightly to route the hydraulic hose to best avoid interference with the latch handle and the lift links.

Use plastic tie straps to secure all hydraulic hoses away from lift link stops.

6. Before assembling the headlamp brackets on the lift frame tube, scrape a small amount of paint from the three holes in each bracket and from the four holes in the frame tube to provide a good electrical ground for the turn signals and parking lights.

Mount the headlamp brackets to the lift frame tube with four 3/8" x 2" carriage bolts and flanged lock nuts from the hardware bag in the parts box.

Remove the LH and RH headlamps from their boxes and mount on the brackets with hardware from the headlamp boxes.

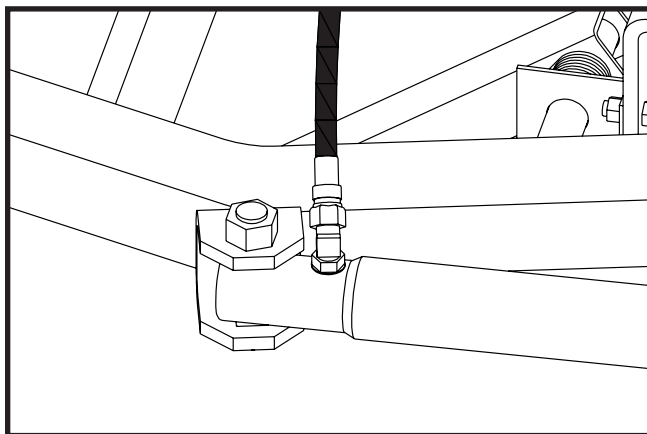

DWG NO. 4205

Install 45° O-ring/flare adapters into the ports of the angling cylinders so that the flare ends are nearly parallel to the mount lugs of the push frame.

Three identical hydraulic hoses are in the parts box. Each hose has a swivel nut on each end that will assemble to the adapters from the power unit and three cylinders.

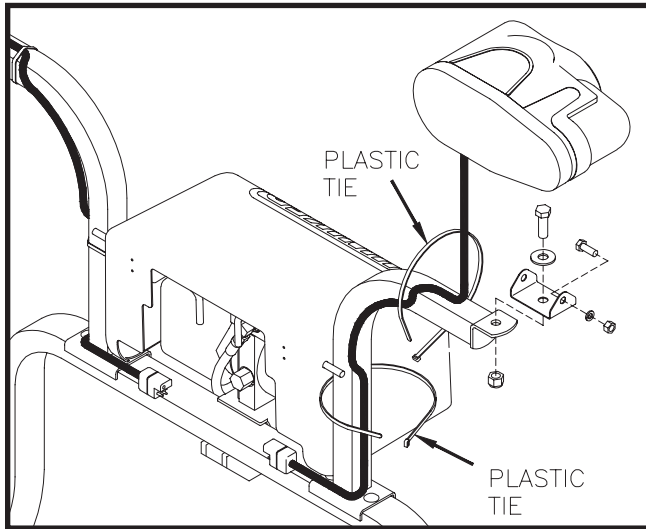

DWG NO. 6312B

Use plastic tie straps to band headlamp cables above and below the brackets at the locations shown to provide clearance for the power unit cover later.

Refer to sections titled “System Check-Out” and “Headlamp Aiming Procedure” in this manual for aiming instructions.

7. Identify the plow power cable assembly and plow wiring harness in the parts box. A ground wire harness for the solenoids is in the power unit box.

The power cable for the snowplow has two cables with ring terminals on one end and a two pin connector on the other and measures about 38” long.

The plow wiring harness has a 10-pin connector on one end and the other end has connectors labeled “DRIVER SIDE” and “PSNGR SIDE” for the headlamps and four loose wires with spade terminals.

The ground wire for the solenoids has one wire 7 inches long and two wires 11 inches long. There is a 1/4 inch ring terminal on the common end and three spade receptacles on the remaining ends.

NOTE: To prevent corrosion apply a light coat of dielectric grease to all electrical connections including ring and spade terminals.

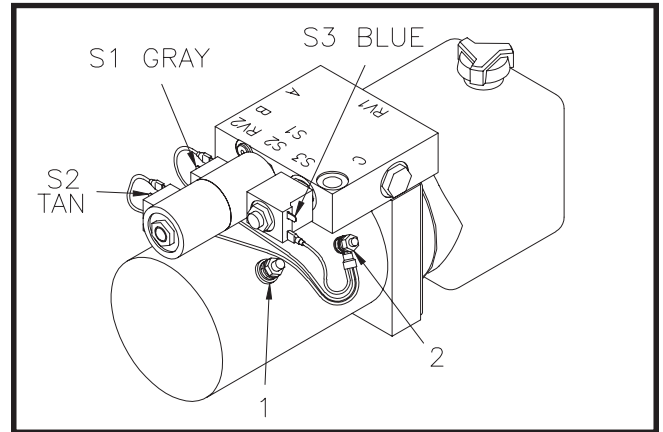

DWG NO. 6502

Refer to drawing 6502. Attach the ring terminal of the solid red (or red-striped) wire of the power cable assembly to the terminal on the power unit at location 1.

Fasten the ring terminal of the solid black wire of the power cable assembly, the ring terminal on the black wire of the plow harness and the ring terminal of the solenoid ground wire harness to the terminal on the motor at location 2.

Connect the three black wires of the ground harness to solenoids S1, S2 and S3.

Connect the gray wire from the wiring harness to solenoid S1. S1 extends the right side of the plow to plow left.

Connect the tan wire from the wiring harness to solenoid S2. S2 extends the left side of the plow to plow right.

Connect the blue wire from the wiring harness to solenoid S3. S3 lowers the plow.

Connect the RH headlamp to the wiring harness end labeled “PSNGR SIDE” and the LH headlamp to the end labeled “DRIVER SIDE”.

Ensure connections are fully mated for proper sealing. There should be no gaps between connector halves. Secure these cables to the frame with plastic ties.

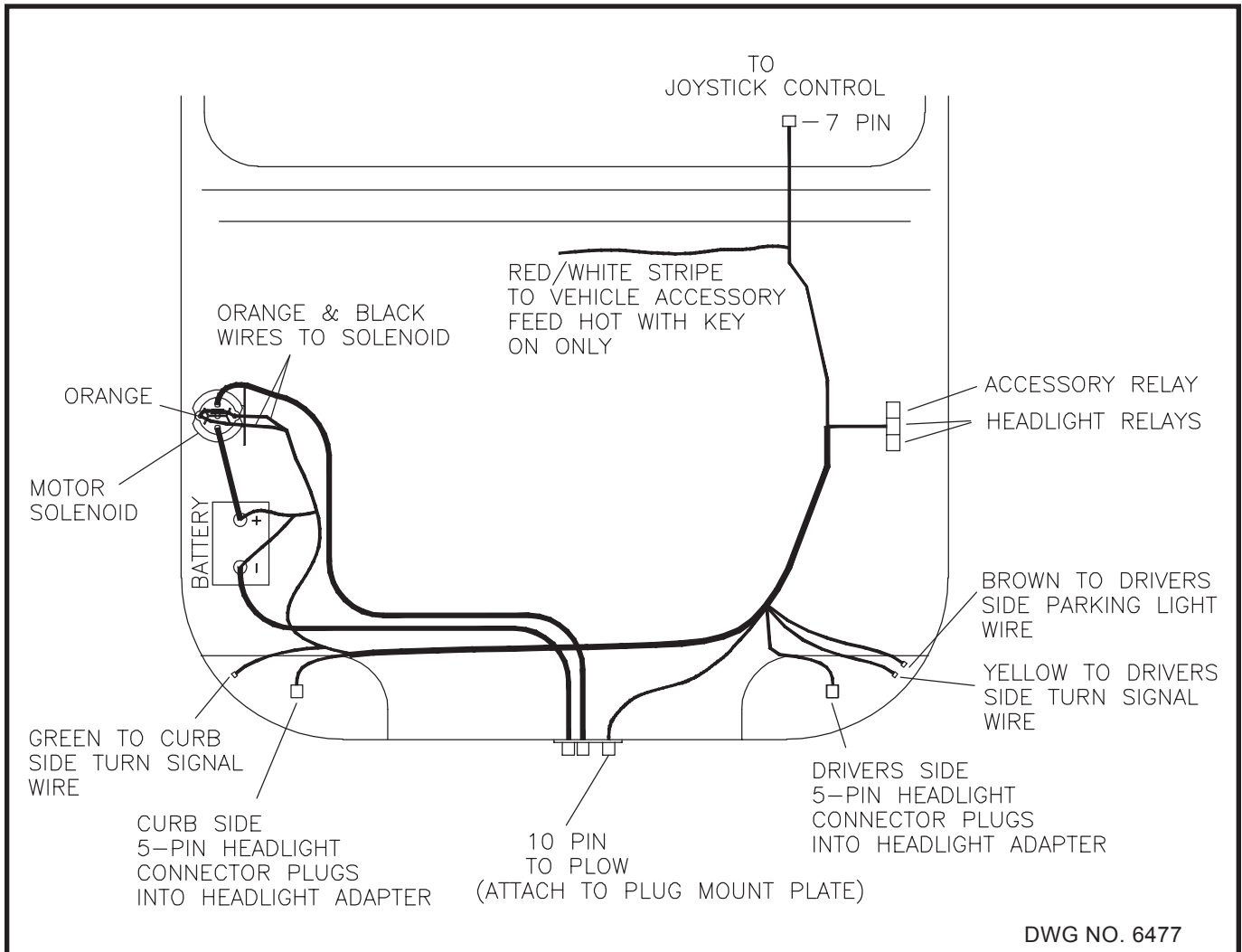

Truck Battery On Passenger Side



WARNING: Disconnect truck battery before beginning electrical installation to avoid shock hazard.

The motor solenoid, underhood wiring harness, power cable and joystick control box are located in the parts box shipped with the snowplow frame.

NOTE: To prevent corrosion apply a light coat of dielectric grease to all electrical connections including ring and spade terminals.

8. Refer to drawing 6477. Lay the harness in it's approximate position for final assembly with the 7-pin circular connector near the drivers side firewall, the 10-pin connector just left of center near the grill, the relays near the drivers side inner fender and the 5-pin headlight connectors at the respective headlights.

9. Determine the location of the vehicle battery. If the battery is located on the right (passenger) side or if there are two batteries configured as a 12 volt system, then proceed to step 10. If the battery is located on the left side of the vehicle, then the wiring harness will need to be modified.

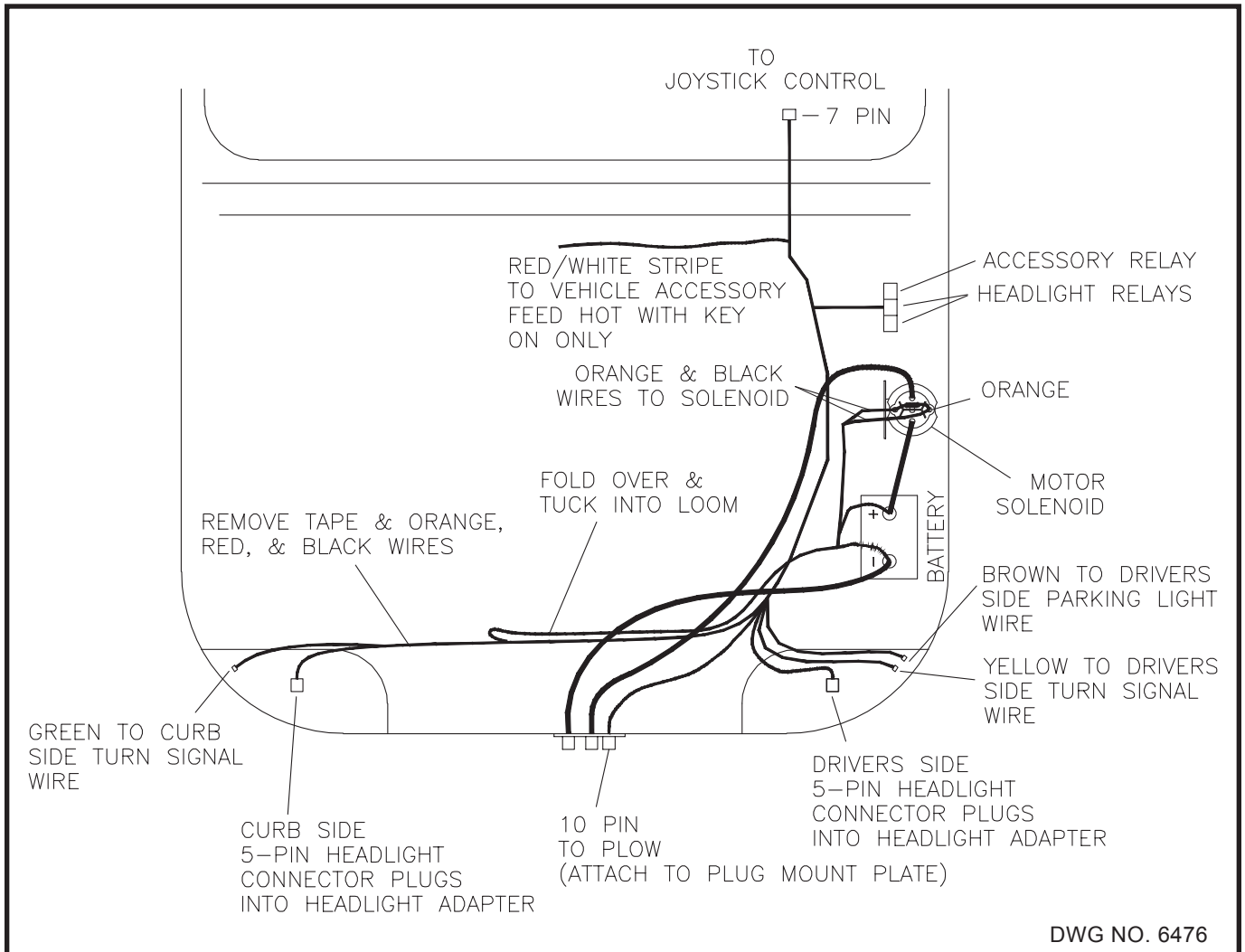

Truck Battery On Driver Side

Refer to drawing 6476, Remove the tape from the Black corrugated loom at the points shown. Locate the Orange, Red, and two Black wires. These wires connect to the battery and motor solenoid located next to the battery. Remove the four wires from approximately 33 inches of the loom, making sure the Red and Black wires are long enough to connect to the battery. Tuck these wires back into the loom as shown in the drawing and retape the loom.

10. If there is no access hole in the drivers side firewall then drill a 1-1/8 inch diameter hole. Route the 7-pin circular connector through the firewall into the cab compartment and install the 4 inch grommet in the hole, if required.



CAUTION: Ensure that the relays will clear any hood lift/spring mechanisms before installation.

11. Select an area near the drivers side fender for the relays. Drill three 1/8 inch diameter holes and secure the relays with #8 x 1/2" self-tapping screws from the hardware bag in the parts box.
12. Splice the red with white stripe wire to the vehicle's switched 12 volt auxiliary electrical circuit. This will prevent operation of the plow without the vehicle key being on. This wire controls the accessory relay that powers the control joystick and solenoids.
13. Connect the joystick control box to the 7-pin connector inside the truck cab. Secure the box at a safe location in the cab with the strip of hook and loop fastener.

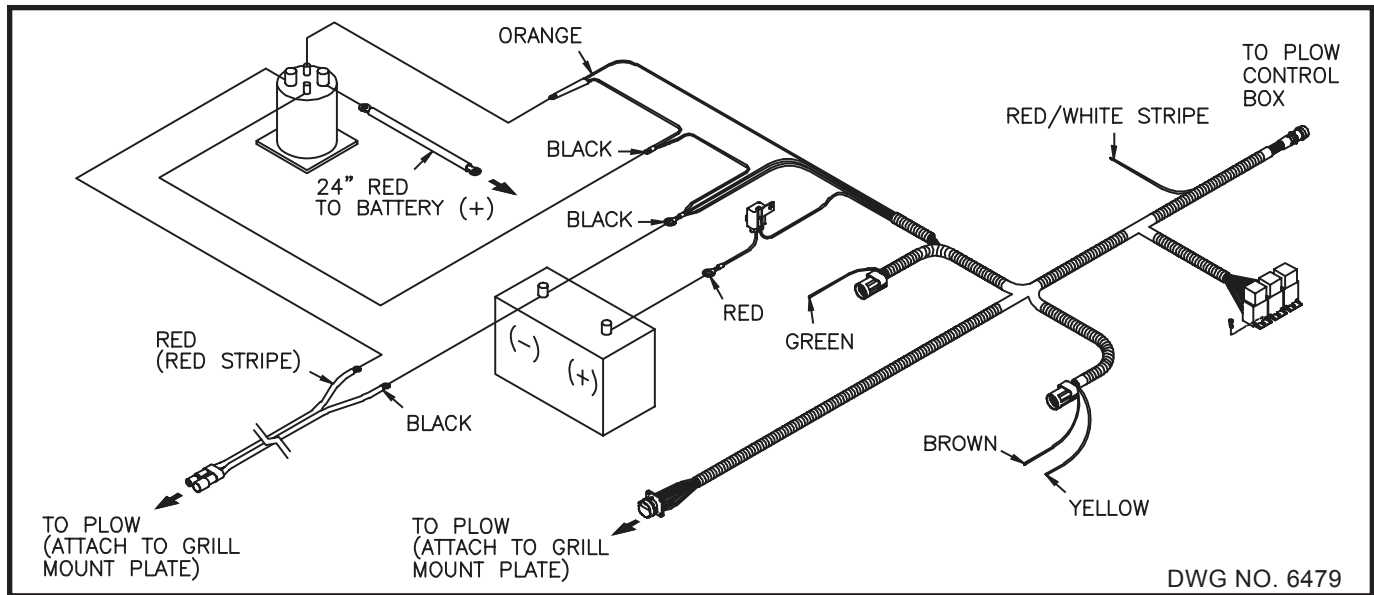

WARNING: Ensure that the motor solenoid and associated wiring will clear any hood lift/spring mechanisms before installation.

IMPORTANT: Do not over tighten nuts on the motor solenoid terminals. Over-tightening causes premature solenoid failure. Refer to torque specifications on the solenoid.

Connect the red fused wire from the harness and the 24 inch Red cable to the plus (+) terminal of the battery or battery access post. Connect the other end of the 24 inch Red cable to the motor solenoid.

14. Select an area within 16 inches of the vehicle battery for the motor solenoid. Using the solenoid as a template, mark then drill two 3/16 inch diameter holes and fasten the solenoid with two 1/4" x 1/2" long self tapping screws from the hardware bag in the parts box. Connect the Black wire to one of the small posts on the solenoid, connect the Orange wire to the remaining small post, polarity is not important.
15. Safely route the 10-pin circular connector through the grill of the vehicle to a location that will be easily accessible with the plow attached.
16. Refer to drawing 6479. Install the underhood power cable by first connecting the Black cable and the two Black wires from the harness to the minus (-) post of the vehicle's battery. Connect the Red (or Red striped) cable to the motor solenoid. Route the power cable to the grill near the 10-pin connector.

17. Remove the plug mount plate, kit from the hardware bag in the parts box.

Refer to drawing 3900. Fasten the power cable connector to the clamp by inserting the #6 x 1" machine screw through the small hole in the connector, then through the center hole of the clamp. Secure the screw with a #6 lock nut.

Fasten the clamp to the mount plate with the two #10 x 1-1/2" machine screws and #10 lock nuts supplied.

Mount the 10-pin circular connector to the mount plate with four #6 x 1/2" screws and lock nuts such that the tab on the connector will be up, as shown.

Assemble the mount plate and connector covers to the vehicle grill with plastic ties.

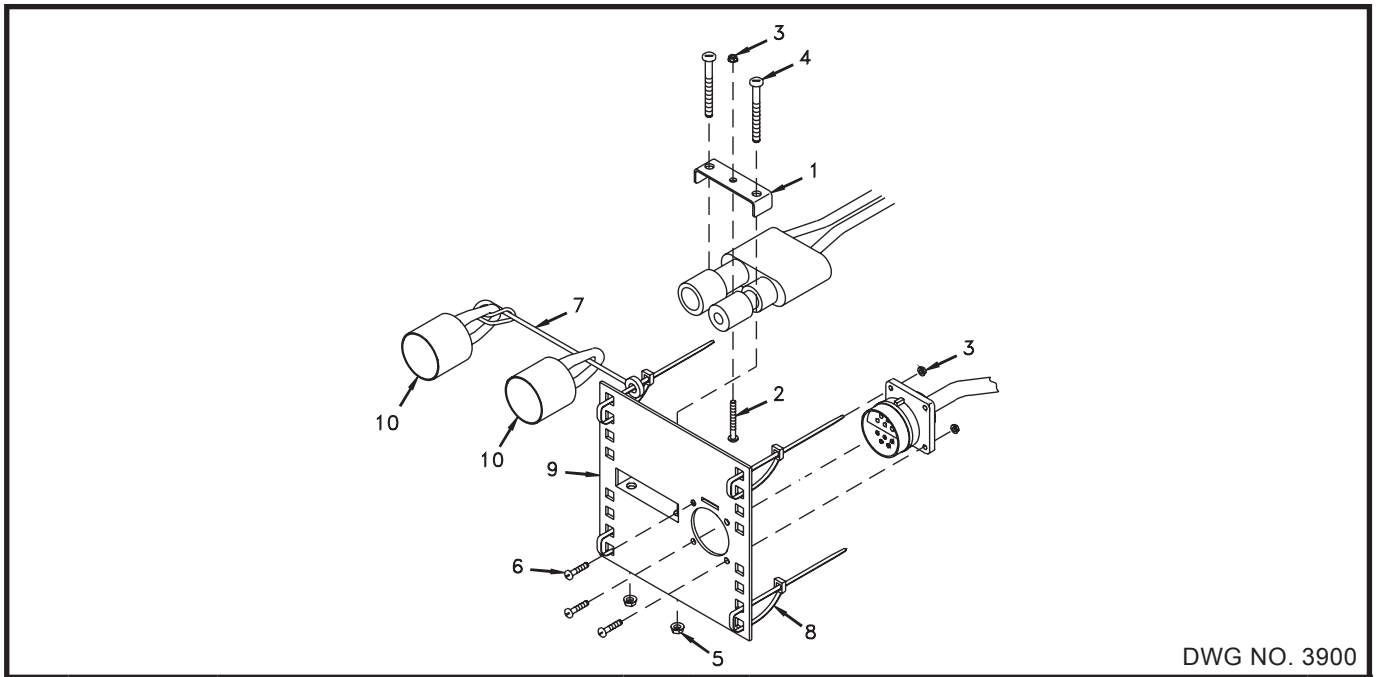

DWG NO. 3900

REF. NO.	PART NUMBER	DESCRIPTION	QTY.	REF. NO.	PART NUMBER	DESCRIPTION	QTY.
1	25011037	Clamp	1	6	950-004-033	Machine Screw #6 - 32 X 1/2"	4
2	700-10904	Machine Screw #6 - 32X 1"	1	7	36716025	Nylon Lanyard 8"	1
3	951-003-014	Locknut #6 - 32 Nylon Insert	5	8	367-001-011	Cable Tie 14"	4
4	950-004-076	Machine Screw #10 - 24 X 1 1/2"	2	9	2510278	Plug Mount Plate	1
5	392-010-010	Locknut #10 - 24 Nylon Insert	2	10	36716002	Dust Cap	2

18. Locate three blue connector splices in the hardware bag in the plow's parts box.

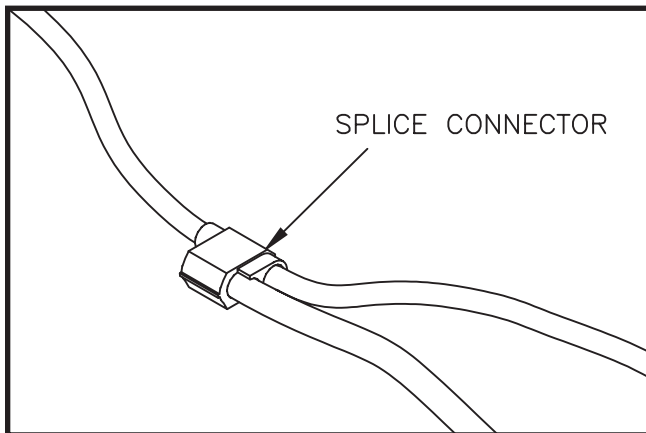

DWG NO. 4165

Using a blue splice, crimp the single brown wire from the underhood harness into the vehicle's driver's side parking light wire.

Using a blue splice, crimp the single yellow wire from the underhood harness into the vehicle's driver's side turn signal wire.

Using a blue splice, crimp the single green wire from the underhood harness into the vehicle's curbside turn signal wire.

19. Select the proper headlight adapter for your vehicle, specific instructions are included with each kit.

The headlight adapter kit consists of two identical adapters. Install the adapters according to the instructions included with the kit and connect to the 5-pin connectors of the underhood wiring harness.

20. Secure all cables away from hot or moving components with cable ties.

This completes the Electrical Installation.

21. At this point, the mount kit should be assembled onto the truck.

Prongs from the truck mount kit should be at a height that will slightly lift the plow frame when attaching the plow. Prong receivers on the plow frame should be parallel to the ground when attaching the plow. Apply powered graphite on the truck prongs to help the plow to slide on and off more easily.

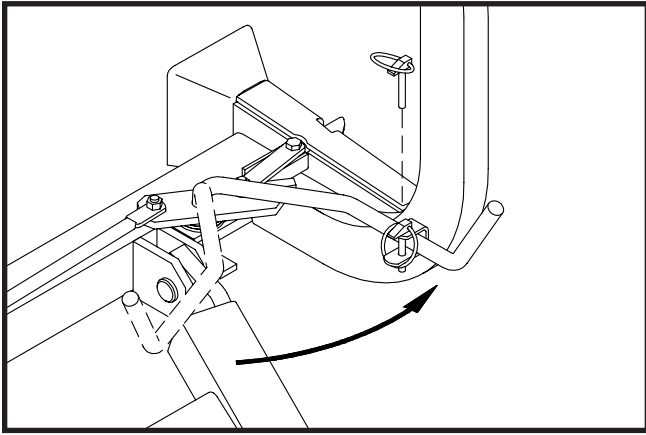

Handle Pinned With Plow on Truck DWG NO. 4199

Attach the plow onto the truck by driving the truck prongs into the receivers on the plow frame. Pull the latch handle into the frame clevis to move sliders through the notches in the prongs and receivers. Pin the handle in the clevis with its klik pin.

Raise the parking stand to its highest position and repin.

Connect the two electrical cables from the plow to their corresponding receptacles on the truck.

Select Hiniker Cold Flow Hydraulic Oil or an equivalent oil that meets military specification 5606, for plowing in extremely cold temperatures.

Pour hydraulic oil into the power unit oil reservoir until the reservoir is half full. Angle the plow full left or right to fill the angling cylinder with oil, then add more oil until the oil reaches the fill line - about 1 1/4 inches from the top. Do not overfill the oil reservoir.

Cycle the plow left and right and up and down to purge any air trapped in the system.

Check the oil level with the plow on the ground. Add oil to the fill line, if necessary, but do not overfill the reservoir.

NOTE: New hydraulic cylinders will leak a small amount of oil until packings become saturated and produce a good seal. If leakage is exces-

sive, or if leaking continues after initial cycling, tighten the cylinder packing nut in 1/8-turn increments until leaking stops.

22. Fasten the power unit cover to the lift frame bracket with two 1/4" x 3/4" screws, flat washers and lock nuts from the hardware bag in the parts box. Tighten the lock nuts so that the assembly is secure, yet the cover hinges freely.

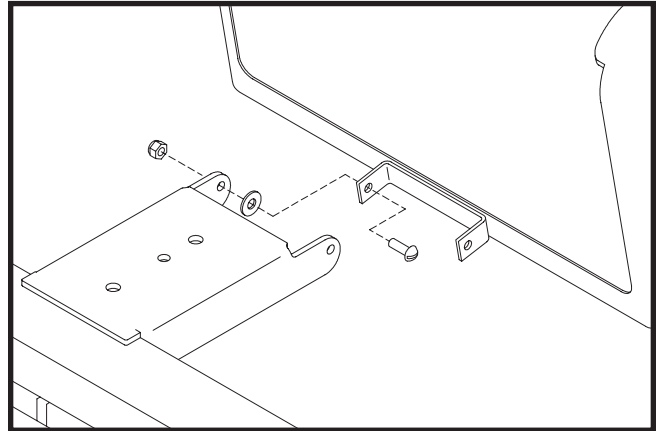

DWG NO. 6310

When the cover is closed, rods from the latch handles should extend behind the light brackets to hold the cover in place.

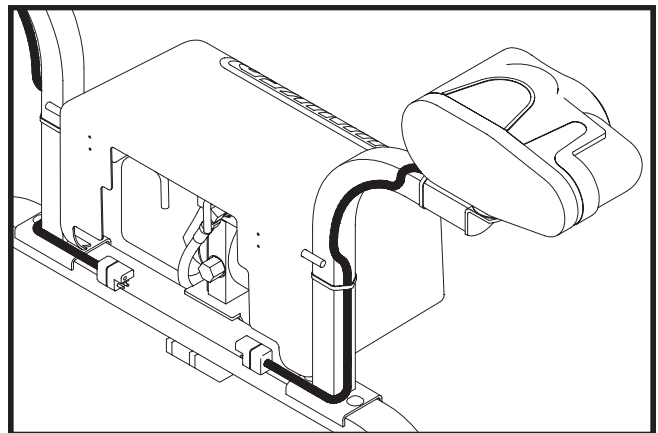

DWG NO. 6070A

23. Unbolt the side markers from the top of the moldboard. Attach them to the end moldboard ribs with the removed 5/16" x 3/4" hex bolts and lock nuts.

SYSTEM CHECK-OUT

NOTE: The two-conductor high-current connectors between the plow and the truck must be connected to check out the plow and truck lights and the hydraulic motor/valve assembly.

1. Connect the 10-pin connector to the plow. Move the headlight switch on the joystick control box to the "TRUCK" position. Turn on the headlights. The truck lights should operate in both high and low beam.
2. Place the headlight switch on the joystick control box in the "PLOW" position. Turn on the headlights, the plow lights should now operate in both high and low beam positions and the truck headlights should be off.
3. With the 10-pin connector connected to the plow, test the parking lights and both turn signals. Both truck and plow parking and turn signals should operate at the same time. On the plow, the parking lights are a single light and the turn signals are dual lights.
4. With the 10-pin connector connected to the plow, test the operation of the joystick control box and hydraulics assembly. Assure that the plow assembly is free to move up/down and side to side and that all bystanders are clear.

If the blade angles opposite to that desired by the operator, exchange the tan and gray wires on the pump valve.

JOYSTICK CONFIGURATION

NOTE: This section only applies to joysticks with serial numbers starting with "SR" (drawing 5714 location 1). These joysticks have a replaceable / reversible 4-way switch.

Refer to drawing 5714 for location and positioning information.

The joystick may be configured to alternately RAISE the plow by pressing the 4-way switch forward. The factory default is the plow LOWERS when pressing the switch forward.

View the RAISE and LOWER direction indicators on the decal at location 2 and determine if the indicators are positioned properly for your RAISE and LOWER preference. To change the direction indicators for RAISE and LOWER the decal may be turned over.

Using a small screwdriver at location 3, pry the reversible decal away from the side to disengage the retaining tabs from the top case. The decal may now be turned over and reinserted into the top case. Reinsert the decal by gently squeezing the long sides together enough to allow the four tabs to slide into the slots in the top case.

To reverse or replace the 4-way switch you must first remove the 4 screws indicated at location 5, and separate the case from the circuit board assembly. The 4-way switch assembly (Item 4) has a small circuit board that is attached to the main circuit board through a 5-pin inline connector. To separate the connector, gently grasp the small circuit board and pull it away from the main circuit board.

To install the 4-way switch assembly, first select the proper orientation required based on your RAISE and LOWER preference that was determined previously. Refer to drawing 5709 to determine the proper orientation of the switch assembly. There are two connectors on the assembly, only one of which will be connected to the main circuit board. The other will not be used. Gently mate the proper connector on the switch assembly to the mating pins on the main circuit board.

Insert the complete control assembly into the top case making sure the 4-way switch is properly seated and the strain relief on the wire harness is inside the case. Route the wires such that they will not be pinched between the bosses when assembling. Reassemble the case halves together and install the 4 screws.

DO NOT force the case together. Check for proper alignment.

Connect the joystick to the plow or a snowplow tester and determine that the RAISE and LOWER indicators on the top decal match the movement of the plow when activated.

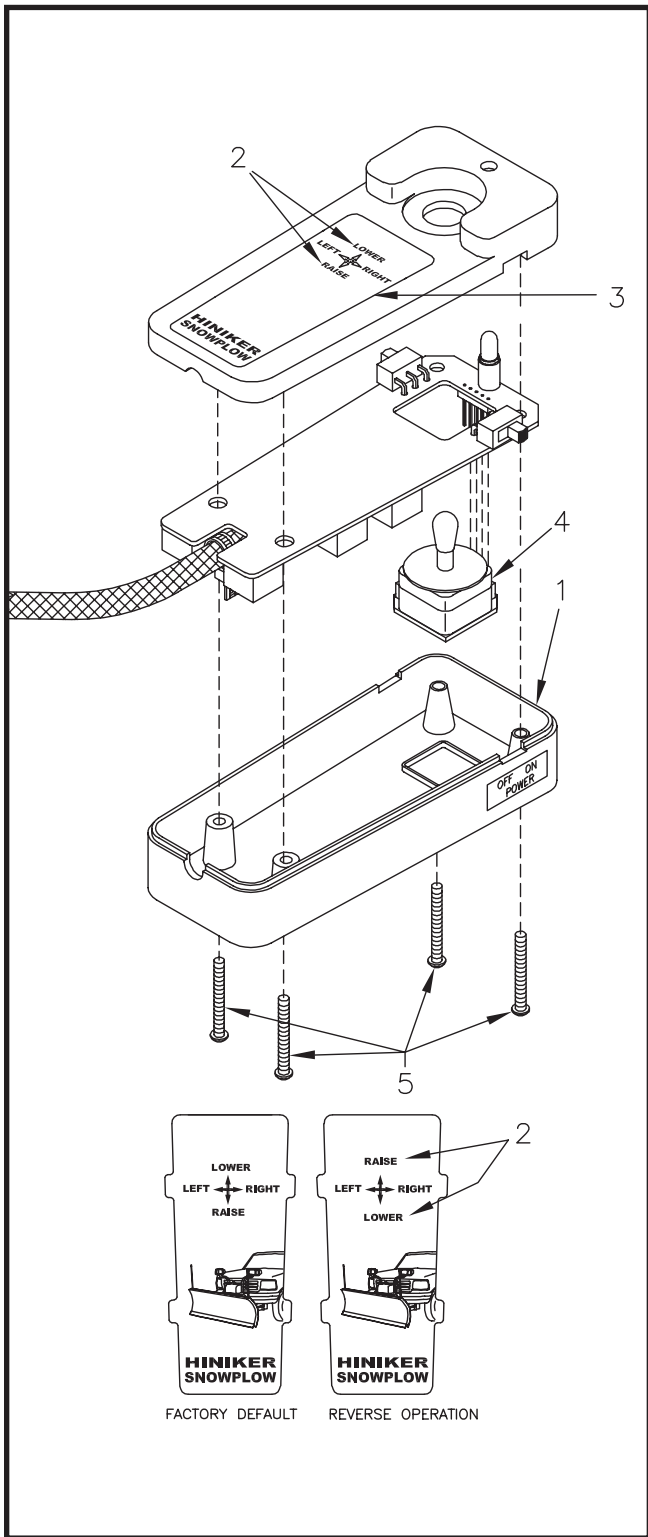

DWG NO. 5714



Failure to have the decal match the plow's actions may cause unintentional movement thereby causing an accident or injury.

Replacement switch assemblies are available from your Hiniker dealer. Request part number 36014019.

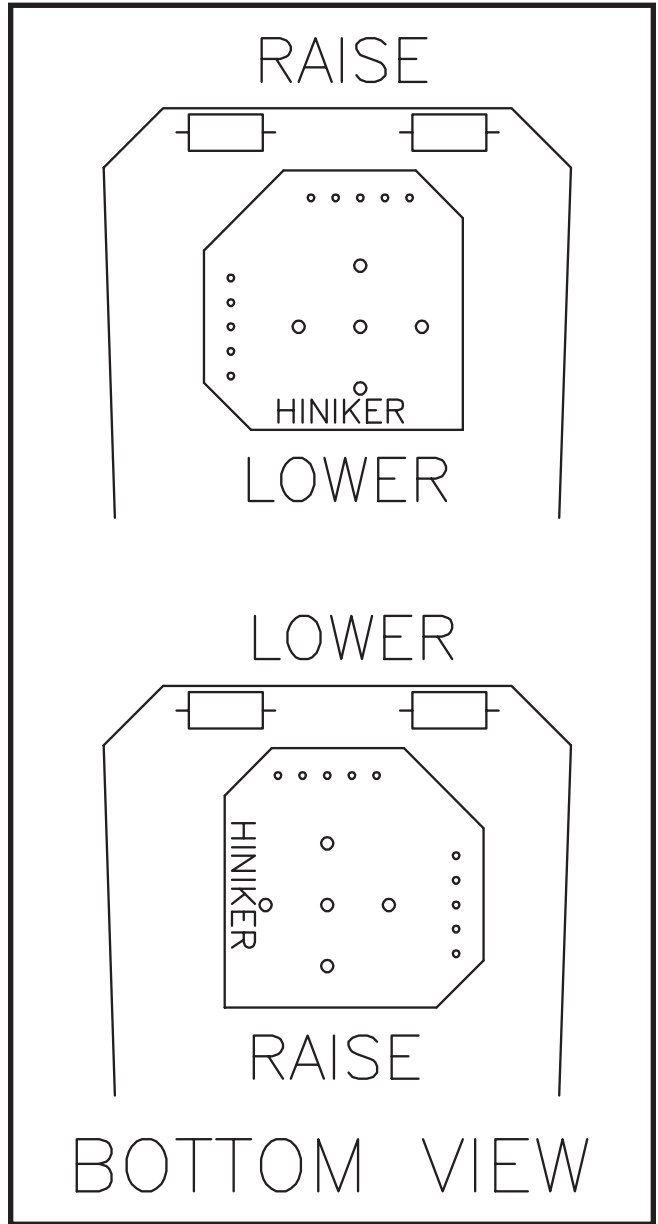

DWG NO. 5709

HEADLAMP AIMING PROCEDURE

1. Park the vehicle with the plow attached on a level surface 25 ft (7.6 m) from a flat, unobstructed light-colored wall.

With no load on the vehicle other than the driver, snowplow and rear ballast weight, inspect the vehicle for proper tire inflation and broken or sagging suspension components. Check functioning of any automatic vehicle leveling systems and any specific manufacturer's instructions pertaining to vehicle preparation for headlamp aiming. Stabilize the suspension by rocking the vehicle side-ways.

2. Mark a vertical line (line 1) on the wall with black tape, or other means, directly ahead of the center of the vehicle.

Mark two additional vertical lines (lines 3 and 4) offset 20 1/2 inches (52 cm) from the first line representing the distance between the two plow headlamps.

3. Measure the height from the ground to the center of the plow headlamps, then mark a horizontal line (line 2) on the wall at that same height.

4. Refer to the following chart then mark a second horizontal line below the first (line 5), as required.

Headlamp Centerline Height	Vertical Aim Down
22 to 36 in (56 to 90 cm)	0
36 to 48 in (90 to 120 cm)	2 in (5 cm) Down
48 to 54 in (120 to 140 cm)	4 in (6.4 cm) Down

5. Wipe the lamp lenses clean and check for proper switching and function.

Activate the plow lamp HIGH beams to illuminate toward the wall. Focus the center of the LH light beam on the intersection of lines 3 and 5. Focus the center of the RH light beam on the intersection of lines 4 and 5.

Tighten the headlamp mounting hardware to 70 ft.-lbs. (95 N-m) maximum to hold the headlamps in position.

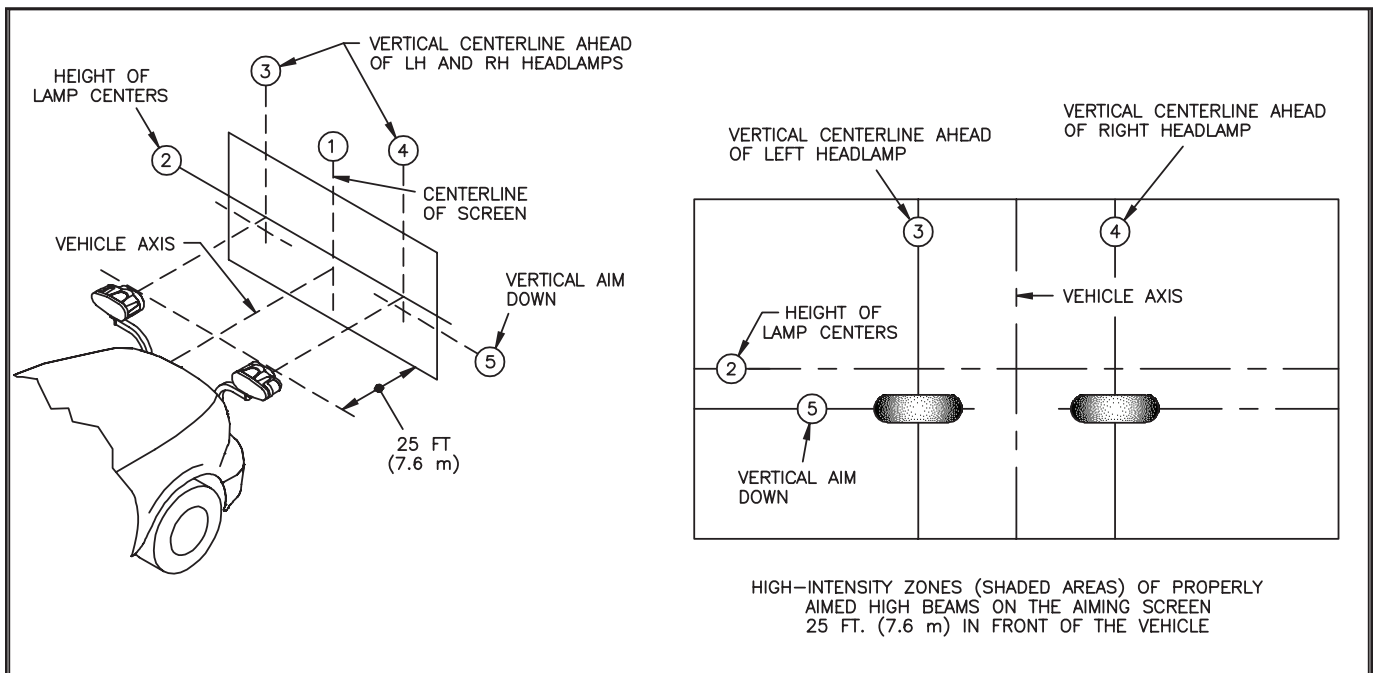

CAB CONTROL

J1

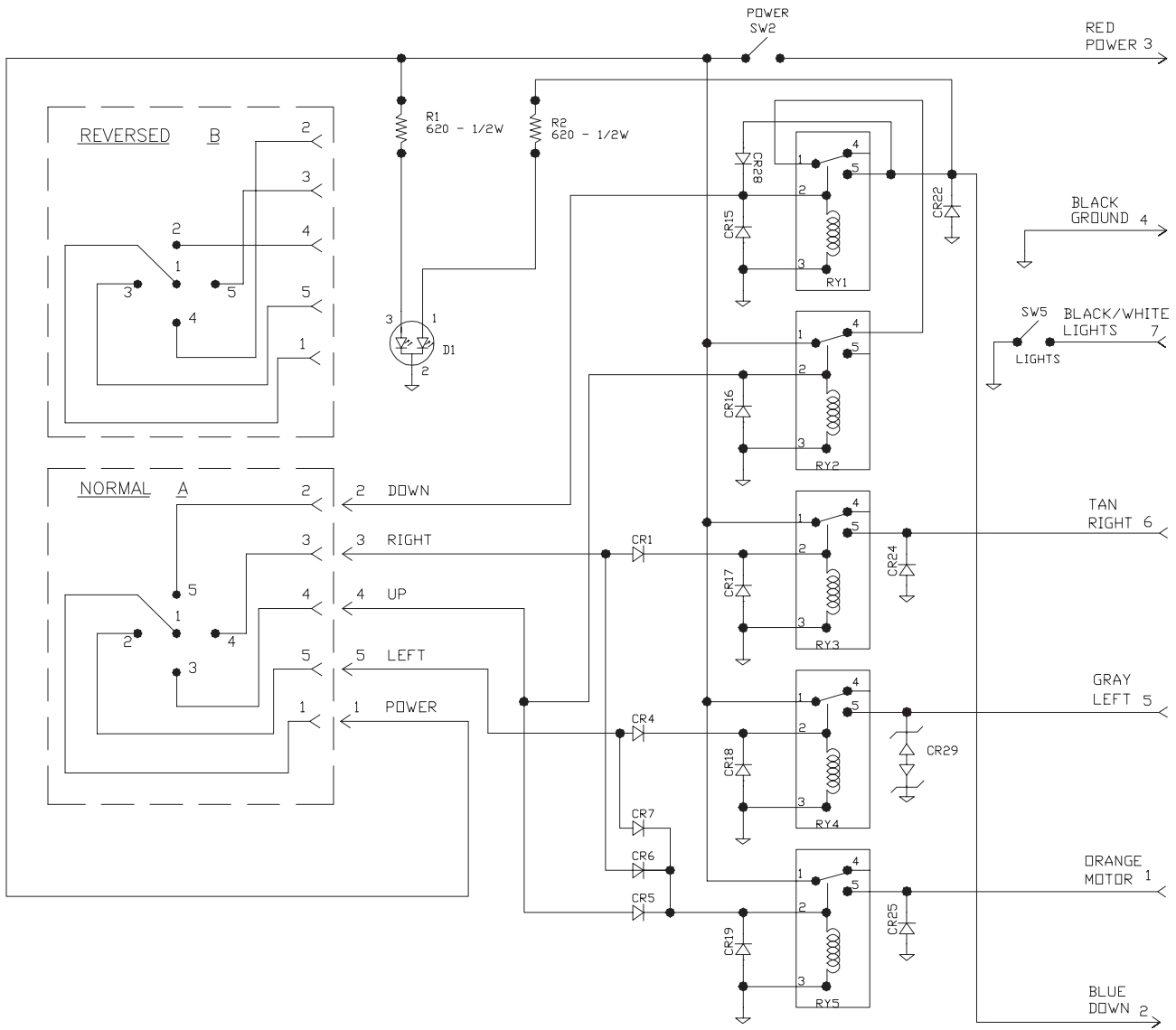

UNDERHOOD HARNESS

EXTERNAL HARNESS

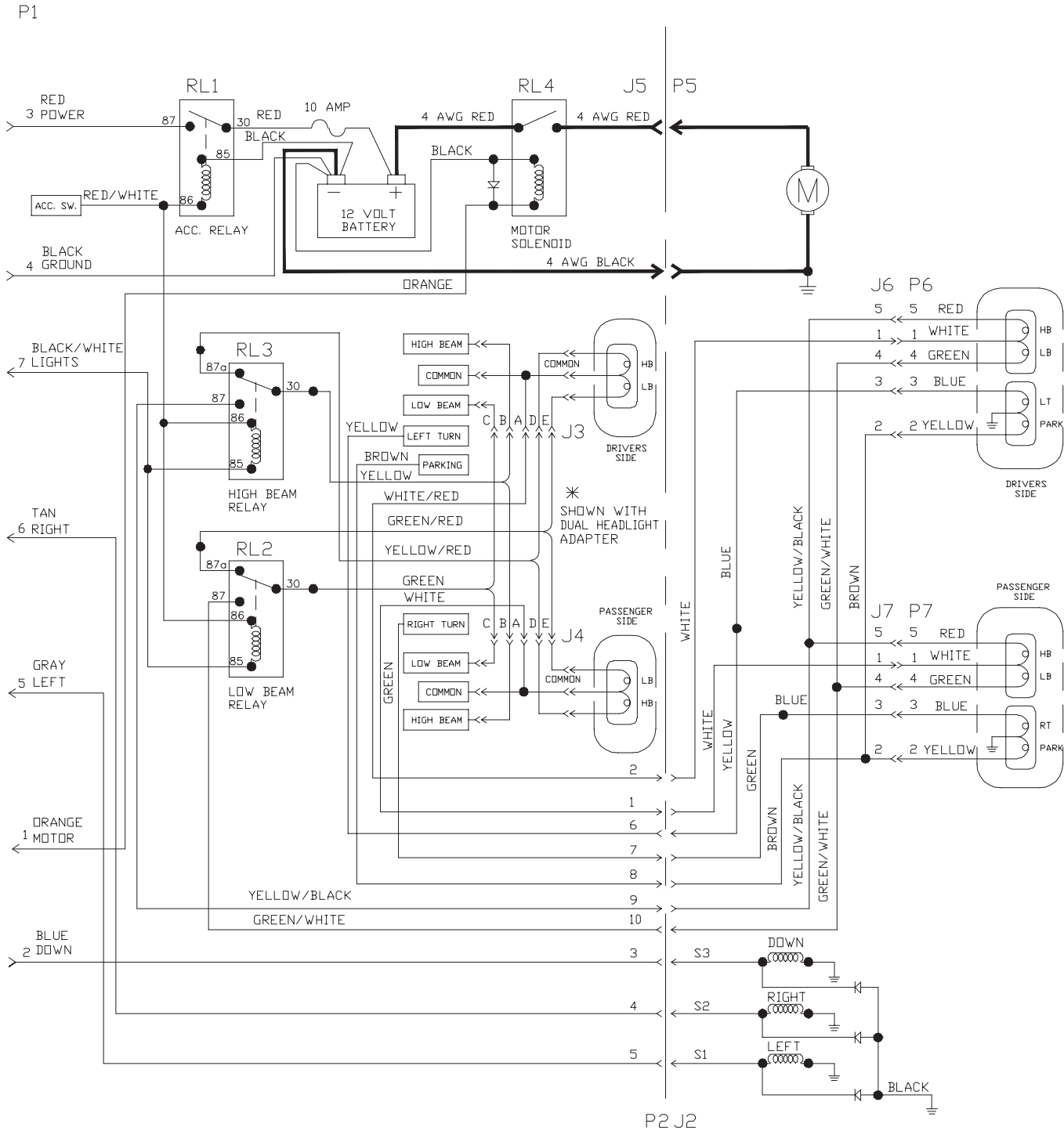

DWG NO: 5657
DATE: 3-24-05
STR PLOW 2005

DWG NO. 5657

STRAIGHT FLOW POWER UNIT

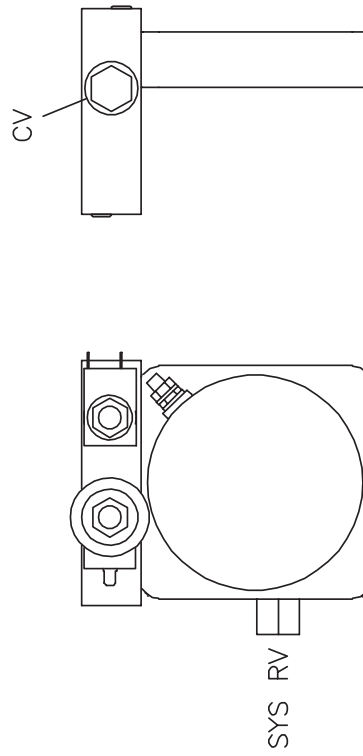
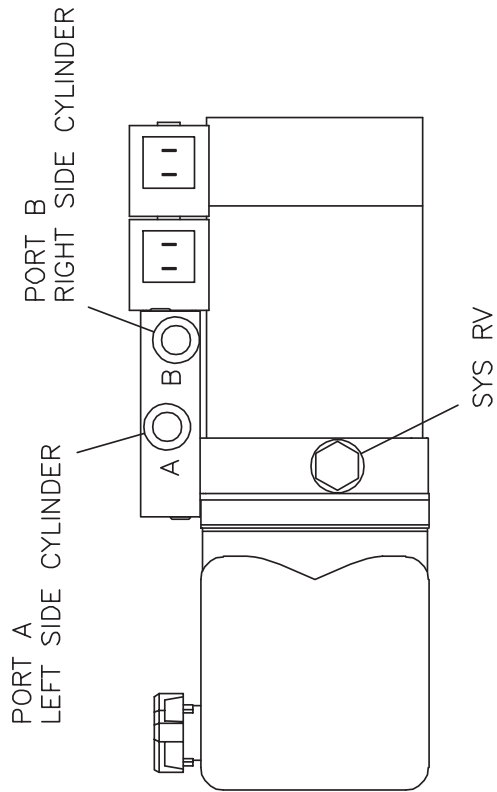
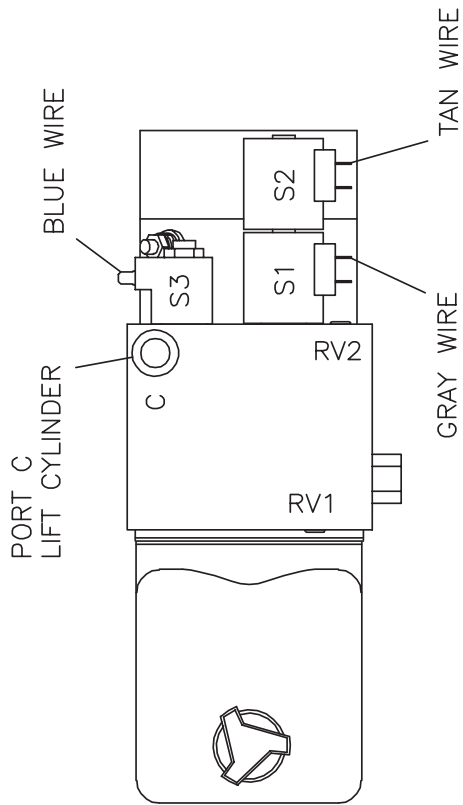

RV1 - RELIEF VALVE, RIGHT SIDE CYLINDER, 2500 PSI
 RV2 - RELIEF VALVE, LEFT SIDE CYLINDER, 2500 PSI
 SYSRV - RELIEF VALVE, SYSTEM, 2400 PSI

POWER UNIT HYDRAULIC CIRCUIT DIAGRAM

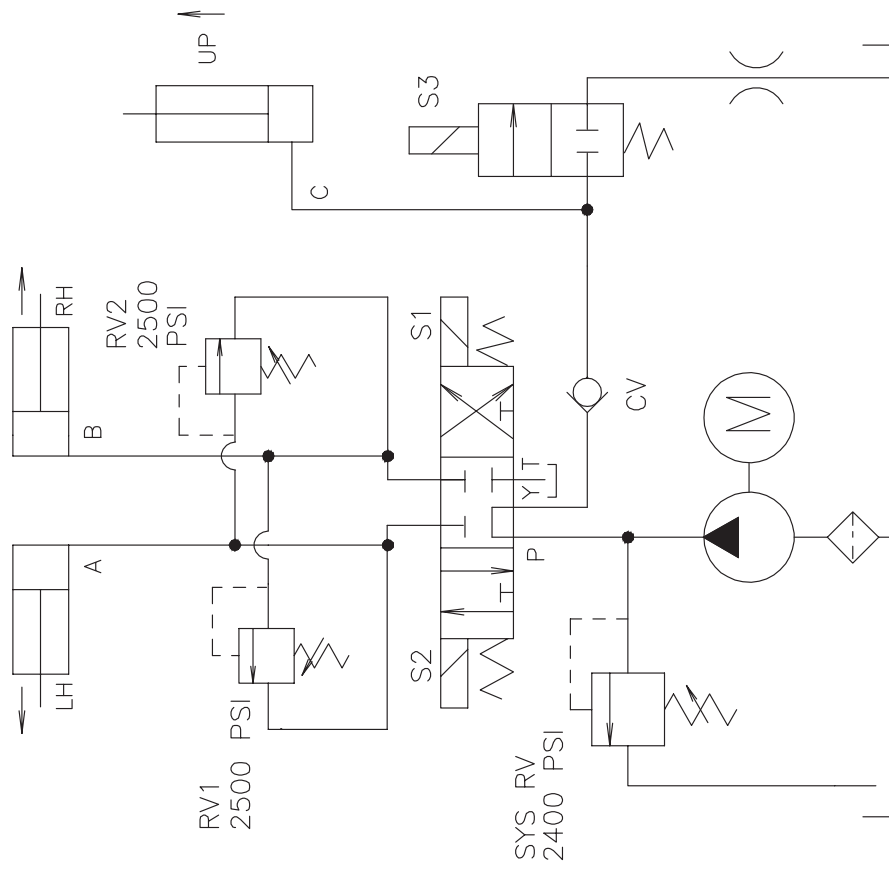

- S1 - RIGHT EXTEND - GRAY WIRE
- S2 - LEFT EXTEND - TAN WIRE
- S3 - DOWN - BLUE WIRE

SPECIFICATIONS

Blade Width	8' at pivot pin	9' at pivot pin
Plow Width at 31°	7'3"	8'1"
Blade Height	30"	30"
Cutting Edge	3/8" X 6" 1084 steel	
Weight	735 lbs.	793 lbs.
Recommended Hydraulic Fluid	Hiniker Cold Flow Mil Spec 5606 Or Equivalent	
Hydraulic Fluid Capacity	2 qts.	
High Beam Bulb	One # H1, 12V 55W	
Low Beam Bulb	One # H7, 12V 55W	
Turn Signal/Parking Bulb	One # 1157 heavy duty double contact 32/3 C.P. 12 VDC	
Motor Solenoid	12 VDC solenoid, continuous duty, sealed	
Wiring Harness Fuse	10 AMP	

HINIKER WARRANTY

HINIKER SNOWPLOW LIMITED WARRANTY

The only warranty Hiniker Company (Hiniker) gives and the only warranty that any Hiniker dealer is authorized to give on behalf of Hiniker is as follows: **(NO EMPLOYEE OR REPRESENTATIVE IS AUTHORIZED TO CHANGE THIS WARRANTY IN ANY WAY OR GRANT ANY OTHER WARRANTY.)**

Hiniker warrants to the original purchaser of a Hiniker snowplow that Hiniker will repair or replace any defects in material and workmanship that occur within two years from date of retail delivery except the following items: Hiniker warrants that it will repair or replace any defects in materials or workmanship with respect to the paint finish, any accessories, and service parts and components for a period of one year from date of retail delivery.

Hiniker's obligation and liability under this warranty is expressly limited to repairing or replacing, at Hiniker's option, at an authorized Hiniker dealer location, the defective parts at no charge to the original purchaser. **HINIKER MAKES NO OTHER WARRANTY, EXPRESS OR IMPLIED AND MAKES NO WARRANTY OF MERCHANTABILITY OR OF FITNESS FOR ANY PARTICULAR PURPOSE.**

HINIKER'S OBLIGATION UNDER THIS WARRANTY SHALL NOT INCLUDE ANY TRANSPORTATION CHARGES TO OR FROM THE AUTHORIZED HINIKER DEALER LOCATION OR ANY LIABILITY FOR INCIDENTAL, INDIRECT OR CONSEQUENTIAL DAMAGE OR DAMAGES OF ANY KIND FOR LOST PROFITS OR DELAY. If requested by Hiniker, products or parts for which a warranty claim is made are to be returned freight prepaid to our factory. Any improper use, operation beyond rated capacity, substitution of parts not approved by Hiniker Company, or any alteration or repair in such manner as in our judgment affects the product materially and adversely shall void this warranty.

Hiniker reserves the right to make improvements or changes to any of its products without notice. Such improvements or changes shall not trigger any obligation by Hiniker to update, modify or change any products previously sold by Hiniker.

HINIKER does not warrant the following:

1. Used products.
2. Any product that has been repaired, modified or altered in a way not approved by Hiniker Company.
3. Depreciation or damage caused by normal wear, lack of reasonable and proper maintenance, failure to follow Operators Manual Instructions, misuse, lack of proper protection during storage, or accident.
4. Parts replacement and service necessitated by normal wear or maintenance including, but not limited to, cutting edges, hoses, snowplow skid shoes, blade marker guides and hardware.
5. Paint finish damage caused by normal wear.

Hiniker does not assume any liability for any damage to a motor vehicle resulting from the attachment or use of a Hiniker snowplow. Compliance with applicable motor vehicle regulations is the responsibility of the installer. Attachment of a Hiniker snowplow to a motor vehicle is at the risk of the purchaser.

It is the responsibility of the original snowplow purchaser to verify the original date of purchase.

A DELIVERY REPORT FORM must be filled out and received by Hiniker with 30 days of retail delivery at the address below to initiate the warranty coverage.

HINIKER COMPANY
58766 240th St.
P.O. Box 3407
MANKATO, MN 56002-3407
PHONE (507) 625-6621 -- FAX (507) 625-5883
www.hiniker.com