



PICKUP TRUCK SNOWPLOW
Plastic Moldboard w/Trip Edge
Models 7800, 7900

OPERATOR'S MANUAL

DO NOT USE OR OPERATE THIS EQUIPMENT UNTIL THIS MANUAL
HAS BEEN READ AND THOROUGHLY UNDERSTOOD

PART NUMBER 25011425 REV A

Three thick, horizontal black bars stacked vertically at the bottom of the page.

TABLE OF CONTENTS

25011425 Rev. A

5/03

E:1054B/25011425

TO THE PURCHASER.....	2
SAFETY.....	3
OPERATING PROCEDURES.....	4
TROUBLE SHOOTING.....	8
MAINTENANCE.....	10
ASSEMBLY.....	12
SPECIFICATIONS.....	22
WARRANTY.....	Inside Rear Cover

TO THE PURCHASER

This product is designed and manufactured to give years of dependable service when properly maintained and used for the purpose for which it is intended. Never allow anyone to operate this equipment until they fully understand the complete contents of this manual. It is the responsibility of owners who do not operate this equipment to ensure the operator is properly instructed and understands the contents of this manual. It is also the owner's responsibility to ensure that anyone operating this equipment is mentally and physically capable of so doing.

Important information is contained in this manual to help ensure safe and efficient operation.

If you have any questions about this manual, or the equipment discussed herein, contact your Hiniker dealer.



This is a safety alert symbol. It alerts an operator to information concerning personal safety. Always observe and heed these instructions, otherwise death or serious injury can result.

All references to Left or Right are defined as viewing the plow from the cab of the truck.

This Operator's Manual is shipped with this equipment. Contact your Hiniker dealer for additional copies.

Always obtain original Hiniker service parts. Substitute parts could adversely affect equipment performance and warranty.

Check that your dealer has forwarded the Hiniker delivery report form along with the plow identification number because it helps maintain maximum service and warranty benefits. This does not put you on any mailing list, and information thereon is not available to others.

Your plow's identification number plate is at location (1) in the following illustration.

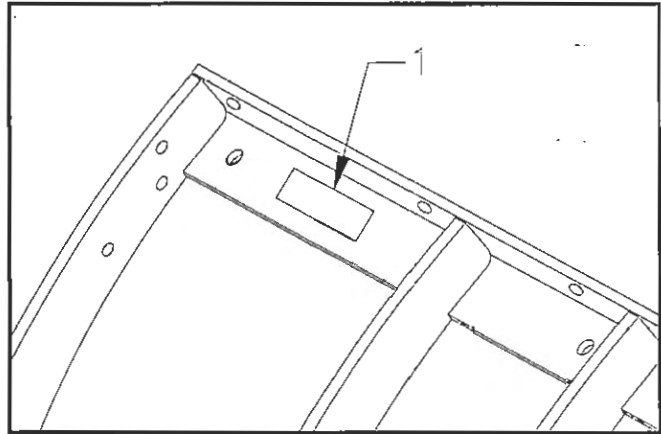

DWG. NO. 5248

Record the following information for later reference when obtaining service parts:

Purchase Date _____

Purchaser's Name _____

Dealer's Name _____

Machine I.D. No. _____

SAFETY



This is a safety alert symbol. It alerts an operator to information concerning personal safety. Always observe and heed these symbols and instructions, otherwise death or serious injury can result.

Operator safety is a principle concern in equipment design and distribution. However, many accidents occur because a few seconds of thought, and a more careful approach to handling, were ignored.

Accidents can be avoided by knowing and following the precautions cited in this manual.

GENERAL SAFETY

1. Read this manual thoroughly. Make sure the operator understands it and knows how to operate this equipment safely. This equipment can kill or injure an untrained or careless operator and bystanders. If you sell this equipment, ensure the new owner acknowledges receipt of this manual.
2. This plow is intended for plowing snow only. Plowing gravel, rocks, etc., or using the plow for any purpose other than plowing snow could result in harm to the operator or bystanders or cause damage to the plow or vehicle.
3. Do not attempt to handle or service this equipment, and direct others to do the same, unless you know how to do it safely and have the proper tools for the job.
4. Keep hands, feet, hair, and clothing away from moving parts.
5. Do not alter the equipment to the extent of compromising safety or performance.

BEFORE OPERATION

1. Discipline yourself to visually check for worn, damaged or cracked parts before starting use. Replace these with genuine Hiniker parts.

2. Escaping hydraulic oil under pressure can penetrate the skin, causing serious injury.

Do not use your hand to check for leaks. Use a piece of paper or cardboard to find suspected leaks.

Tighten all connections before pressurizing hydraulic lines.

If fluid is injected into the skin, get medical attention immediately to prevent serious infection.

3. Check all controls and operating functions of the machine in a safe area before starting to work.

DURING OPERATION

1. Always wear seat belts when operating a motor vehicle.
2. Ensure everyone is clear of the machine, especially away from blind areas of the operator, before starting, actuating hydraulics or operating this equipment.
3. Do not plow snow at excessively high speeds.
4. Avoid hitting objects that will damage your plow or truck.
5. Set the brakes and stop the truck's engine before adjusting or servicing your plow. Do not service or otherwise handle a plow in the raised position unless it is securely blocked against unexpected falling.

AFTER OPERATION

1. Park the plow on a solid, level surface. Fully collapse the lift cylinder with the upper lift links before unhitching the plow to prevent the plow frame from falling forward.

OPERATING PROCEDURES

ATTACHING THE PLOW

Attachment prongs on the truck should be mounted such that the bottom edge of the prongs measure about 10 inches above the ground. Prong receivers on the plow frame should remain parallel to the ground and at the correct height by fully retracting the lift cylinder with the upper lift links before removing the plow from the truck (see "Removing the Plow"). Ideally, the prongs on the truck should lift the plow frame slightly when driving into the plow for attachment.

Powdered graphite applied on the prongs will help the plow slide on and off more easily.

Check that prongs are in line with the receivers before slowly driving into the plow. Set the parking brake in the truck to prevent it from creeping back out from the receivers.

Remove the tab lock pin from the parking stand index plate to raise the stand to its highest position. Reinstall the pin in the plate for transport.

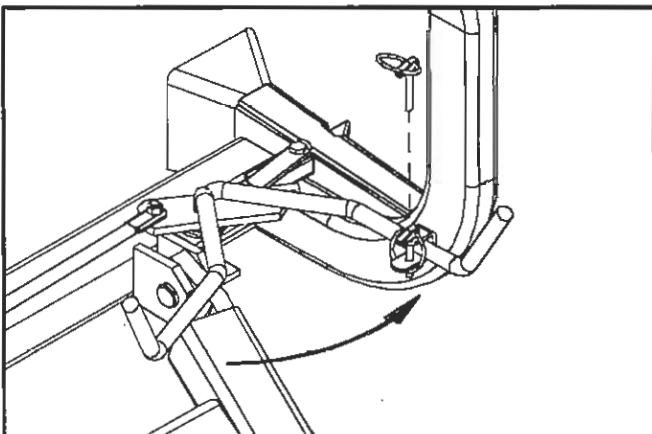

Handle Pinned With Plow On Truck

DWG. NO. 4199

Pull the latch handle into the clevis on the lift frame to force the sliders through the notches in the prongs and receivers. Pin the handle in the clevis with its klik pin. Failure to pin the handle in place may allow the plow to fall off the truck.

NOTE: Before connecting the plow's wiring to the truck, make sure power is switched "Off" on the joystick controller.

Plug in the two electrical connectors between the plow and the truck after latching the plow. The alignment tab on the 10-pin receptacle will mate with the slot in the mounting plate on the truck grill to ensure proper connection.

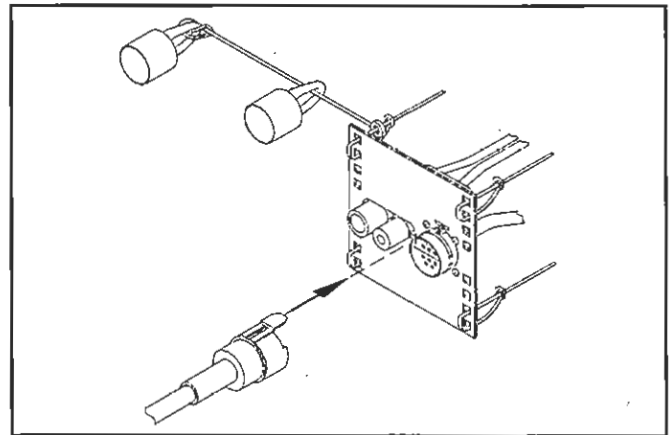

Alignment Tab and Slot

DWG. NO. 3922

Check that the plow headlamps and turn signals are operational, and headlamps are aimed correctly. Test the lift and angling cylinders in a safe area before using the plow.

To make alignment of the plow easier in the future, mark a point on the back of the head lamp, a point on the hood near the front of the truck and a point on the windshield that are in line when you are seated behind the steering wheel. Line up these three points when driving into the plow.

THE JOYSTICK CONTROLLER

The joystick control box has slide switches for controlling power to the snowplow and for switching from the truck headlights to the headlights on the plow. The joystick controller raises and lowers the plow and angles the blade left or right.

The vehicle's electrical power must be turned on before the control box will function.

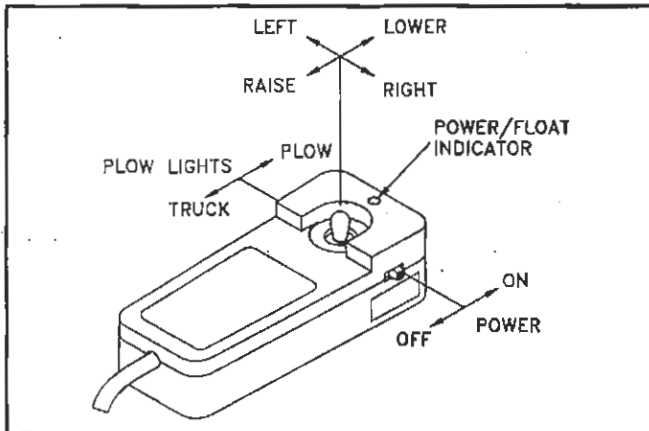

Joystick Control Box

DWG. NO. 4176

Place the on/off switch on the joystick control box in the "on" position to supply power to the snowplow. A green light will indicate power is on.

Move the headlight slide switch on the control box to the "plow" position to change from the truck lights to the snowplow lights. Activate high beam/low beam and turn signal/parking lamps from the truck as you normally would without the plow attached.

NOTE: When removing the plow, remember to place the headlight switch in the "truck" position to return power to the truck's headlights.

Raise or lower the plow by moving the joystick to the "raise" or "lower" position. Hold the plow at an intermediate height by releasing the controller from the "raise" position when the plow reaches the desired height. Moving the controller to the "lower" position will lower the blade to the ground and allow the plow to "float" along the contour of the ground while plowing snow. A yellow light on the control box indicates the plow is in the float mode. Momentarily moving the joystick to the "raise" position will remove the plow from the float condition and the yellow indicator will return to green.

Move the joystick left or right to angle the blade. Release the joystick when the blade is at the desired angle.

TRANSPORTING THE PLOW

The extra weight of the snowplow on your truck will impair handling response and increase braking distance. The plow will also block some airflow to the vehicle's cooling system, possibly causing the vehicle to overheat. Therefore, it is important not to exceed speeds above 45 mph when the plow is attached. Remove the plow if you must drive your truck for long distances when the temperature is warm.

Raise the blade to a position where it will not interfere with the headlights before driving. Transport the plow with power to the joystick control box switched off to prevent accidental lowering of the plow. Never adjust the blade height or angle the blade while driving.

PLOWING SNOW



WARNING: Always wear a seat belt when plowing snow. Sudden contact with a hidden object can result in serious personal injury.

Inspect areas to be plowed before snowfall for potential hazards, and mark obstructions with stakes that will be seen when snow covers the ground. Identify any emergency equipment and utility outlets that may need to be cleared in the event of a storm. Prepare a plan beforehand for clearing snow from tight or enclosed areas and locate sites for stacking snow.

Adjust the skids at the back of the moldboard according to the surface to be plowed. The bottom of the skids should be about 1/2" below the cutting edge when plowing gravel roads or lots. Skids should be even with the cutting edge on hard surfaces such as asphalt or concrete.

Always plow snow as it is accumulating. Wet snow may weigh about 12 pounds per cubic foot. The weight of snow being pushed by your plow may increase to several tons.

Allowing snow depth to grow to unmanageable levels can cause difficult removal problems and can be costly in terms of wear on equipment.



WARNING: Serious personal injury can result from plowing at excessive speeds, as well as costly damage to equipment and property, if an obstruction is encountered while plowing. Do not exceed 10 mph while plowing.

Plow snow in the lowest truck gear to transfer maximum power to the cutting edge. Clear areas in front of buildings first. Backdrag snow away from buildings by driving to the building with the plow raised, then dropping the blade to pull snow away. Push snow to outer edges of the lot after snow is away from building.

Clear large lots by angling the blade and creating a single path. Roll snow to outer edges of the lot by taking successive passes with the blade angled.

When plowing very deep snow, it may be necessary to raise the blade and shear off layers of snow until a working area is cleared. Work small areas in multiple passes to push snow to outer edges. Generally, 6 inch snow can be plowed with the entire blade width; 9 inch snow with 3/4 of the blade width; 12 inch snow the 1/2 of the blade width. Local conditions will determine how much work can be done before stalling or getting stuck.

REMOVING THE PLOW

Lower the plow to the ground when parking your truck for a long period of time with the plow attached. Place the on/off switch in the "off" position to prevent the plow from drawing power from the truck battery. The plow's power unit may continue to draw electrical current from the truck battery if the control switch is left on; possibly resulting in insufficient charge to start the truck.

To remove the snowplow from your truck, park the truck on a solid level surface with the blade straight or angled slightly to the right. Lower the plow to the ground and leave the controller in the "float" mode.

NOTE: The plow control box must be in the "float" mode to move the cylinder rod. If the cylinder rod does not retract with power on and the controller in float, loosen the packing nut on the lift cylinder up to 1 1/2 turns to reduce friction.

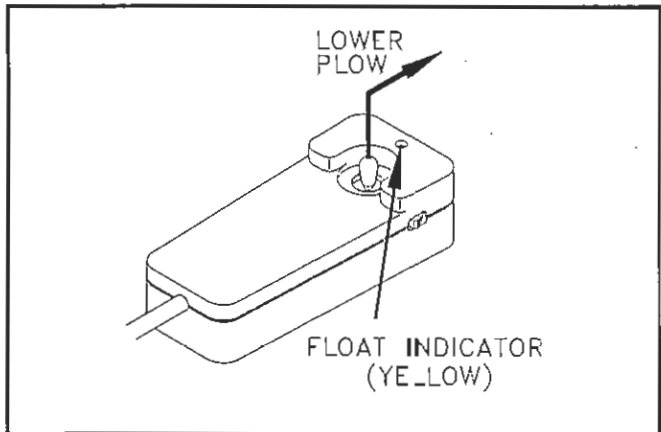

Lower Plow, Leave Controller In "Float" DWG. NO. 4177

At the front of the truck, push down on the upper lift links to fully retract the lift cylinder rod. Retracting the lift cylinder will orient the prong receivers correctly for reattaching the plow later. Failure to retract the lift cylinder rod will allow the lift frame to fall forward, possibly causing personal injury or damage to plow components.

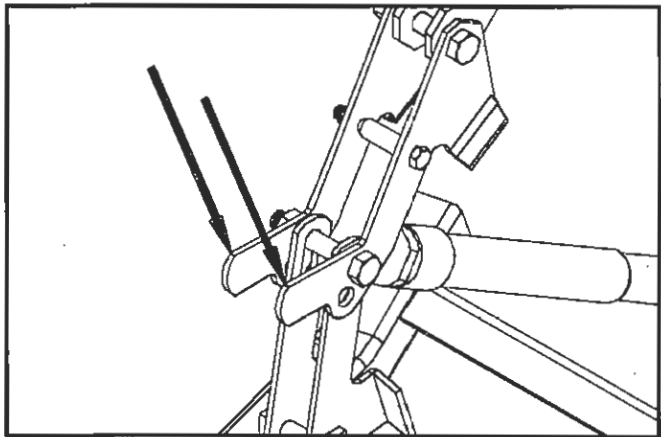

Retract Cylinder With Upper Lift Links DWG. NO. 4200

Swing the latch handle open until the latch sliders are fully removed from the attachment prongs.

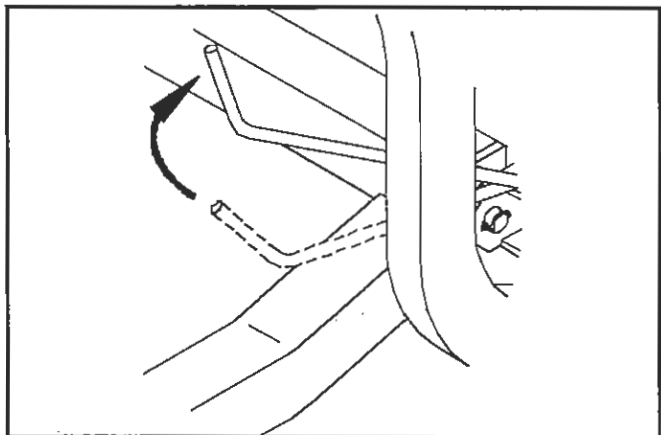

Swing Handle To Remove Sliders DWG. NO. 3856

Lower the parking stand to the ground by removing the tab lock pin from the stand index plate, then swinging the stand to the ground with the lever. Reinstall the pin in the index plate through the hole closest to the front of the lever to hold the stand in place.

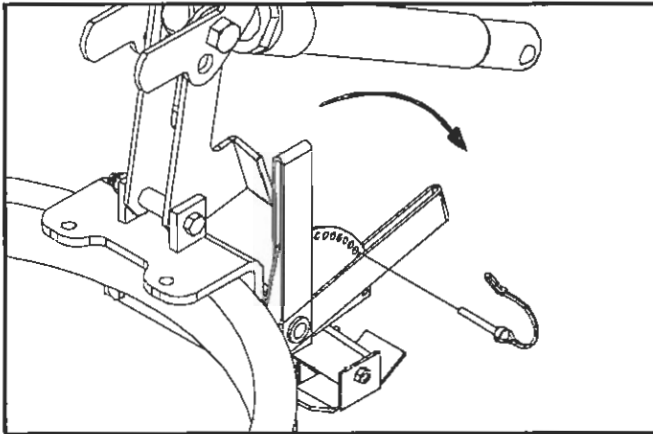

Lower and Pin Parking Stand

DWG. NO. 5251

Disconnect the two electrical connectors by pulling them straight out from the receptacles. Do not twist the connectors, twisting will damage the connector pins or the wiring harness.

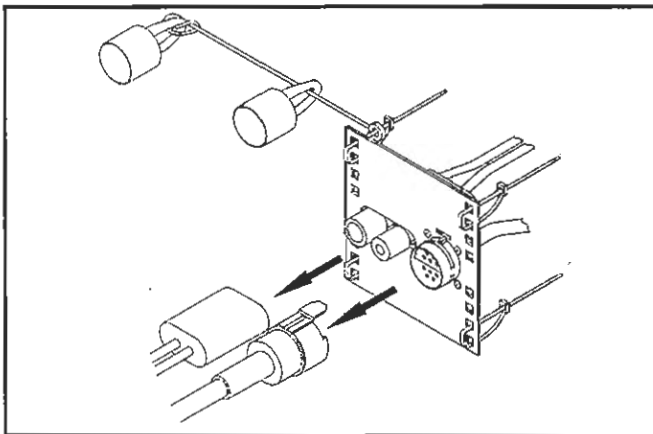

Disconnect Plugs

DWG. NO. 3925

Back inside the truck, return control of the headlights to the truck and switch power off on the snowplow control box, then slowly back the truck out from the plow.

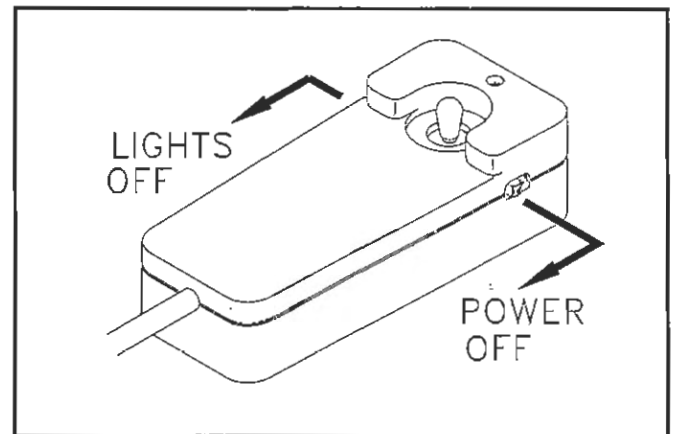

Turn Off Lights and Power

DWG. NO. 4178

If the snowplow won't be used for an extended period of time, the prong weldment can be removed from the truck by removing the hex bolts that fasten it to the truck mount frame.

TROUBLE SHOOTING

GENERAL

1. Check to see that the motor is wired correctly with tight connections, for the proper voltage.
2. Check reservoir oil level.
3. Check that wiring harness relay connections are wired correctly.
4. Check for external leakage at cylinders, hoses and power unit.

PROBLEM	POSSIBLE CAUSE	REMEDY
1. Plow does not attach to vehicle	A. Receivers are tipped forward B. Prongs recoil out of receivers when attaching C. Park stand pinned too low	A. Fully collapse lift cylinder with pedal before removing plow from truck B. Slowly drive into receivers and set parking brake C. Lower receivers by adjusting park stand
2. Pump motor does not run	A. Defective solenoid B. Defective pump motor C. Weak or defective battery D. Bad electrical connections E. Defective joystick control box F. Blown fuse supplying power to control box	A. Replace solenoid B. Replace pump motor C. Charge or replace battery D. Clean and tighten connections E. Replace control box F. Replace fuse
3. Pump runs with joystick in neutral	A. Defective solenoid B. Defective joystick control box C. Wiring short	A. Replace solenoid B. Replace control box C. Locate and repair
4. Plow will not lower	A. Reversed wiring on valve block B. Defective joystick control box C. Defective lift return valve or coil	A. Correct wiring B. Replace control box. C. Replace valve or coil
5. Plow will not raise or raises slowly, motor runs	A. Weak or defective truck battery B. Oil level low C. Flow control valve not installed correctly D. Hydraulic connection leak E. Lift valve not opening properly	A. Charge or replace battery B. Add oil (do not overfill) C. Arrow on flow control valve must point toward valve block D. Tighten or redo connection E. Replace valve
6. Plow does not remain raised with joystick in "neutral" position	A. Leakage through pump check valve B. Leakage through solenoid lowering valve C. Internal leakage in cylinder D. Defective joystick control box.	A. Clean valve, or replace B. Clean valve, or replace C. Repack or replace cylinder D. Replace control box

PROBLEM	POSSIBLE CAUSE	REMEDY
7. Angling cylinders relieve too easily or too difficultly while plowing	A. Relief pressure set too low or too high	A. Have relief pressure adjusted by Hiniker snowplow dealer
8. Oil leaks from cylinder(s)	A. Loose packing B. Defective cylinder	A. Tighten packing 1/8 turn B. Repack or replace cylinder
9. Battery goes dead with power to the control box on and joystick in neutral position.	A. Short in wiring B. Short in valve coil(s) C. Defective joystick control box	A. Locate and repair B. Replace coil(s) C. Replace control box
10. Battery goes dead with power to the control box off.	A. Short in wiring	B. Locate and repair
11. Plow lights are dim	A. Bad connection(s) B. Lights not properly grounded	A. Repair connection B. Properly ground
12. Plow does not clean-up snow from low areas	A. Joystick controller in neutral	A. Controller should be in the down position (float)
13. In extremely cold temperatures, the oil in the hydraulic system is thickened, causing slow functioning of the plow	A. Cold temperatures	A. As the system warms, the oil will thin out and function normally. B. Select a recommended oil from the chart on Page 10 for plowing in extremely cold temperatures.
14. Pump chatters when raising plow	A. Hydraulic oil low	A. Add hydraulic oil until chattering stops. Do not overfill.
15. Oil running out of cap on hydraulic reservoir	A. Plowing on steeply inclined terrain B. Too much oil	A. Avoid excessive inclines or change direction of plowing B. Remove excess oil
16. Vehicle overheats with the plow on	A. Vehicle coolant level low B. Ice and snow buildup in grill C. Insufficient airflow to engine compartment	A. Add coolant B. Remove ice and snow C. Transport plow at lower speeds
17. Plow lights do not operate with plow attached	A. Light switch on joystick control box in "truck" position B. Defective relay C. Faulty light switch on joystick control box D. Blown fuse on vehicle accessory feed	A. Move switch to "plow" position B. Replace relay C. Replace joystick control box D. Replace fuse
18. Truck headlights do not operate properly with plow removed	A. Light switch on joystick control box in "plow" position B. Defective relay	A. Move switch to "truck" position B. Replace relay

MAINTENANCE

Dependable snowplow operation is the result of following good maintenance procedures. Inspect your plow frequently to ensure that all parts are working smoothly, and develop a schedule for maintenance at required intervals.

GENERAL

Wash salt and dirt off the plow before storage. Touch-up any chips or scratches in the paint and apply a light coating of grease to extended cylinder rods to prevent corrosion.

HYDRAULIC SYSTEM

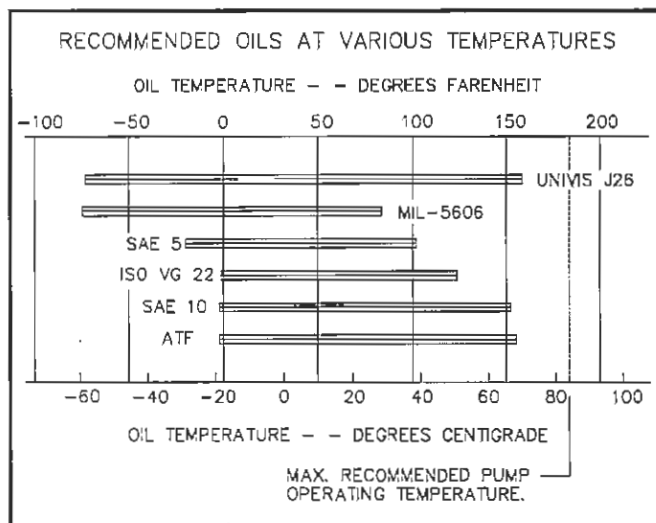

DWG. NO. 3066

The majority of snowplow operational problems are caused by bad oil in the hydraulic system. Hydraulic oil should be changed every year for best performance. Select a high quality oil that is appropriate for the temperatures in which you will be plowing snow.

To change hydraulic oil, disconnect the electrical wiring harnesses from the snowplow power unit and uncouple three hydraulic lines. Unbolt the power unit from the plow, and remove it to a clean working area that can capture any spilled oil.

Carefully unbolt the oil reservoir from the power unit and discard old oil. Purge old oil from the angling cylinders by forcing rods to retract.

Clean the suction filter at the pump inlet and wipe any metal shavings off the magnet on the pump.

Re-attach the reservoir onto the power unit and re-connect the power unit on the snowplow before adding new hydraulic oil.

Pour hydraulic oil into the power unit reservoir until the reservoir is half full. Angle the plow full left or right to fill the angling cylinder with oil, then add more oil until the reservoir is about 3/4 full. Do not overfill the oil reservoir.

Cycle the plow left and right and up and down to purge any air trapped in the hydraulic system.

MECHANICAL COMPONENTS

Prior to the operation of a new snowplow, or one which has been stored, inspect all hardware and verify proper torque on all bolts and nuts in accordance with the recommended torque specifications.

GRADE 5 TYPE B & F LOCKNUT TORQUES

Size	Ft-lbs.	N-m
5/16"	13-18	17-25
3/8"	23-33	31-44
1/2"	58-82	79-112
5/8"	117-165	158-223

GRADE 5 BOLTS TORQUES*

Size	Ft-lbs.	N-m
1/4"	8-12	11-16
3/8"	29-41	39-56
1/2"	73-103	99-140
5/8"	146-206	198-279

Loose bolts can cause hole elongation and part failure resulting in dangerous operating conditions and equipment breakdown.

Check all hardware periodically during operation and keep tightened to specified torques. Replace worn bolts and locknuts with grade 5 bolts and equivalent type B or type F locknuts. Type B locknuts are plain hex; type F locknuts are flanged hex.

The 5/16" hex bolts in the latch sliders are factory retained with anaerobic threadlock. If removal or replacement of these bolts is necessary, purchase new bolts with threadlocker from your Hiniker dealer, or apply a commercially available threadlock, i.e., Loctite 242 (blue) or Perma-Lok HM118 (red), to standard 5/16-18 x 3/4" grade 5 hex bolts before reassembly.

ELECTRICAL MAINTENANCE

Periodically check all electrical connections for proper fit and remove any contamination that may be present.

To prevent contamination always place dust caps on connectors when not in use. This is particularly important when the plow is being stored. The use of Dielectric grease is recommended.

Before each season check vehicle battery and electrical system for proper operation. A weak battery, dirty terminals, or faulty charging system may cause improper operation and possible failure of the joystick controller.

PLOW ASSEMBLY

GENERAL INFORMATION

WARNING: To prevent personal injury or death, be certain to keep clear of any parts that may drop when removing bundling straps, wires or brackets. Support heavy sections with hoist or blocks before removing wires or straps.

In the following instructions, left and right machine references are defined as being viewed from the cab of the truck. Be certain that hydraulic hoses and electrical wires are safely routed and allow full motion of moving parts. Secure loose wires with plastic tie straps. Some components are fastened at incorrect locations for shipping purposes.

All hardware should be tightened only enough to insure safety during assembly. Torque hardware to specified values, as shown in the following chart, only after assembly has been completed.

GRADE 5 TYPE B & F LOCKNUT TORQUES

Size	Ft-lbs	N-m
5/16"	13-18	17-25
3/8"	23-33	21-44
1/2"	58-82	79-112
5/8"	117-165	158-223

GRADE 5 BOLT TORQUES*

Size	Ft-lbs.	N-m
1/4"	8-12	11-16
3/8"	27-41	39-56
1/2"	73-103	99-140
5/8"	146-206	198-279

* applications without locknuts

Replace worn bolts and locknuts with grade 5 bolts and equivalent type B and type F locknuts.

Type B locknuts are plain hex; type F locknuts are flanged hex.

PLOW ASSEMBLY

Remove the upper and lower shipping brackets and save the four 5/16" x 1 1/4" hex bolts and 5/16" lock nuts for later assembly.

1. Place moldboard face down on cardboard or other padding that will prevent scratches in the paint. Remove the skid assemblies by cutting the black cable ties from the back of the moldboard.

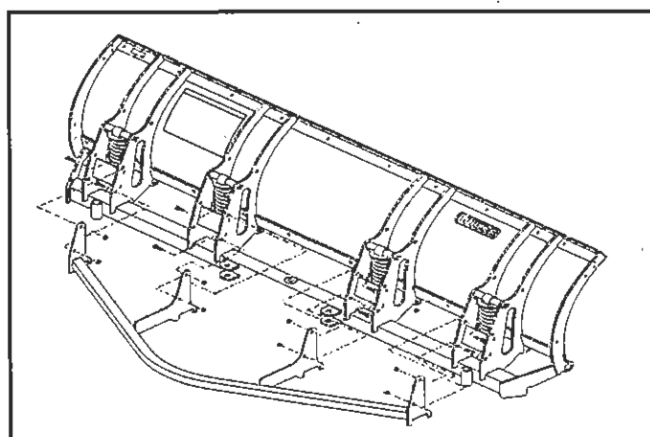
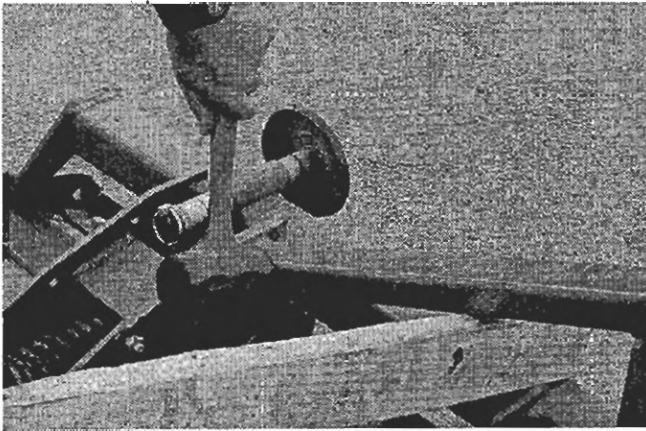

PHOTO NO. 5250

Wrap hoist straps or padded chains firmly around the frame weld. Remove the eight 1/2" x 1 1/4" bolts and 1/2" lock nuts from the inner ribs attaching the frame weld to the moldboard assembly. Attach the frame weld into its working position by lining up the slot on one end of the frame weld. Then, insert a 1/2" bolt into that end of the frame weld to hold it in place.

Next, pry the other end of the frame weld with a 2 x 4 until the slots on the frame weld line up with the 3 x 3 tube. Then pound into place with a rubber hammer. See Photo 5292.

Line up the holes on the side that was pounded in with a punch and insert another 1/2" bolt. Finally, insert the other 1/2" bolts and secure with 1/2" lock nuts.



DWG. NO. 5292

2. Open the frame crate and set aside the power unit box, head lamp boxes and parts box for later assembly. Carefully lift the frame assembly by wrapping straps or padded chains around both ends of the 2 1/2' square tube at the rear of the frame. Attach the frame assembly to the moldboard assembly by removing the 3/4" x 5" hex bolt and 3/4" lock nut from the hitch plate at the front of the push frame.

Remove the two 1/2" x 6" hex bolts, 1/2" lock nuts, and 2 13/16" push frame bushings from the push frame. Then, insert the 3/4 x 5" hex bolt through the bushings in the center of the 3 x 3 square tube on the moldboard assembly and through the hitch plate. Secure with the 3/4" lock nut. Insert the 1/2" x 6" hex bolt through the 2 13/16" push frame bushing and the 2 1/8" x 7/8" O.D. bushing on the push frame. Secure the 1/2 hex bolt with the 1/2" lock nut. Attach the angling cylinders to the moldboard assembly by inserting the 3/4" x 3" clevis pins through the lugs on the 3 x 3 square tube and securing them with cotter pins.

3. Tip the moldboard and frame assembly to their working positions with a hoist or fork truck. Pin the parking stand to hold the square tubes of the push frame parallel to the ground. Attach the skid assemblies by inserting them into the bushings on the 3 x 3 tube. Adjust the skid assemblies as needed to accommodate this working position.

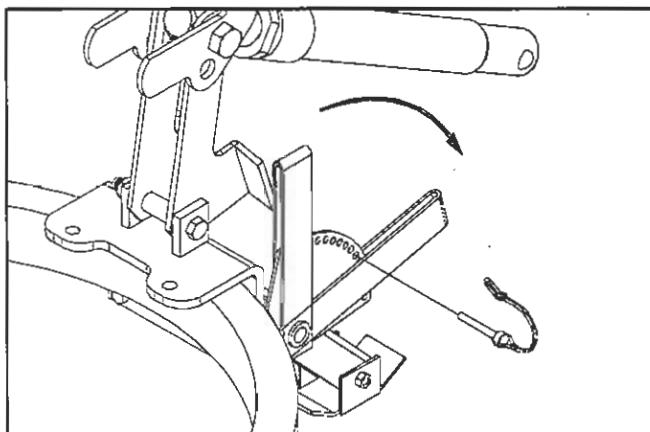

Lower and Pin Parking Stand

DWG. NO. 5251

Remove the 1/2" x 4" hex bolt and 1/2" lock nut holding the push frame and the frame weldment together. Save for installation later.

Swing the lift frame to its approximate working position and hold with a hoist or forklift for assembly of the lift mechanism. The bottom surface inside the two prong receiver channels should measure 10 inches above the ground in the working position.

4. Locate a 90° O-ring/flare adapter in the hardware bag and the lift cylinder from the parts box. Turn the O-ring end into the port of the lift cylinder so that the flare end is toward the rod end of the cylinder when tightened.

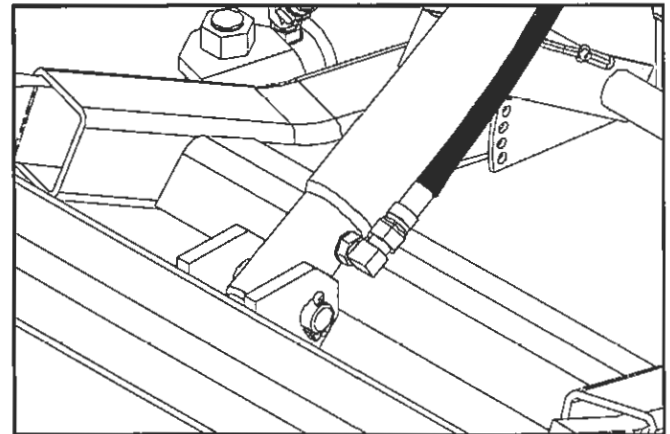

DWG. NO. 4202

Pin the base of the cylinder between the center lugs of the lift frame with the 3/4" x 3" clevis pin. The hydraulic fitting should be on the right side of the cylinder.

Remove the upper and lower lift links from the parts box. From the hardware bag find two 3/4" x 4 1/4" hex bolts, two 3/4" I.D. machine bushings, two 3/4 lock nuts, a 1/2" x 3 1/4" hex bolt, a 1/2" lock nut, and the upper and lower link spacers. Locate the 1/2" x 4" hex bolt and 1/2" lock nut removed from the frame assembly earlier.

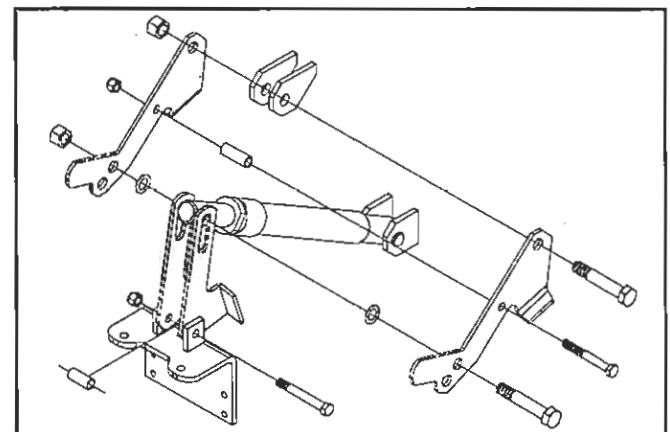

DWG. NO. 5259

Identify the RH and LH upper and lower links by referring to drawing 5259. Links should be assembled with stop surfaces away from the lift cylinder.

Assemble the stop end of the upper links on the outside of the frame weldment by inserting a 3/4" x 4 1/4" hex bolt. Attach the upper link spacer (the larger spacer) between these links with the 1/2" x 3 1/4" bolt through the next hole. Secure both hex bolts with appropriate sized lock nuts.

Install the lower links inside the tabs on the push frame, with the lower link spacer between the two links. Secure these links with the 1/2" x 4" hex bolt and a 1/2" lock nut.

Complete the lift assembly by bolting the cylinder rod, the lower links, and two machine bushings between the upper links with the other 3/4" x 4 1/4" hex bolt. Refer again to drawing 5259.

Pinning through the lower of the two bottom holes on the upper lift link will increase the downward plow travel for taller trucks, but reduce the lift height.

Remove the side markers from the top of the moldboard assembly. Attach them to the top two holes on the end ribs of the moldboard assembly using the 5/16" x 1 1/4" hex bolts and 5/16" lock nuts removed from the shipping brackets earlier.

5. Before assembling the power unit on the lift frame, scrape a small amount of paint from the two mount holes in the lift frame to provide a good electrical ground for the turn signals and parking lights.

Mount the power unit on the lift frame with two 3/8" x 3/4" hex bolts and two 3/8" lockwashers. The plastic reservoir of the power unit should be to the left side of the plow.

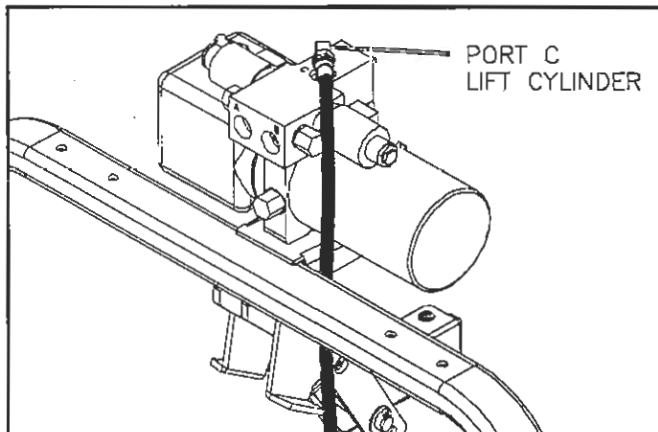

DWG. NO. 5082

Locate three 90° O-ring/flare adapters in the hardware bag. Turn the O-ring end of one adapter into the top port of the power unit so that it points about 45° to the right and to the rear when viewed from the top.

Turn the other two 90° adapters into ports A and B from the back of the power unit so that the flare ends point straight down.

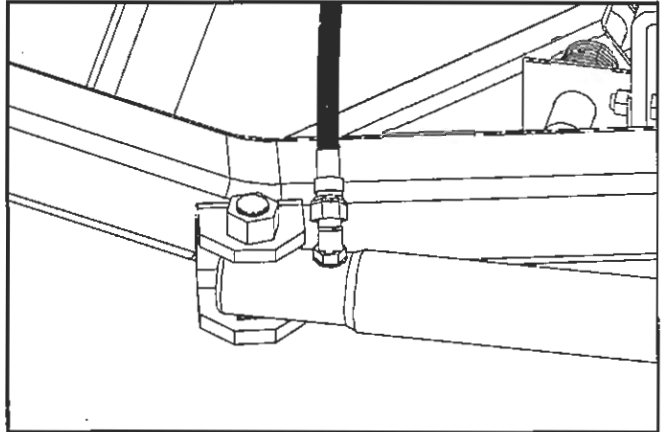

DWG. NO. 4205

Install 45° O-ring/flare adapters into the ports of the angling cylinders so that the flare ends are nearly parallel to the mount lugs of the push frame.

Three identical hydraulic hoses are in the parts box. Each hose has a swivel nut on each end that will assemble to the adapters from the power unit and three cylinders.

Connect one hose to the fitting from the top of the power unit, then route the hose ahead of the lift frame tube before assembling to the fitting from the lift cylinder.

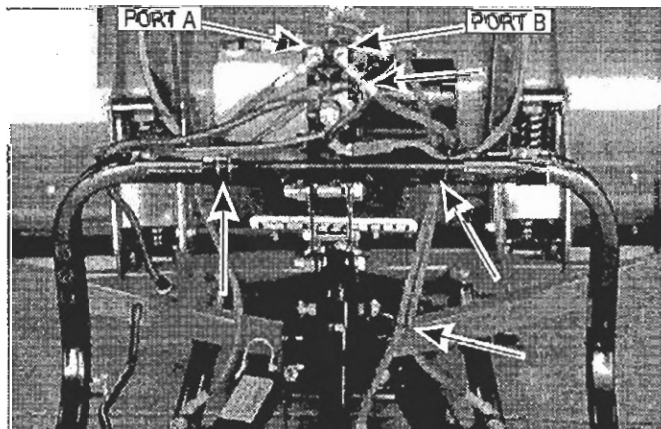

PHOTO NO. 5290

Connect the remaining two hoses to the fittings from ports A and B at the back of the power unit. Route both hoses ahead of the lift frame tube before assembling the hose from port A to the LH side angling cylinder and the

hose from port B to the RH side angling cylinder.

The fitting on the LH side angling cylinder may have to be adjusted slightly to route the hydraulic hose to best avoid interference with the latch handle and the lift links. Use plastic tie straps to secure all hydraulic hoses away from lift link stops.

- Before assembling the headlamp brackets on the lift frame tube, scrape a small amount of paint from the three holes in each bracket and from the four holes in the frame tube to provide a good electrical ground for the turn signals and parking lights.

Mount the headlamp brackets to the lift frame tube with four 3/8 inch x 2 inch carriage bolts and flanged lock nuts from the hardware bag in the parts box.

Remove the LH and RH headlamps from their boxes and mount on the brackets with hardware from the head lamp boxes.

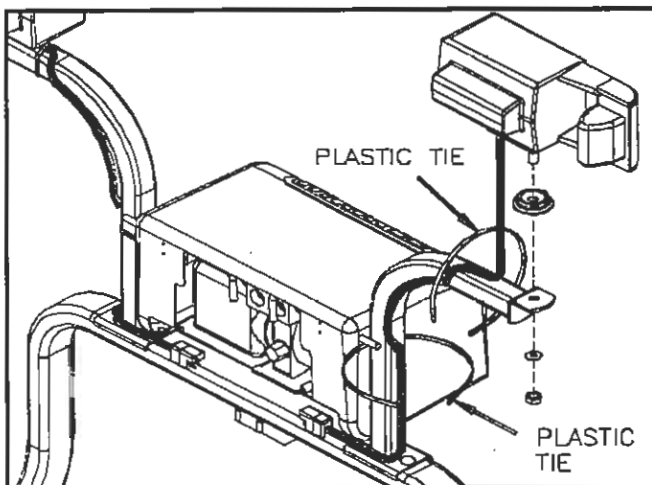

PHOTO NO. 5084

Use plastic tie straps to band headlamp cables above and below the brackets at the locations shown to provide clearance for the power unit cover later.

- Identify the plow power cable assembly and plow wiring harness in the parts box.

The power cable for the snowplow has two cables with ring terminals on one end and a two pin connector on the other and measures about 38" long.

The plow wiring harness has a ten-pin connector on one end and the other end has connectors labeled "DRIVER SIDE" and "PSNGR SIDE" for the headlamps and four loose wires with spade terminals.

Attach the ring terminal of the solid red (or red-striped) wire of the power cable assembly to the terminal on the power unit at location 1.

Fasten the ring terminal of the solid black wire of the power cable assembly and the ring terminal on the black wire of the plow harness under the screw on the motor at location 2.

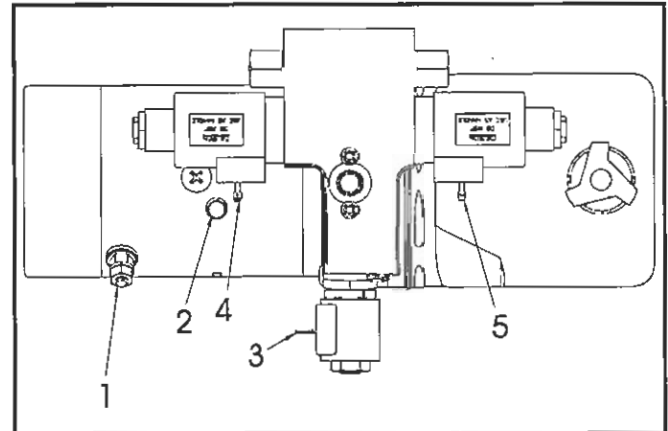

DWG. NO. 3939

Fasten the 1/4" spade receptical on the blue wire to the spade of the down solenoid at location 3.

Attach the gray wire to the spade terminal on the solenoid above the power unit's motor at location 4. This solenoid extends the right side of the plow to plow left.

Attach the tan wire to the spade terminal on the solenoid above the power unit's oil reservoir at location 5. This solenoid extends the left side of the plow to plow right.

Connect the RH headlamp to the wiring harness end labeled "PSNGR SIDE" and the LH headlamp to the end labeled "DRIVER SIDE". Secure these cables to the frame with plastic ties.

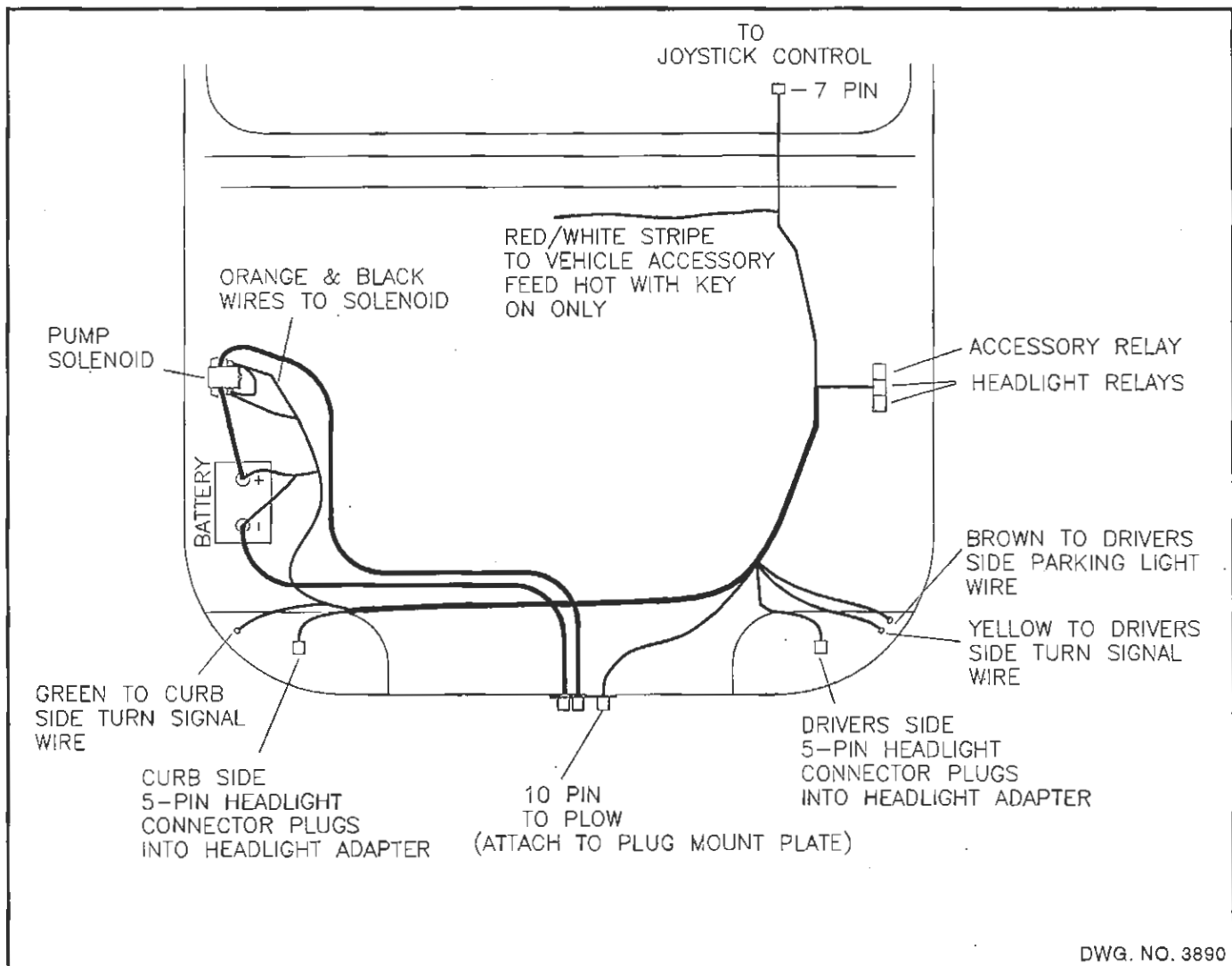

WARNING: Disconnect truck battery before beginning electrical installation to avoid shock hazard.

The pump solenoid, underhood wiring harness, power cable and joystick control box are located in the parts box shipped with the snowplow frame.

NOTE: Fill electrical connectors with dielectric grease, and lightly coat ring and spade terminals before installation to prevent corrosion.

8. Lay the harness in its approximate position for final assembly with the 7-pin circular connector near the drivers side firewall, the 10-pin connector just left of center near the grill, the relays near the drivers side inner fender and the 5-pin headlight connectors at the respective headlights.

9. Determine the location of the vehicle battery. If the battery is located on the right (passenger) side or if there are two batteries configured as a 12 volt system then proceed to step 10. If the battery is located on the left side of the vehicle then the wiring harness will need to be modified.

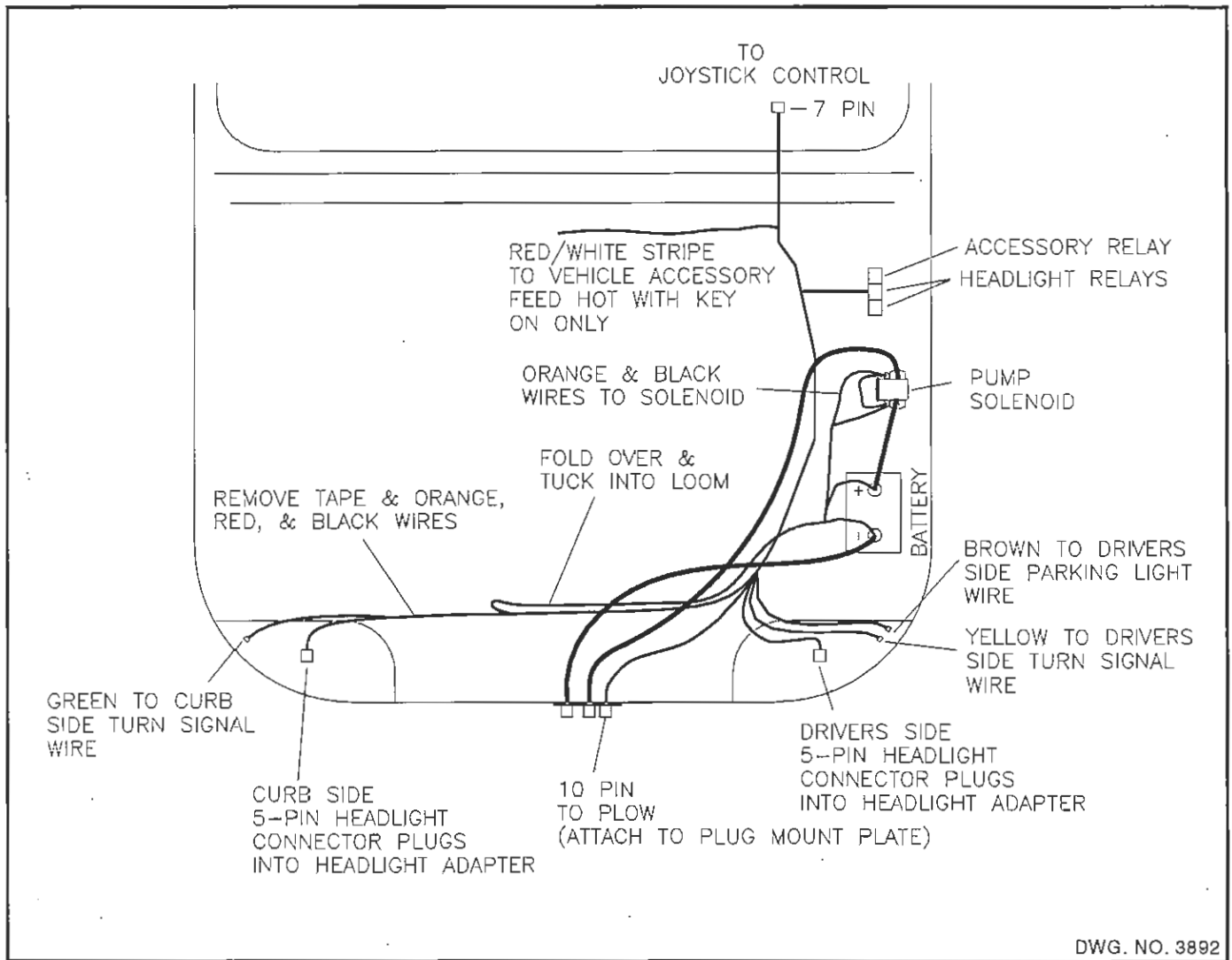

Refer to drawing (3892), remove the tape from the black corrugated loom at the points shown. Locate an Orange, Red, and two Black wires. These wires connect to the battery and pump solenoid located next to the battery. Remove the four wires from approximately 33 inches of the loom, making sure the Red and Black wires are long enough to connect to the battery. Tuck these wires back into the loom as shown in the drawing and retape the loom.

10. If there is no access hole in the drivers side firewall then drill a 1-1/8 inch diameter hole. Route the 7-pin circular connector through the firewall into the cab compartment and install the 4-inch grommet in the hole, if required.



CAUTION: Ensure that the relays will clear any hood lift/spring mechanisms before installation.

11. Select an area near the drivers side fender for the relays. Drill three 1/8 diameter holes and secure the relays with #8 x 1/2 inch self-tapping screws from the hardware bag in the parts box.
12. Splice the red with white stripe wire to the vehicle's switched 12 volt auxiliary electrical circuit. This will prevent operation of the plow without the vehicle key being on. This wire controls the accessory relay that powers the control joystick and solenoids.
13. Connect the joystick control box to the 7-pin connector inside the truck cab. Secure the box at a safe location in the cab with the strip of hook and loop fastener.

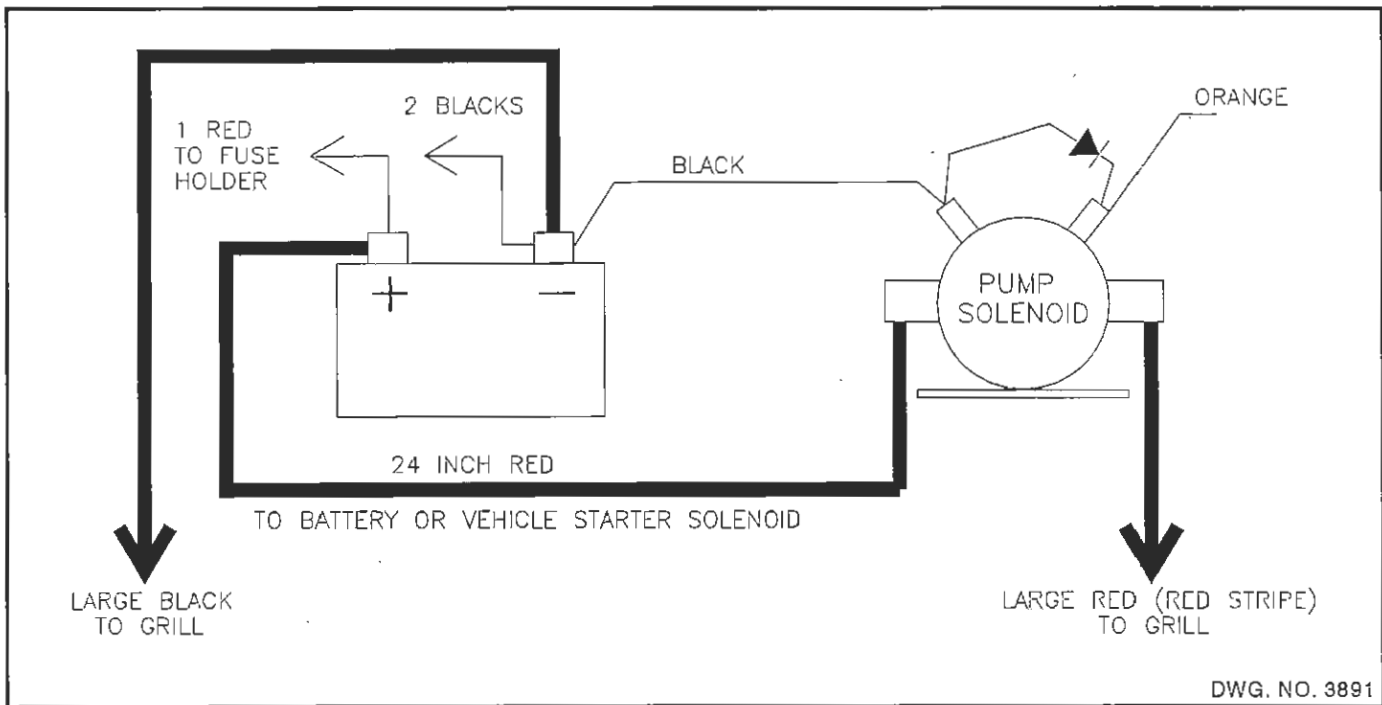

WARNING: Ensure that the pump solenoid and associated wiring will clear any hood lift/spring mechanisms before installation.

14. Select an area within 16 inches of the vehicle battery for the pump solenoid. Drill two 3/16 diameter holes and fasten the solenoid with two 1/4 inch x 1/2 long self tapping screws from the hardware bag in the parts box. Connect the Black wire to one of the small posts on the solenoid, connect the Orange wire to the remaining small post, polarity is not important.
15. Safely route the 10-pin circular connector through the grill of the vehicle to a location that will be easily accessible with the plow attached.
16. Refer to drawing 3891. Install the underhood power cable by first connecting the ring terminal from the solid Black cable and the 2 Black wires from the harness to the minus(-) post of the vehicle's battery. Connect the ring terminal from the solid Red (or Red striped) cable to the pump solenoid terminal, route the power cable to the grill near the 10-pin connector.

Install the 24 inch Red power cable between the pump solenoid and the vehicle's starter solenoid positive terminal. If the vehicle's starter solenoid is not accessible, connect the Red (or Red striped) cable to the plus (+) terminal of the battery. Connect the Red fused wire to the positive terminal of the battery.

17. Remove the plug mount plate, plastic clamp and mounting hardware from the hardware bag in the parts box.

Refer to drawing 3900.

Fasten the power cable connector to the clamp by inserting the #6 x 1 inch machine screw through the small hole in the connector, then through the center hole of the clamp. Secure the screw with a #6 lock nut.

Fasten the clamp to the mount plate with the two #10 x 1-1/2 inch machine screws and #10 lock nuts supplied.

Mount the 10-pin circular connector to the mount plate with four #6 x 1/2 inch screws and lock nuts such that the tab on the connector will be up, as shown.

Assemble the mount plate and connector covers to the vehicle grill with plastic ties.

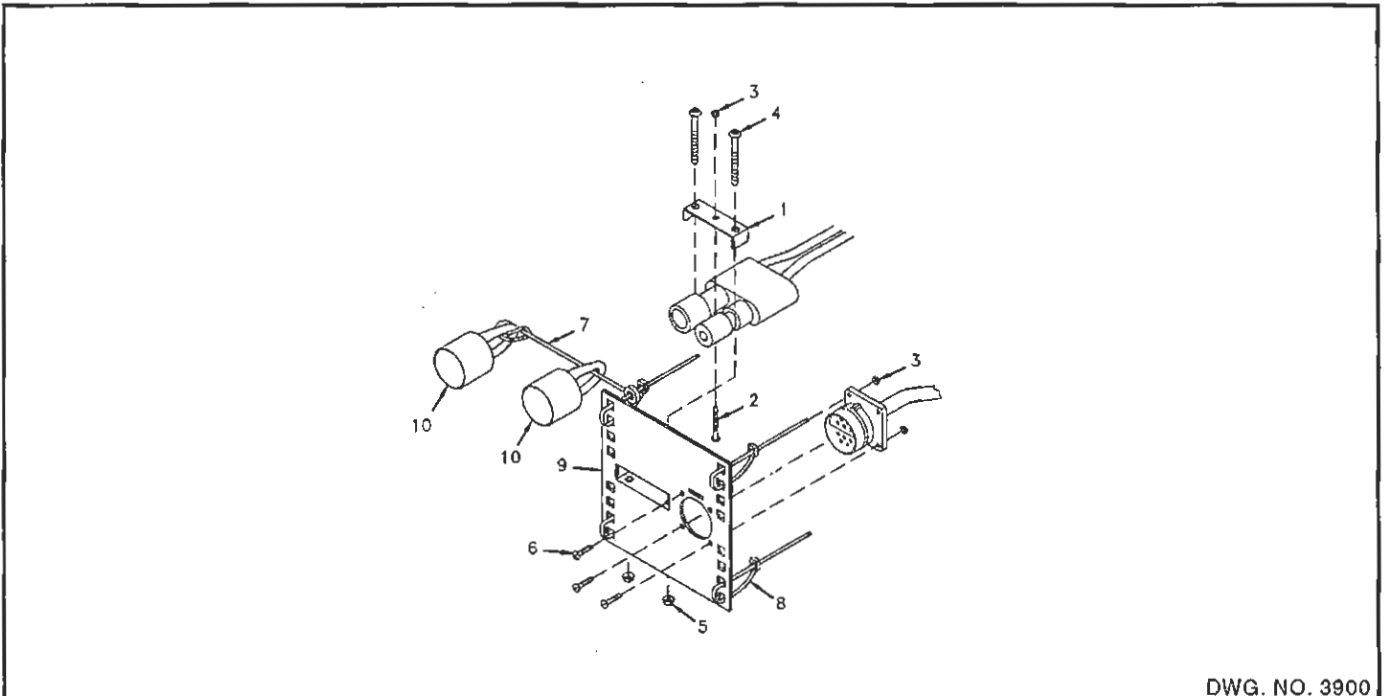

DWG. NO. 3900

REF. NO.	PART NO.	DESCRIPTION	QTY.	REF. NO.	PART NO.	DESCRIPTION	QTY.
1	25011037	Clamp	1	6	950-004-033	Machine Screw #6 - 32 x 1/2'	4
2	700-10904	Machine Screw #6 - 32 x 1"	1	7	36716025	Nylon Lanyard 8"	1
3	951-003-014	Locknut #6 - 32 Nylon Insert	5	8	367-001-011	Cable Tie 14"	4
4	950-004-076	Machine Screw #10 - 24 x 1 1/2"	2	9	25010278	Plug Mount Plate	1
5	392-010-010	Locknut #10 - 24 Nylon Insert	2	10	36716002	Dust Cap	2

18. Locate three blue connector splices in the hardware bag in the plow's parts box.

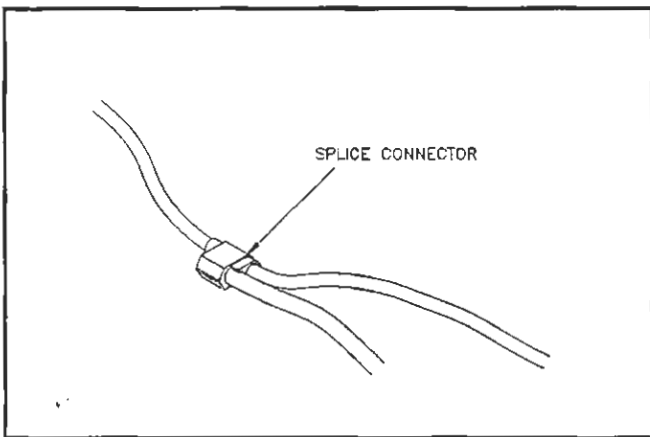

DWG. NO. 3088

Using a blue splice crimp the single brown wire from the underhood harness into the vehicle's driver's side parking light wire.

Using a blue splice crimp the single yellow wire from the underhood harness into the vehicle's driver's side turn signal wire.

Using a blue splice crimp the single green wire from the underhood harness into the vehicle's curbside turn signal wire.

19. Select the proper headlight adapter for your vehicle, specific instructions are included with each kit.

The headlight adapter kit consists of two identical adapters. Install the adapters according to the instructions included with the kit and connect to the 5-pin connectors of the underhood wiring harness.

20. Secure all cables away from hot or moving components with cable ties.

This completes the Electrical Installation.

21. At this point, the mount kit should be assembled onto the truck.

Prongs from the truck mount kit should be at a height that will slightly lift the plow frame when attaching the plow. Prong receivers on the plow frame should be parallel to the ground when attaching the plow. Apply powdered graphite on the truck prongs to help the plow to slide on and off more easily.

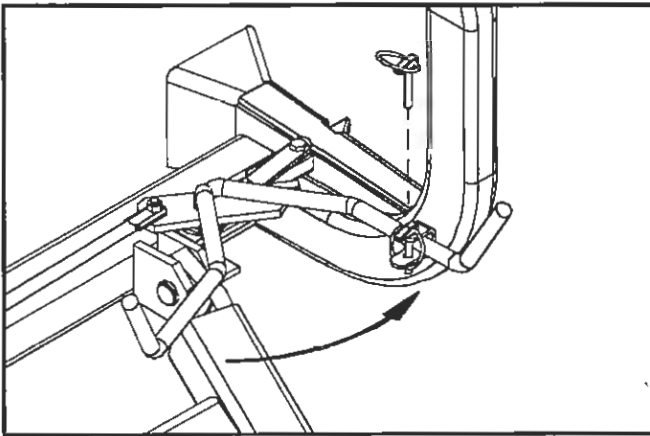

Handle Pinned With Plow on Truck

DWG. NO. 4199

Attach the plow onto the truck by driving the truck prongs into the receivers on the plow frame. Pull the latch handle into the frame clevis to move sliders through the notches in the prongs and receivers. Pin the handle in the clevis with its klik pin.

Raise the parking stand to its highest position and repin.

Connect the two electrical cables from the plow to their corresponding receptacles on the truck.

Select an appropriate hydraulic oil from the following chart.

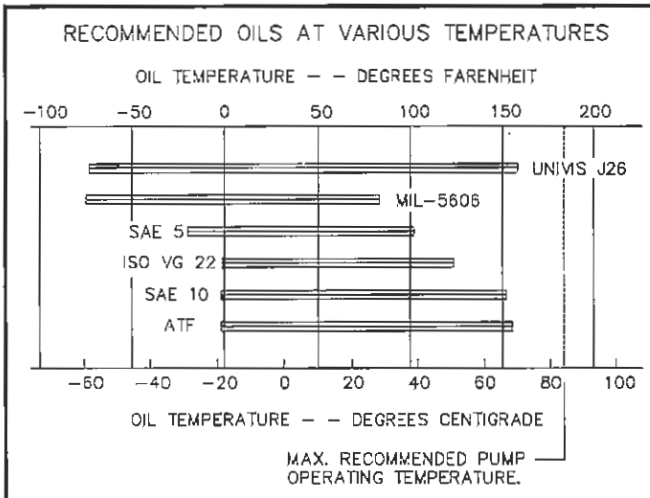

DWG. NO. 3066

Pour hydraulic oil into the power unit oil reservoir until the reservoir is half full.

Angle the plow full left or right with the cab control box inside the truck to fill the angling cylinder with oil. Add more oil until the reservoir is about 3/4 full. Do not over-fill the reservoir.

Cycle the plow left and right and up and down to purge any air trapped in the hydraulic system.

NOTE: New hydraulic cylinders will leak a small amount of oil until packings become saturated and produce a good seal. If leakage is excessive, or if leaking continues after initial cycling, tighten the cylinder packing nut in 1/8-turn increments until leaking stops.

- Fasten the power unit cover onto the lift frame bracket with two 1/4" x 3/4" carriage bolts, flat washers and locknuts from the hardware bag in the parts box. Tighten the locknuts so that the assembly is secure, yet the cover hinges freely.

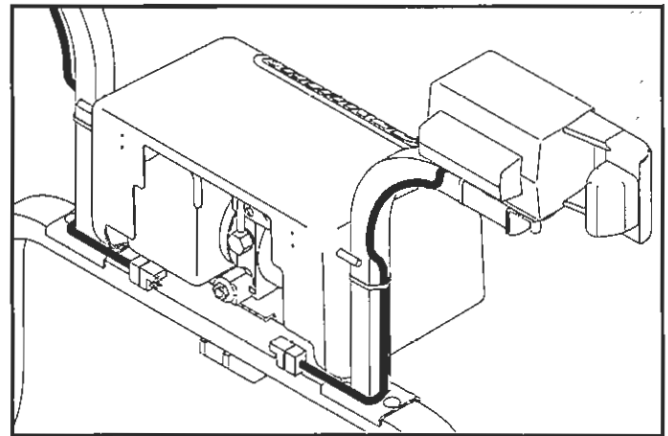

DWG. NO. 4198

Snip the plastic tie strap inside the cover assembly to release the two cover latch handles. When the cover is closed, rods from the latch handles should extend behind the light brackets to hold the cover in place.

- Assemble side markers on the ends of the moldboard with 5/16 inch bolts, flat washers and lock nuts.

SYSTEM CHECK-OUT

NOTE: The two-conductor high-current connectors between the plow and the truck must be connected to check out the plow and truck lights and the hydraulic motor/valve assembly.

1. Connect the 10-pin connector to the plow. Move the headlight switch on the joystick control box to the "TRUCK" position. Turn on the headlights. The truck lights should operate in both high and low beam.
2. Place the headlight switch on the joystick control box in the "PLOW" position. Turn on the headlights, the plow lights should now operate in both high and low beam positions and the truck headlights should be off.
3. With the 10-pin connector connected to the plow, test the parking lights and both turn signals. Both truck and plow parking and turn signals should operate at the same time. On the plow, the parking lights are a single light and the turn signals are dual lights.
4. With the 10-pin connector connected to the plow, test the operation of the joystick control box and hydraulics assembly. Assure that the plow assembly is free to move up/down and side to side and that all bystanders are clear.

If the blade angles opposite to that desired by the operator, exchange the tan and gray wires on the pump valve.

SPECIFICATIONS

Blade Width	8'	9'
Plow Width at 31°	7'3"	8'2"
Blade Height	30"	30"
Cutting Edge	3/8" x 6" 1084 steel	
Weight	853 lbs.	891 lbs.
Hydraulic Oil	1-1/2 qts.	
Sealed Beam	HP6545 12 VDC 4.00" x 6.50" (100mm x 165mm) rectangular hi/low (65w/45w)	
Turn Signal/Parking Bulb	One # 1157 heavy duty double contact 32/3 C.P. 12 VDC	
Starter Solenoid	12 VDC solenoid start switch	
Wiring Harness Fuse	10 AMP	

CAB CONTROL

UNDERHOOD HARNESS

EXTERNAL HARNESS

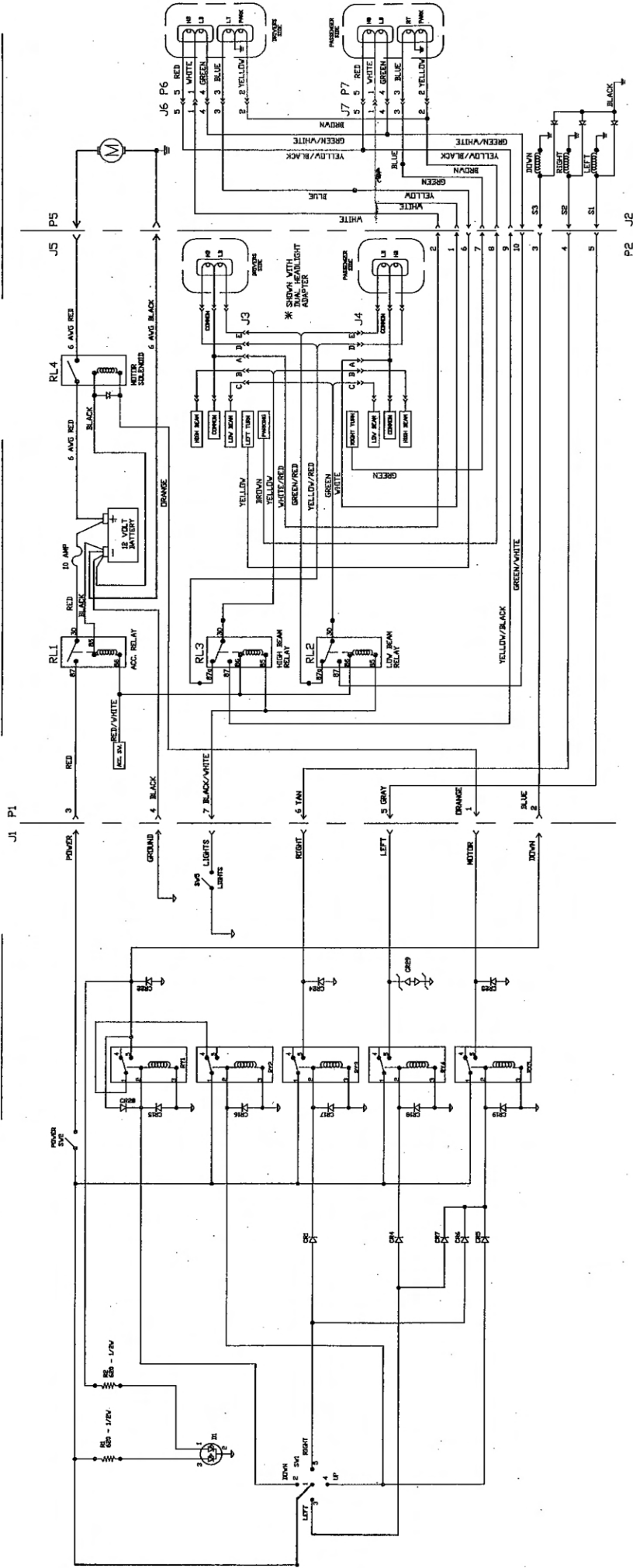

DWG. NO. 4217
DATE: 4-9-02
STANDARD PLOW 2001

STRAIGHT PLOW POWER UNIT

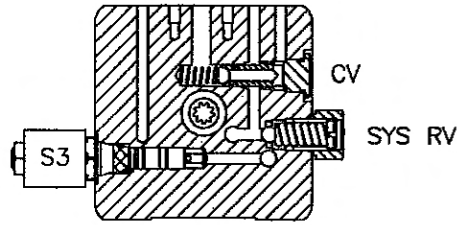
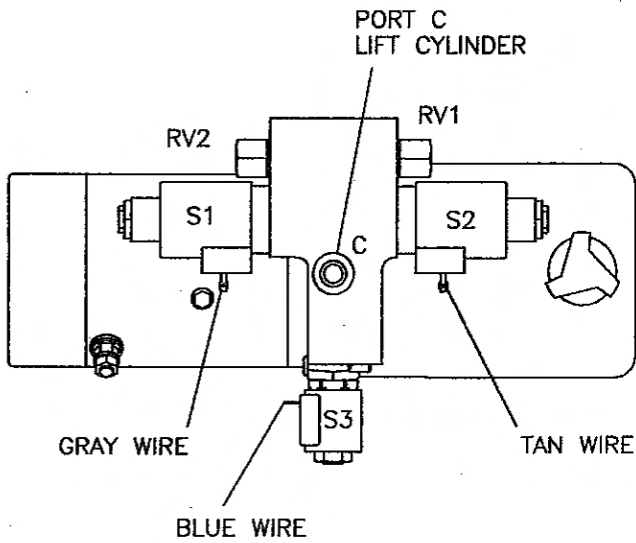

ENDHEAD SECTION

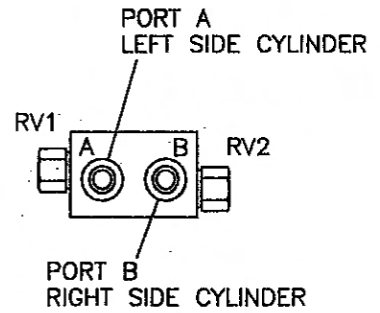
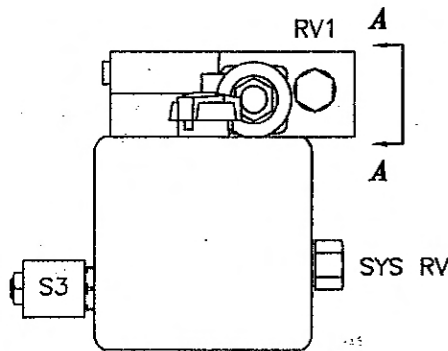
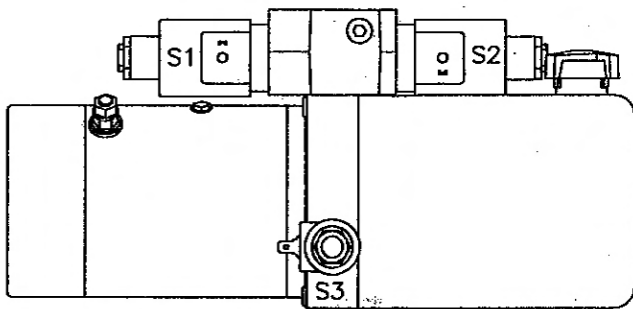

VIEW A-A

RV1 -- RELIEF VALVE, RIGHT SIDE CYLINDER, 2100 PSI
 RV2 -- RELIEF VALVE, LEFT SIDE CYLINDER, 2100 PSI
 SYSRV -- RELIEF VALVE, SYSTEM, 2000 PSI

POWER UNIT HYDRAULIC CIRCUIT DIAGRAM

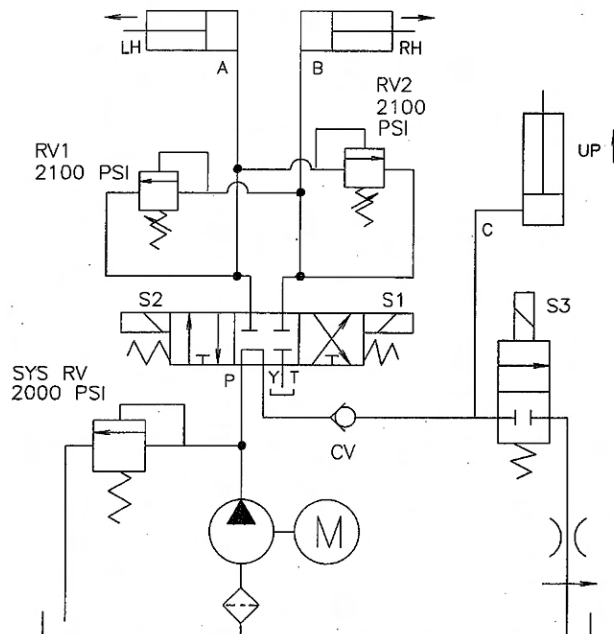

S1 - RIGHT EXTEND - GRAY WIRE
 S2 - LEFT EXTEND - TAN WIRE
 S3 - DOWN - BLUE WIRE

DWG. NO. 4180
 DATE: 4-11-02

HINIKER WARRANTY

The only warranty Hiniker Company (Hiniker) gives and the only warranty the dealer is authorized to give is as follows:

We warranty products sold by Hiniker or authorized Hiniker dealers to be in accordance with our published specifications or those specifications agreed to by us in writing at time of sale. Our obligation and liability under this warranty is expressly limited to repairing or replacing, at our option, within one year after date of retail delivery, to the original purchaser, any product not meeting the specification. **WE MAKE NO OTHER WARRANTY, EXPRESS OR IMPLIED AND MAKE NO WARRANTY OF MERCHANTABILITY OR OF FITNESS FOR ANY PARTICULAR PURPOSE.** Our obligation under this warranty shall not include any transportation charges or costs or any liability for direct, indirect or consequential damage or delay. If requested by Hiniker Company, products or parts for which a warranty claim is made are to be returned freight prepaid to our factory. Any improper use, operation beyond rated capacity, substitution of parts not approved by Hiniker Company, or any alteration or repair by others in such manner as in our judgment affects the product materially and adversely shall void this warranty. **NO EMPLOYEE OR REPRESENTATIVE IS AUTHORIZED TO CHANGE THIS WARRANTY IN ANY WAY OR GRANT ANY OTHER WARRANTY.**

HINIKER reserves the right to make improvement changes on any of our products without notice.

HINIKER does not warrant the following:

1. Used products.
2. Any product that has been repaired, modified or altered in a way not approved by Hiniker Company.
3. Depreciation or damaged caused by normal wear, lack of reasonable and proper maintenance, failure to follow Operator Manual Instructions, misuse, lack of proper protection during storage, or accident.
4. Parts replacement and service necessitated by normal wear or maintenance including, but not limited to, any ground engaging components.

A DELIVERY REPORT FORM must be filled out and received by HINIKER COMPANY to initiate the warranty coverage.

HINIKER COMPANY
58766 240th St.
P. O. BOX 3407
MANKATO, MN 56002-3407
PHONE (507) 625-6621
FAX (507) 625-5883
www.hiniker.com