



**PICKUP TRUCK SNOWPLOW  
V-PLOW**

**Models 1851, 1951**

**OPERATOR'S MANUAL**

DO NOT USE OR OPERATE THIS EQUIPMENT UNTIL THIS MANUAL  
HAS BEEN READ AND THOROUGHLY UNDERSTOOD

PART NUMBER 25010874 REV C

---

---

---



# TABLE OF CONTENTS

25010874 Rev. C

5/05

Hiniker/25010874RevC

---

TO THE PURCHASER.....	2
SAFETY.....	3
OPERATING PROCEDURES .....	4
TROUBLE SHOOTING .....	8
MAINTENANCE .....	10
ASSEMBLY .....	12
SYSTEM CHECK-OUT AND JOYSTICK CONFIGURATION .....	22
SPECIFICATIONS.....	23
WARRANTY .....	28

## TO THE PURCHASER

This product is designed and manufactured to give years of dependable service when properly maintained and used for the purpose for which it is intended. Never allow anyone to operate this equipment until they fully understand the complete contents of this manual. It is the responsibility of owners who do not operate this equipment to ensure the operator is properly instructed and understands the contents of this manual. It is also the owner's responsibility to ensure that anyone operating this equipment is mentally and physically capable of so doing.

Important information is contained in this manual to help ensure safe and efficient operation.

If you have any questions about this manual, or the equipment discussed herein, contact your Hiniker dealer.



**This is a safety alert symbol. It alerts an operator to information concerning personal safety. Always observe and heed these instructions, otherwise death or serious injury can result.**

All references to Left or Right are defined as viewing the plow from the cab of the truck.

Instructions for raising and lowering the plow refer to the joystick controller as received from the factory. The raise and lower functions may be reversed to suit the preference of the operator by following the instructions on page 22 for switching the controller joystick and face plate.

This Operator's manual is shipped with this equipment. Contact your Hiniker dealer for additional copies.

Always obtain original Hiniker service parts. Substitute parts could adversely affect equipment performance and warranty.

Check that your dealer has forwarded the Hiniker delivery report form along with the plow identification number because it helps maintain maximum service and warranty benefits. This does

not put you on any mailing list, and information thereon is not available to others.

Your plow's identification number decal is at location (1) in the following illustration.

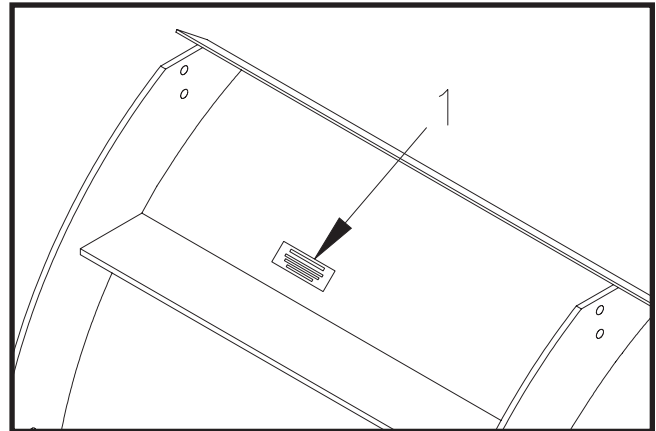

DWG NO. 3712

Record the following information for later reference when obtaining service parts:

Purchase Date \_\_\_\_\_

Purchaser's Name \_\_\_\_\_

Dealer's Name \_\_\_\_\_

Machine I.D. No. \_\_\_\_\_

# SAFETY

---



**This is a safety alert symbol. It alerts an operator to information concerning personal safety. Always observe and heed these symbols and instructions, otherwise death or serious injury can result.**

Operator safety is a principle concern in equipment design and distribution. However, many accidents occur because a few seconds of thought, and a more careful approach to handling, were ignored. Accidents can be avoided by knowing and following the precautions cited in this manual.

## GENERAL SAFETY

1. Read this manual thoroughly. Make sure the operator understands it and knows how to operate this equipment safely. This equipment can kill or injure an untrained or careless operator and bystanders. If you sell this equipment, ensure the new owner acknowledges receipt of this manual.
2. This plow is intended for plowing snow only. Plowing gravel, rocks, etc., or using the plow for any purpose other than plowing snow could result in harm to the operator or bystanders or cause damage to the plow or vehicle, and will void the warranty.
3. Do not service or otherwise handle a plow in the raised position unless it is securely blocked against unexpected falling. Likewise, when servicing a plow with the wings extended, block wings or disassemble wing return springs to prevent unexpected wing retraction due to accidental loss of hydraulic pressure or cylinder removal.
4. Do not attempt to handle or service this equipment, or direct others to do the same, unless you know how to do it safely and have the proper tools for the job.
5. Keep hands, feet, hair, and clothing away from moving parts.
6. Do not alter the equipment to the extent of compromising safety or performance.

## BEFORE OPERATION

1. Discipline yourself to visually check for worn, damaged or cracked parts before starting use. Replace these with genuine Hiniker parts.
2. Escaping hydraulic oil under pressure can penetrate the skin, causing serious injury.

Do not use your hand to check for leaks. Use a piece of paper or cardboard to find suspected leaks.

Tighten all connections before pressurizing hydraulic lines.

If fluid is injected into the skin, get medical attention immediately to prevent serious infection.

3. Check all controls and operating functions of the machine in a safe area before starting to work.

## DURING OPERATION

1. Always wear seat belts when operating a motor vehicle.
2. Ensure everyone is clear of the machine, especially away from blind areas of the operator, before starting, actuating hydraulics or operating this equipment.
3. Do not plow snow at excessively high speeds.
4. Avoid hitting objects that will damage your plow or truck.
5. Set the brakes and stop the truck's engine before adjusting or servicing your plow.

## AFTER OPERATION

1. Park the plow on a solid, level surface. Fully collapse the lift cylinder with the upper lift links before unhitching the plow to prevent the plow frame from falling forward.

## OPERATING PROCEDURES

### ATTACHING THE PLOW

Attachment prongs on the truck should be mounted such that the bottom edge of the prongs measure about 10 inches above the ground. Prong receivers on the plow frame should remain parallel to the ground and at the correct height by fully retracting the lift cylinder with the upper lift links before removing the plow from the truck (see “Removing the Plow”) Ideally, the prongs on the truck should lift the plow frame slightly when driving into the plow for attachment.

Powdered graphite applied on the prongs will help the plow slide on and off more easily.

Check that prongs are in line with the receivers before slowly driving into the plow. Set the parking brake in the truck to prevent it from creeping back out from the receivers.

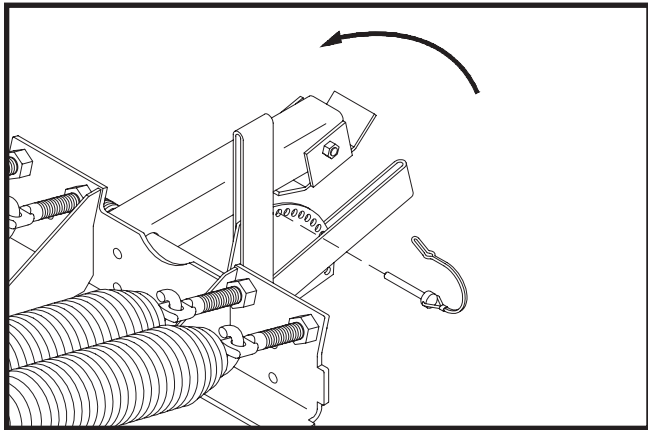

DWG NO. 5293

Remove the tab lock pin from the parking stand index plate to raise the stand to its highest position. Reinstall the pin in the plate for transport.

Pull the latch handle into the clevis on the lift frame to force the sliders through the notches in the prongs and receivers. Pin the handle in the clevis with its klik pin. Failure to pin the handle in place may allow the plow to fall off the truck.

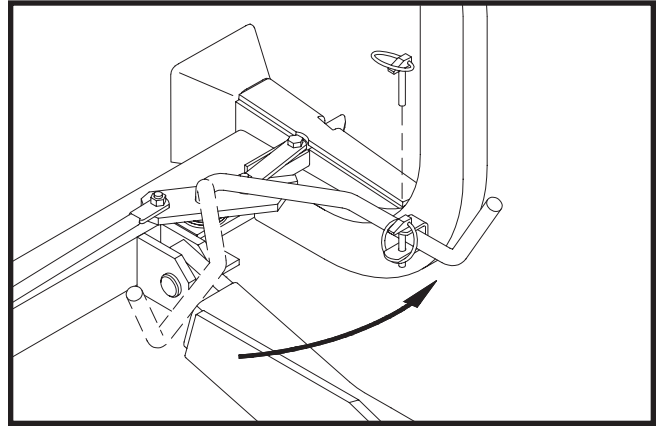

Handle Pinned With Plow On Truck

DWG NO. 4166

Plug in the three electrical connectors between the plow and the truck after latching the plow. The alignment tab on the 10-pin receptacle will mate with the slot in the mounting plate on the truck grill to ensure proper connection.

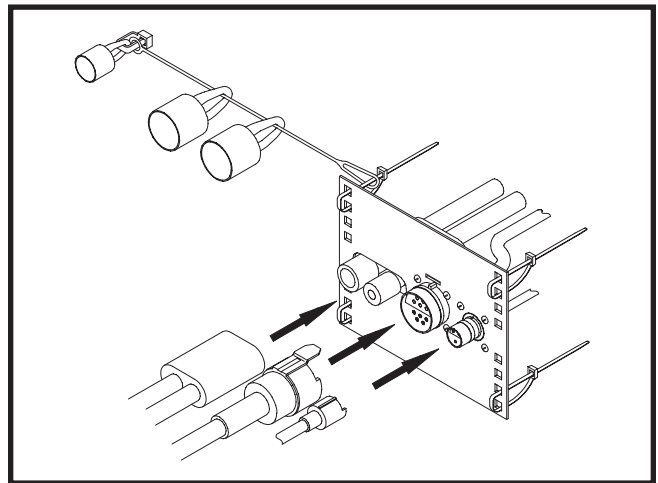

Alignment Tab and Slot

DWG NO. 5232

Check that the plow headlamps and turn signals are operational, and headlamps are aimed correctly. Test the lift and angling cylinders in a safe area before using the plow.

To make alignment of the plow easier in the future, mark a point on the back of the LH headlamp, a point on the hood near the front of the truck and a point on the windshield that are in

line when you are seated behind the steering wheel. Line up these three points when driving into the plow.

### THE JOYSTICK CONTROLLER

The joystick control box has slide switches for controlling power to the snowplow and for switching from the truck headlights to the headlights on the plow. The joystick controller raises and lowers the plow and angles the blade left or right. Two push buttons on the box are used to extend both wings to the scoop position or retract both wings to the V-position.

**NOTE:** Drawings 4181 and 4163 show the raise and lower functions of the joystick controller as received from the factory. Functions may be reversed to suit the preference of the operator by following the instructions on page 22 for switching the controller joystick and face plate.

The vehicle's electrical power must be turned on before the control box will function.

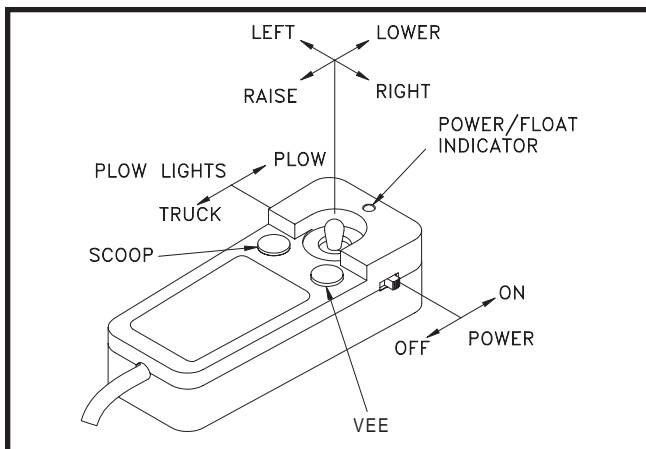

Joystick Control Box

DWG NO. 4181

Place the on/off switch on the joystick control box in the "On" position to supply power to the snowplow. A green light will indicate power is on.

Move the headlight slide switch on the control box to the "Plow" position to change from the truck lights to the snowplow lights. Activate high beam/low beam and turn signal/parking lamps from the truck as you normally would without the plow attached.

**NOTE:** When removing the plow, remember to place the headlight switch in the "Truck" position to return power to the truck's headlights.

Raise and lower the plow by moving the joystick forward and backward. Hold the plow at an intermediate height by releasing the joystick from the "Raise" position when the plow reaches the desired height. Moving the joystick to the "Lower" position will lower the blade to the ground and allow the plow to "Float" along the contour of the ground while plowing snow. The green light on the control box will turn yellow to indicate the plow is in the float mode. Momentarily moving the joystick to the "Raise" position will remove the plow from the float mode and the yellow light will return to green.

Raise the blade before working the wing functions of the plow to avoid resistance from the ground. Move the joystick left or right to angle the blade to that side. Push the left button on the control box to extend both wings into the scoop position. Push the right button to retract both wings into the V-position.

To hold the wings in position straight across the truck, start with the plow in the V-position, then push the left button on the control box to move both wings forward together and release the button when the wings are at the desired position.

### TRANSPORTING THE PLOW

The extra weight of the snowplow on your truck will impair handling response and increase braking distance. The plow will also block some airflow to the vehicle's cooling system, possibly causing the vehicle to overheat. Therefore, it is important not to exceed speeds above 45 mph when the plow is attached. Remove the plow if you must drive your truck for long distances when the temperature is warm.

Fully raise the plow, then move the wings into the V-position before driving. Transport the plow with power to the joystick control box switched off to prevent accidental lowering of the plow. Never adjust the blade height or angle the wings while transporting the plow.

## PLOWING SNOW



**WARNING: Always wear a seat belt when plowing snow. Sudden contact with a hidden object can result in serious personal injury.**

Inspect areas to be plowed before snowfall for potential hazards, and mark obstructions with stakes that will be seen when snow covers the ground. Identify any emergency equipment and utility outlets that may need to be cleared in the event of a storm. Prepare a plan beforehand for clearing snow from tight or enclosed areas and locate sites for stacking snow.

Level the plow in the scoop position by first loosening the jam nut on the stop bolt at the back of the center mast with a 1-1/2 inch open-end wrench, then turning the bolt in or out to adjust the plow ends. Retighten the jam nut once the plow is level with the ground.

Adjust the skids at the back of the moldboard according to the surface to be plowed. The bottom of the skids should be about 1/2" below the cutting edge when plowing gravel roads or lots. Skids should be even with the cutting edge on hard surfaces such as asphalt or concrete.

Always plow snow as it is accumulating. Wet snow may weigh about 12 pounds per cubic foot. The weight of snow being pushed by your plow may increase to several tons.

Allowing snow depth to grow to unmanageable levels can cause difficult removal problems and can be costly in terms of wear on equipment.



**WARNING: Serious personal injury can result from plowing at excessive speeds, as well as costly damage to equipment and property, if an obstruction is encountered while plowing. Do not exceed 10 mph while plowing.**

Plow snow in the lowest truck gear to transfer maximum power to the cutting edge. Clear areas in front of buildings first. Backdrag snow away from buildings by driving to the building with the plow raised, then dropping the blade to pull snow away. Push snow to outer edges of the lot after snow is away from buildings.

Begin clearing large lots by putting the plow in the V-position and creating a single path. Roll snow to the outer edges of the lot by taking successive passes with the blade angled, or put the plow in the scoop position and push snow to the end of the lot. Break up hard snowbanks with the plow in the V-position.

When plowing very deep snow, it may be necessary to raise the blade and shear off layers of snow until a working area is cleared. Work small areas in multiple passes to push snow to outer edges. Generally, 6 inch snow can be plowed with the entire blade width; 9 inch snow with 3/4 of the blade width; 12 inch snow with 1/2 of the blade width. Local conditions will determine how much work can be done before stalling or getting stuck.

## REMOVING THE PLOW

When parking your truck for a long period of time with the plow attached, move the wings into the V-position to reduce tension on the return springs, then lower the blade to the ground. Place the power switch in the "Off" position.

To remove the snowplow from your truck, park the plow on a solid level surface and move the wings into the V-position to reduce tension on the return springs. Lower the plow to the ground and leave the controller in the "Float" mode.

NOTE: The plow control box must be in the "float" mode to manually retract the lift cylinder rod. If the cylinder rod cannot be retracted with power on and the controller in float, loosen the packing nut on the lift cylinder up to 1 1/2 turns to reduce friction.

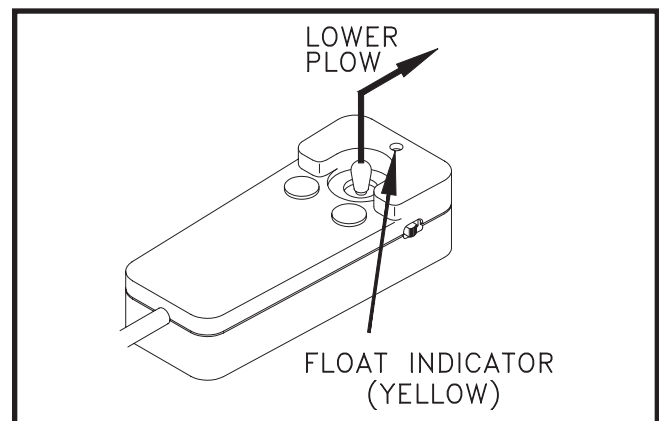

Lower Plow, Leave Controller In "Float" DWG NO. 4163

At the front of the truck, push down on the upper lift links to fully retract the lift cylinder rod. Retracting the lift cylinder will orient the prong receivers correctly for reattaching the plow later. Failure to retract the lift cylinder rod will allow the lift frame to fall forward, possibly causing personal injury or damage to plow components.



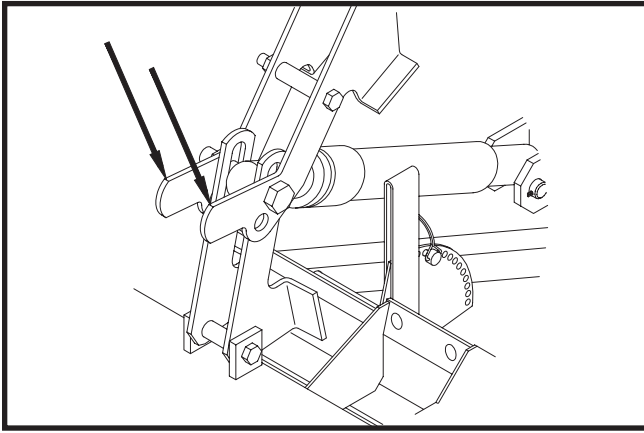

Retract Cylinder With Upper Lift Links DWG NO. 4167

Swing the latch handle open until the latch sliders are fully removed from the attachment prongs.

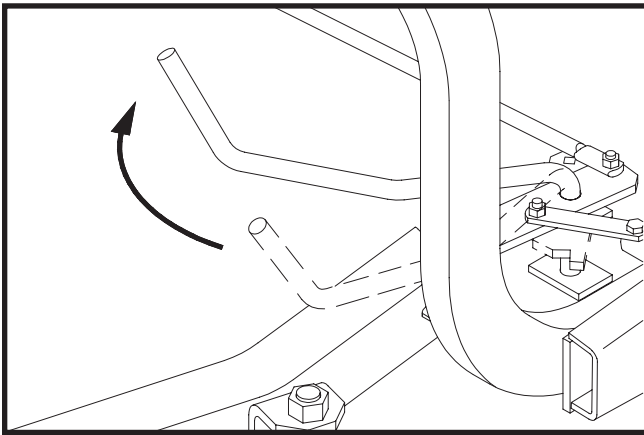

Swing Handle To Remove Sliders DWG NO. 3856

Lower the parking stand to the ground by removing the tab lock pin from the stand index plate, then swinging the stand to the ground with the lever. Reinstall the pin in the index plate through the hole closest to the front of the lever to hold the stand in place.

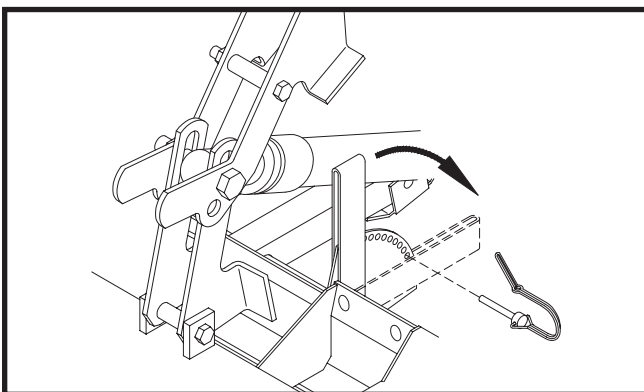

Lower and Pin Parking Stand DWG NO. 4168

Disconnect the three electrical connectors by pulling them straight out from the receptacles. Do not twist the connectors, twisting will damage the connector pins or the wiring harness.

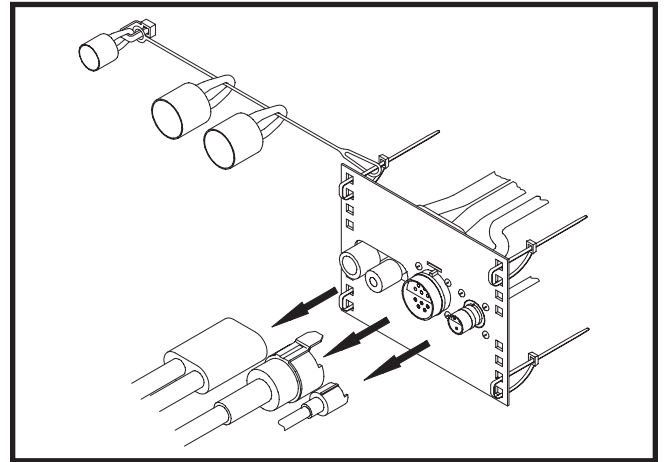

Disconnect Plugs DWG NO. 5233

Back inside the truck, return control of the headlights to the truck and switch power off on the joystick control box, then slowly back the truck out from the plow.

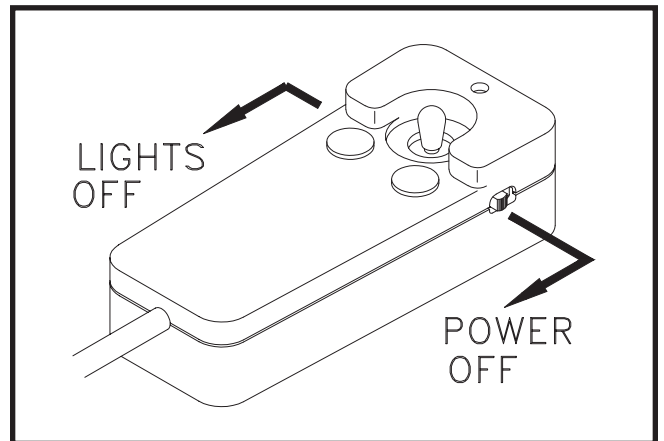

Turn Off Lights and Power DWG NO. 4164

If the snowplow won't be used for an extended period of time, the prong weldment can be removed from the truck by removing the hex bolts that fasten it to the truck mount frame.

## TROUBLE SHOOTING

### GENERAL

1. Check to see that the motor is wired correctly with tight connections, for the proper voltage.
2. Check reservoir oil level.
3. Check that wiring harness relay connections are wired correctly
4. Check for external leakage at cylinders, hoses and power unit.

PROBLEM	POSSIBLE CAUSE	REMEDY
1. Plow does not attach to vehicle	A. Receivers are tipped forward B. Prongs recoil out of receivers when attaching C. Park stand pinned too low	A. Fully collapse lift cylinder with upper lift links before removing plow from truck B. Slowly drive into receivers and set parking brake C. Lower receivers by adjusting park stand.
2. Pump motor does not run	A. Defective solenoid B. Defective pump motor C. Weak or defective battery D. Bad electrical connections E. Defective joystick control box F. Blown 10A fuse supplying power to control box	A. Replace solenoid B. Replace brushes or motor C. Charge or replace battery D. Clean and tighten connections E. Replace control box F. Replace fuse
3. Pump runs with joystick in neutral position	A. Defective solenoid B. Defective joystick control box C. Wiring short	A. Replace solenoid B. Replace control box C. Locate and repair
4. Plow will not lower	A. Reversed wiring on valve block B. Defective joystick control box C. Defective lift return valve or coil	A. Correct wiring B. Replace control box C. Replace valve or coil
5. Plow will not raise or raises slowly, motor runs	A. Weak or defective truck battery B. Oil level low C. Hydraulic connection leak D. Lift valve not opening properly	A. Charge or replace battery B. Add oil (do not overfill) C. Tighten or redo connection D. Replace valve
6. Plow does not remain raised with joystick in "neutral" position	A. Leakage through pump check valve B. Leakage through solenoid lowering valve C. Internal leakage in cylinder D. Defective joystick control box.	A. Clean valve, or replace B. Clean valve, or replace C. Repack or replace cylinder D. Replace control Box

<b>PROBLEM</b>	<b>POSSIBLE CAUSE</b>	<b>REMEDY</b>
7. Angling cylinders relieve too easily or too difficultly while plowing	A. Relief pressure set too low or too high	A. Have relief pressure adjusted by Hiniker snowplow dealer
8. Oil leaks from cylinder(s)	A. Loose packing B. Defective cylinder	A. Tighten packing 1/8 turn B. Repack or replace cylinder
9. Battery goes dead with power to the control box on and joystick in neutral position.	A. Short in wiring B. Short in valve coil(s) C. Defective joystick control box	A. Locate and repair B. Replace coil(s) C. Replace control box
10. Battery goes dead with power to the control box off.	A. Short in wiring	A. Locate and repair
11. Plow lights are dim	A. Bad connection(s) B. Lights not properly grounded	A. Repair connection B. Properly ground
12. Plow does not clean-up snow from low areas	A. Joystick controller in neutral	A. Controller should be in the down position (float)
13. In extremely cold temperatures, the oil in the hydraulic system is thickened, causing slow functioning of the plow	A. Cold temperatures	A. As the system warms, the oil will thin out and function normally. B. Select a recommended oil from the chart on Page 10 for plowing in extremely cold temperatures.
14. Pump chatters when raising plow	A. Hydraulic oil low	A. Add hydraulic oil until chattering stops. Do not overfill.
15. Oil running out of cap on hydraulic reservoir	A. Plowing on steeply inclined terrain B. Too much oil	A. Avoid excessive inclines or change direction of plowing B. Remove excess oil
16. Vehicle overheats with the plow on	A. Vehicle coolant level low B. Ice and snow buildup in grill C. Insufficient airflow to engine compartment	A. Add coolant B. Remove ice and snow C. Transport plow at lower speeds
17. Plow lights do not operate with plow attached	A. Light switch on joystick control box in "truck" position B. Defective relay C. Faulty light switch on joystick control box D. Blown 10A fuse on vehicle accessory feed	A. Move switch to "plow" position B. Replace relay C. Replace joystick control box D. Replace 10A fuse
18. Truck headlights do not operate properly with plow removed	A. Light switch on joystick control box in "plow" position B. Defective relay	A. Move switch to "truck" position B. Replace relay

# MAINTENANCE



**WARNING:** Do not service or otherwise handle a plow in the raised position unless it is securely blocked against unexpected falling. Likewise, when servicing the plow with the wings extended, block wings or disassemble wing return springs to prevent unexpected wing retraction due to accidental loss of hydraulic pressure or cylinder removal.

Dependable snowplow operation is the result of following good maintenance procedures. Inspect your plow frequently to ensure that all parts are working smoothly, and develop a schedule for maintenance at required intervals.

## GENERAL

Wash salt and dirt off the plow before storage. Touch-up any chips or scratches in the paint and apply a light coating of grease to extended cylinder rods to prevent corrosion.

## HYDRAULIC SYSTEM

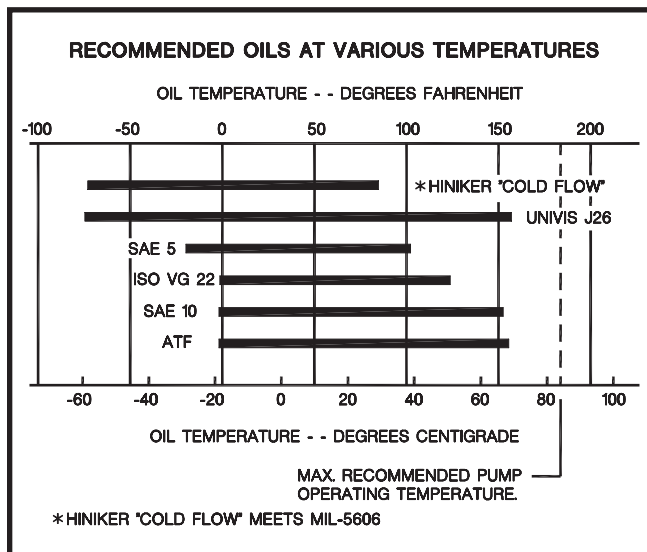

DWG NO. 3066

The majority of snowplow operational problems are caused by bad oil in the hydraulic system. Hydraulic oil should be changed every year for best performance. Select a high quality oil that is appropriate for the temperatures in which you will be plowing snow.

Change hydraulic oil with the wings in the V-position and the plow on the ground. Disconnect three electrical wiring harnesses from the power unit and uncouple three hydraulic lines. Unbolt the power unit from the plow, and remove it to a clean working area that can capture any spilled oil.

Carefully unbolt the oil reservoir from the power unit and discard old oil.

Clean the suction filter at the pump inlet and wipe any metal shavings off the magnet on the pump.

Re-attach the reservoir onto the power unit and re-connect the power unit on the snowplow before adding new hydraulic oil.

Pour hydraulic oil into the power unit reservoir until the oil level reaches the fill line - about 1-1/4 inches from the top.

Raise and lower the plow, and cycle the wings to purge any air trapped in the system. Check the oil level with the plow on the ground and the wings retracted. Add oil to the fill line, if necessary, but do not overfill the reservoir.

## MECHANICAL COMPONENTS

Prior to the operation of a new snowplow, or one which has been stored, inspect all hardware and verify proper torque on all bolts and nuts in accordance with the recommended torque specifications.

### GRADE 5 TYPE B & F LOCK NUT TORQUES

Size	Ft-lbs.	N-m
5/16"	13-18	17-25
3/8"	23-33	31-44
1/2"	58-82	79-112
5/8"	117-165	158-223

### GRADE 5 BOLT TORQUES\*

Size	Ft-lbs.	N-m
1/4"	8-12	11-16
3/8"	29-41	39-56
1/2"	73-103	99-140
5/8"	146-206	198-279

\*applications without lock nuts.

Loose bolts can cause hole elongation and part failure resulting in dangerous operating conditions and equipment breakdown.

Check all hardware periodically during the plowing season and keep tightened to specified torques. Replace worn bolts and lock nuts with grade 5 bolts and equivalent type B or type F lock nuts. Type B lock nuts are plain hex; type F lock nuts are flanged hex.

Inspect wear of the cutting edges and the center cone before every plowing season and frequently throughout the season. Replace cutting edges and the center cone before wear is into wing or mast sections to avoid damage to these components.

The three 5/8 inch flat socket head screws that fasten the center cone to the bottom of the plow are factory retained with anaerobic threadlocker. If removal or replacement of these screws is necessary, purchase new screws with threadlocker from your Hiniker dealer or apply a commercially available threadlock, i.e., Loctite 242 (blue) to the threads before reassembly. Torque all three screws to 125 Ft. lbs (170 N-m).

Once a year before using the plow, check that the plow will trip freely about its trip pin. With the plow mounted on the truck and lowered to the ground, loosen the four trip springs and pull the top of the moldboard forward. If the moldboard doesn't pivot freely, remove the trip pin and apply a commercially available anti-seize lubricant. Damage to the plow or truck may result if the moldboard hits an obstruction during use and doesn't trip.

Retighten the trip springs by turning the nuts on the spring studs until the coils begin to separate. Secure spring studs by tightening top and bottom nuts together to produce a rigid clamp.

At least once a year, grease the center hinge pin on the moldboard by injecting a high quality, general purpose grease into each bushing pin hole with a grease syringe.

Grease the adjustable stop bolt behind the center mast at least once a year with a high quality, general purpose grease to prevent corrosion.

The 5/16" hex bolts in the latch sliders are factory retained with anaerobic threadlock. If removal or replacement of these bolts is necessary, purchase new bolts with threadlocker from your Hiniker dealer, or apply a commercially available threadlock, i.e., Loctite 242 (blue) to standard 5/16-18 X 3/4" grade 5 hex bolts before reassembly.

## ELECTRICAL MAINTENANCE

Periodically check all electrical connections for proper fit and remove any contamination that may be present.

To prevent contamination always place dust caps on connectors when not in use. This is particularly important when the plow is being stored. The use of dielectric grease is recommended to reduce corrosion of the contacts and to make connecting and disconnecting easier.

Before each season check vehicle battery and electrical system for proper operation. A weak battery, dirty terminals, or faulty charging system may cause improper operation and possible failure of the joystick controller.

# PLOW ASSEMBLY

## GENERAL INFORMATION



**WARNING:** To prevent personal injury or death, be certain to keep clear of any parts that may drop when removing bundling straps, wires or brackets. Support heavy sections with hoist or blocks before removing wires or straps.

In the following instructions, left and right machine references are defined as being viewed from the cab of the truck.

Be certain that hydraulic hoses and electrical wires are safely routed and allow full motion of moving parts. Secure loose wires with plastic tie straps.

Some components are fastened at incorrect locations for shipping purposes.

All hardware should be tightened only enough to ensure safety during assembly. Torque hardware to specified values, as shown in the following chart, only after assembly has been completed.

### GRADE 5 TYPE B & F LOCK NUT TORQUES

Size	Ft.-lbs.	N-m
5/16"	13-18	17-25
3/8"	23-33	31-44
1/2"	58-82	79-112
5/8"	117-165	158-223

### GRADE 5 BOLT TORQUES\*

Size	Ft.-lbs.	N-m
1/4"	8-12	11-16
3/8"	29-41	39-56
1/2"	73-103	99-140
5/8"	146-206	198-279

\* applications without lock nuts

Replace worn bolts and lock nuts with grade 5 bolts and equivalent type B and type F lock nuts. Type B lock nuts are plain hex; type F lock nuts are flanged hex.

## PLOW ASSEMBLY

1. Lift the snowplow moldboard assembly to a clear level working area by hooking hoist chains through the two holes in the top plate of the center mast. The hoist should be capable of lifting at least 1,000 lb. loads.

Remove two side markers and 5/16 inch hardware from the top of the moldboard, and set aside for assembly later. Save two sets of 5/16 inch hex bolts, flat washers and lock nuts from the shipping brackets for assembling the side markers.

2. Open the frame crate and set aside the power unit box, headlamp boxes and parts boxes for later assembly. Remove the frame assembly from the shipping crate to a piece of cardboard or other padding that will prevent scratches in the paint.

Locate the 3/4 inch X 4-1/4 inch hex bolt, 3/4 inch nylon insert lock nut and one 90° O-ring/flange hydraulic fitting in the hardware bag in the parts box.

Install the O-ring end of the 90° fitting into the lift cylinder port so that the flared end points toward the rod end when tightened. Swing the lift frame up to its approximate working position and hold with a hoist or forklift.

Bolt the upper lift links to the outside of the two lugs on the lift frame, then pin the lower end of the lift cylinder between the two lugs on the frame assembly with the hardware provided.

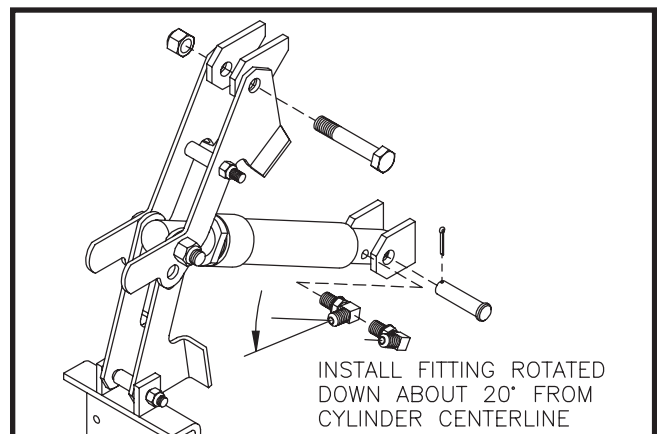

Pin the parking stand to hold the square tubes of the push frame parallel to the ground.

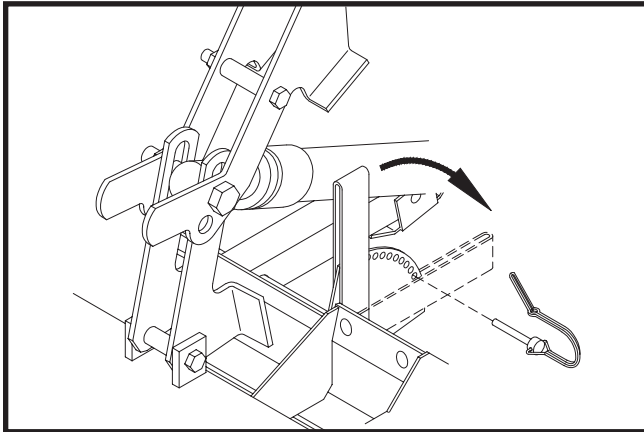

DWG NO. 4168

clevis pin from the hardware bag so that the bar is in the position shown in the following illustration.

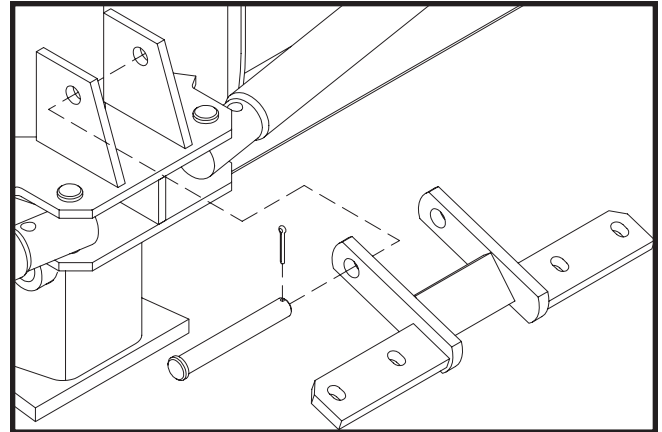

DWG NO. 4171

The bottom surface inside the two prong receiver channels should measure about 10 inches above the ground in the working position.

- Remove the trip pin from the front of the frame assembly by removing one cotter pin and the slotted spring pin from the chamfered end of the trip pin.

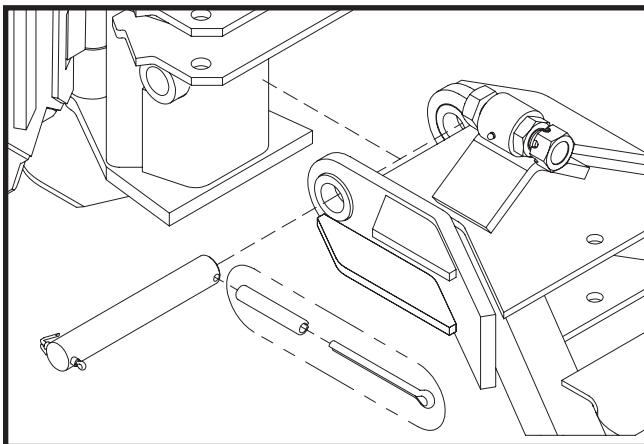

DWG NO. 4170

Fully thread a 5/8 inch hex nut onto each of the four spring studs found in the hardware bag, then put a stud onto one end of each of the four trip springs.

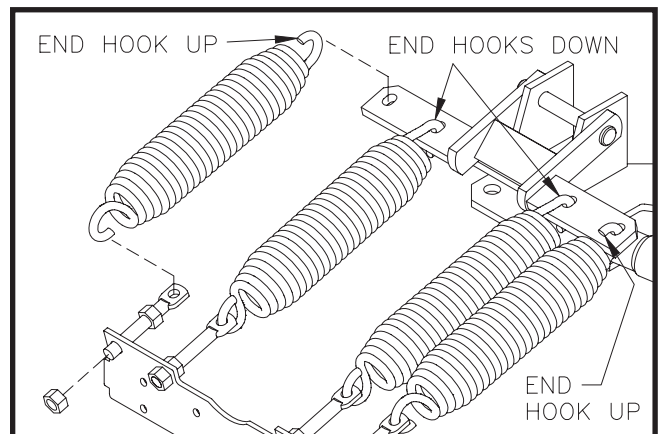

DWG NO. 4196

Move the frame assembly to the moldboard assembly and align the two lugs on the pushframe with the bushing at the back of the moldboard center mast. Apply a commercially available anti-seize lubricant (not supplied) to the trip pin to prevent future corrosion, then pin the two assemblies together and secure with the slotted spring pin and cotter pin.

- Pin the trip spring mount bar from the parts box to the outside of the two plates on the back of the center mast with the 3/4 inch X 5-1/2 inch

Assemble the trip springs between the spring mount bar and the cross brace on the pushframe. Orient spring hooks as shown in the drawing.

Thread a 5/8 inch hex nut onto the bottom of each spring stud and tighten the nut until the spring coils begin to separate. Turn the top nut down on each stud until it contacts the cross brace, then fully tighten both nuts to produce a secure clamp.

- Before assembling the power unit on the lift frame, scrape a small amount of paint from the two mount holes in the lift frame to provide a good electrical ground for the turn signals and parking lights.

Mount the power unit on the lift frame with two 3/8 inch X 3/4 inch hex bolts and two 3/8 inch lock washers. The plastic reservoir of the power unit should be to the left side of the plow (see following illustration).

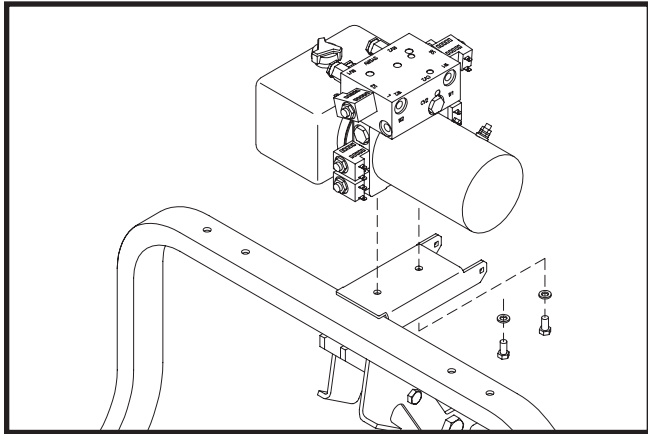

DWG NO. 4190A

Locate five O-ring/flare hydraulic adapters in the hardware bag: four straight adapters and one 90° adapter. Turn the O-ring ends of two straight adapters into ports marked "W1" and "W2" on the power unit. Turn the O-ring end of the remaining two straight adapters into ports in the wing cylinders.

Turn the O-ring end of the 90° adapter into the port marked "L" on the power unit, with the flared end directed toward the fitting on the lift cylinder.

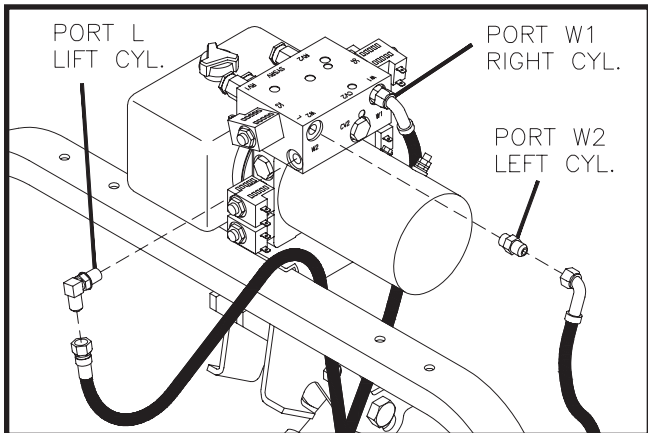

DWG NO. 4191A

Assemble the short hydraulic hose from the parts box between the lift cylinder and the power unit port marked "L". Route the hose ahead of the lift frame tube.

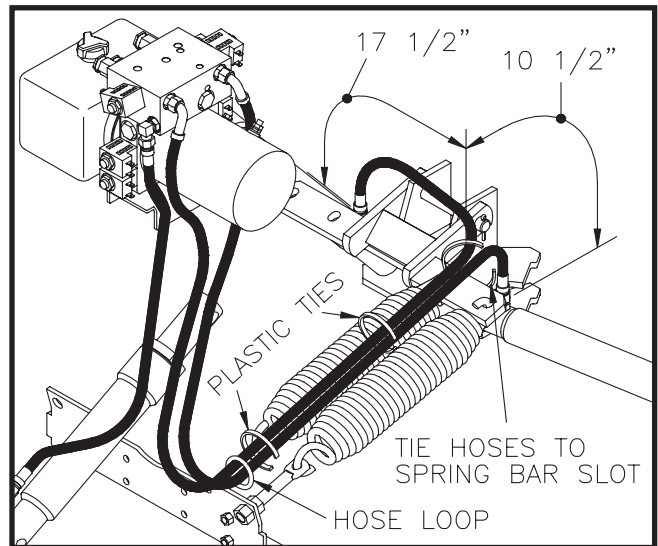

DWG NO. 4197A

Route the two longer hydraulic hoses through the loop on the push frame and over the two RH trip springs such that the straight hose ends will assemble to the wing cylinders on the plow blade and the 90° ends will assemble to the power unit.

Connect the RH wing cylinder to port "W1" on the power unit.

Connect the LH wing cylinder to port "W2" on the power unit.

Band the two wing hoses to the inner slot in the spring bar at the approximate dimensions shown in the drawing. Also band the hoses together just ahead of the hose loop and again about half way between the previous two straps. Pull slack hose behind the hose loop.

6. Before assembling the headlamp brackets on the lift frame tube, scrape a small amount of paint from the three holes in each bracket and the four holes in the frame tube to provide a good electrical ground for the turn signals and parking lights.

Mount the headlamp brackets to the lift frame tube with four 3/8 inch X 2 inch carriage bolts and flanged lock nuts from the hardware bag in the parts box.

Remove the LH and RH headlamps from their boxes and mount on the brackets with hardware from the headlamp boxes.

Use plastic tie straps to band headlamp cables above and below the brackets at the locations shown to provide clearance for the power unit cover rods later.



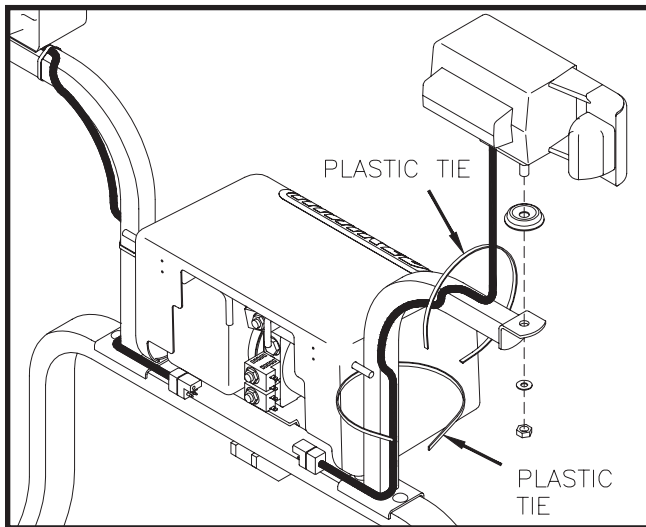

DWG NO. 4172A

- Identify the power cable assembly and wiring harness for the plow power unit in the electrical components parts box. A ground harness for solenoids on the power unit is in the power unit box.

The power cable assembly has two cables with ring terminals on one end and a two pin connector on the other, and measures about 33 inches long.

The wiring harness has a ten pin connector and a three pin connector on one end and the other end has connectors labeled "DRIVER SIDE" and "PSNGR SIDE" for the headlamps, and six loose wires with spade receptacles and one wire with a ring terminal.

The ground wire harness has a ring terminal and six spade receptacles on two wires.

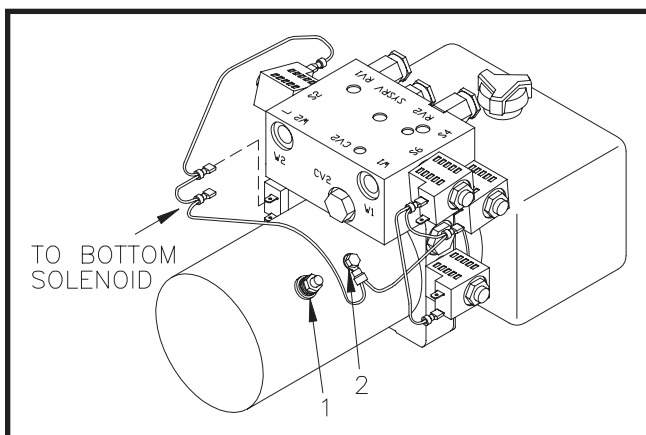

DWG NO. 5434

Attach the ring terminal of the solid red (or red striped) wire of the power cable assembly to the terminal on the power unit at location 1.

Fasten the ring terminal of the solid black wire of the power cable assembly, the black wire with the ring terminal on the plow harness, and the ring terminal of the ground wire harness under the screw on the motor at location 2.

Refer to drawing 5434 and attach the coil ground wire harness as shown.

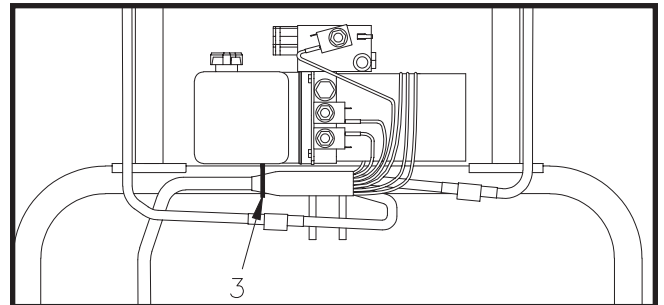

DWG NO. 4210A

Band the plow wiring harness to the power unit with a plastic tie strap, as indicated in drawing 4210A at location 3. Refer to the drawings for routing wires to the power unit and headlamps.

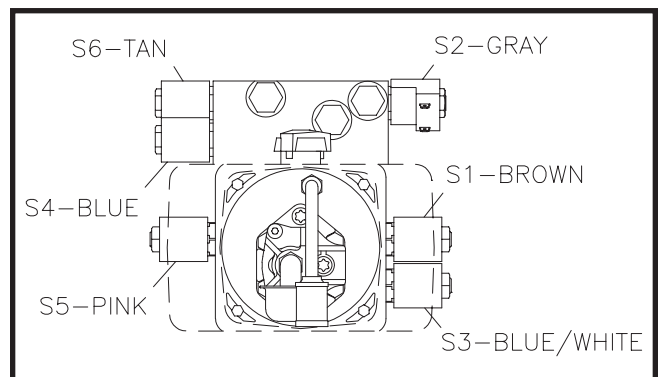

DWG NO. 4174A

Connect the Brown wire of the wiring harness to the spade terminal on solenoid S1.

Connect the Gray wire to solenoid S2.

Connect the Blue with White Stripe wire to solenoid S3.

Connect the Blue wire to solenoid S4.

Connect the Pink wire to solenoid S5.

Connect the Tan wire to solenoid S6.

Connect the RH headlamp to the harness end labeled "PSNGR SIDE" and the LH headlamp to the end labeled "DRIVER SIDE".

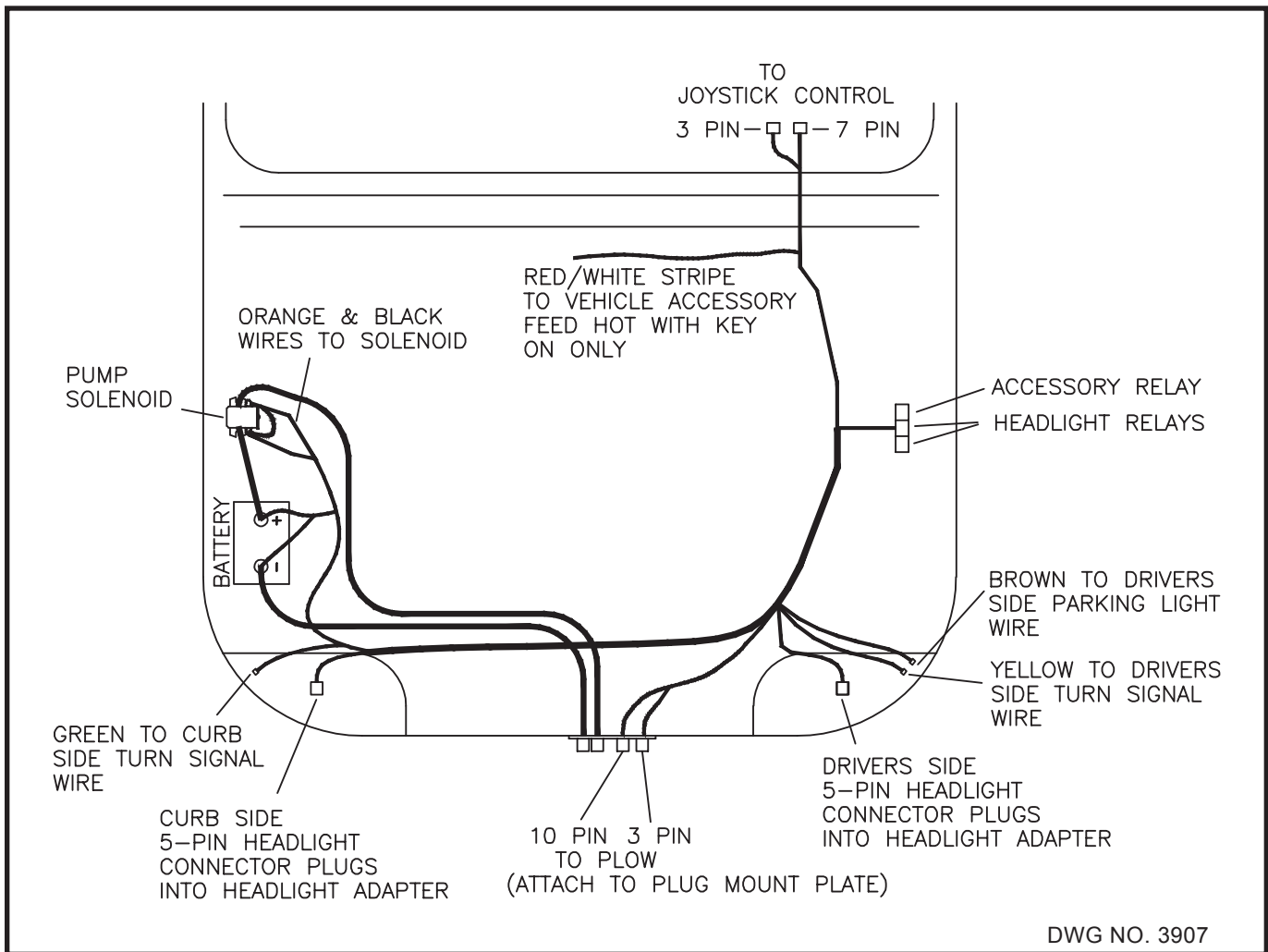

**WARNING: Disconnect truck battery before beginning electrical installation to avoid shock hazard.**

The pump solenoid, underhood wiring harness, power cable and joystick control box are located in the parts box shipped with the snowplow frame.

NOTE: Fill electrical connectors with dielectric grease, and lightly coat ring and spade terminals before installation to prevent corrosion.

8. Refer to drawing 3907. To begin underhood wiring installation, lay the harness in its approximate position for final assembly. Position the 7-pin and 3-pin circular connectors near the drivers side firewall, the 10-pin and 3-pin connectors just left of center near the grill, the relays near the drivers side inner fender and the 5-pin headlight connectors at the respective headlights.

9. Determine the location of the vehicle battery. If the battery is located on the right (passenger) side or if there are two batteries configured as a 12 volt system then proceed to step 10. If the battery is located on the left side of the vehicle then the wiring harness will need to be modified.

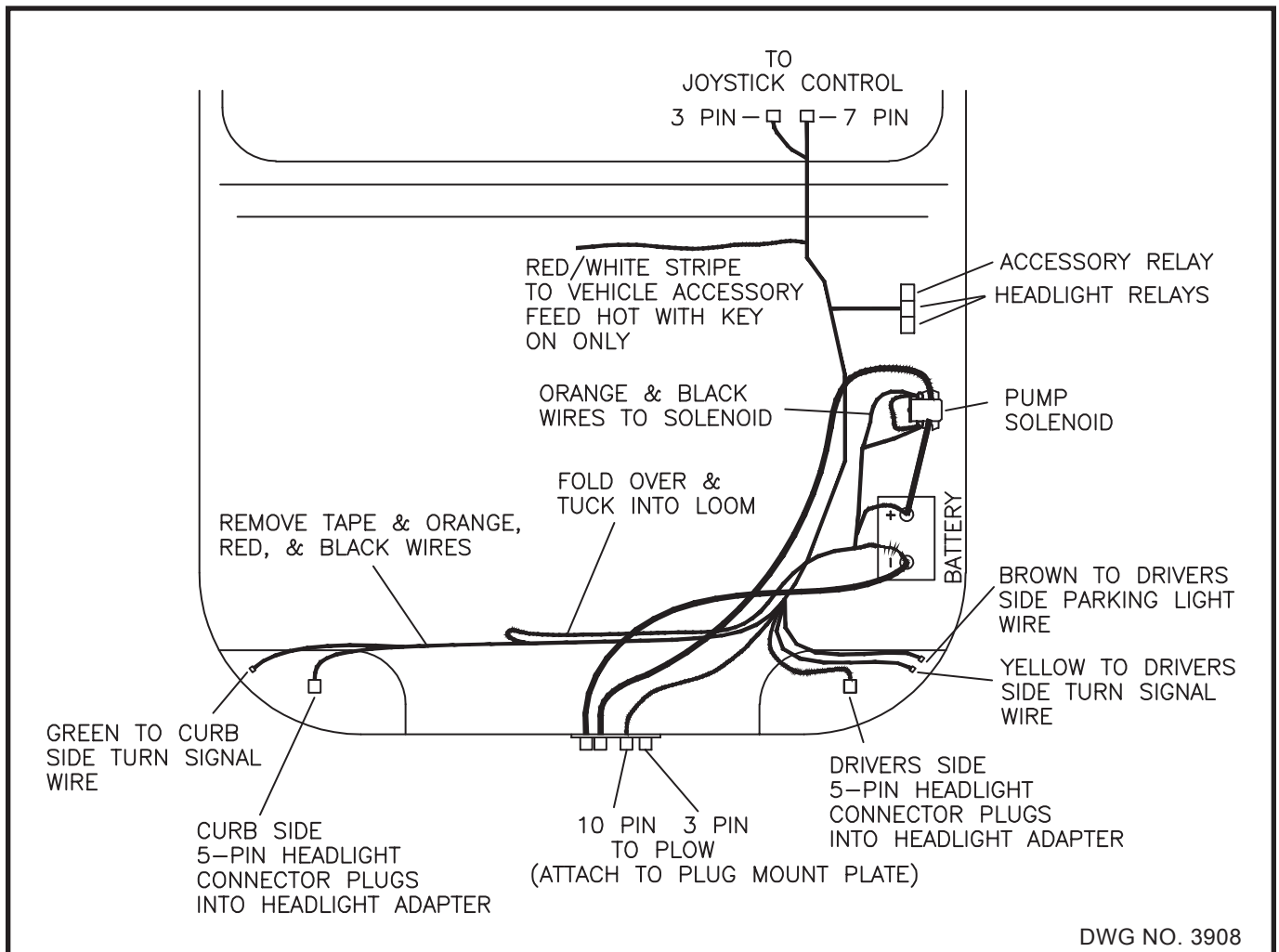

Refer to drawing 3908. Remove the tape from the Black corrugated loom at the points shown. Locate an Orange, Red, and two Black wires. These wires connect to the battery and pump solenoid. Remove the four wires from approximately 33 inches of the loom, making sure the Red and Black wires are long enough to connect to the battery. Tuck these wires back into the loom as shown in the drawing and retape the loom.

10. If there is no access hole in the drivers side firewall then drill a 1-1/8 inch diameter hole. Route the 7-pin and 3-pin circular connectors through the firewall into the cab compartment and install the 4 inch grommet in the hole, if required.



**CAUTION: Ensure that the relays will clear any hood lift/spring mechanisms before installation.**

11. Select an area near the drivers side fender for the relays. Drill three 1/8 inch diameter holes and secure the relays with #8 X 1/2 inch self-tapping screws from the hardware bag in the parts box.
12. Splice the red with white stripe wire to the vehicle's switched 12 volt auxiliary electrical circuit. This will prevent operation of the plow without the vehicle key being on. This wire controls the accessory relay that powers the control joystick and solenoids.
13. Connect the joystick control box to the 7-pin and 3-pin connectors inside the truck cab. Secure the box at a safe location in the cab with the strip of hook and loop fastener.

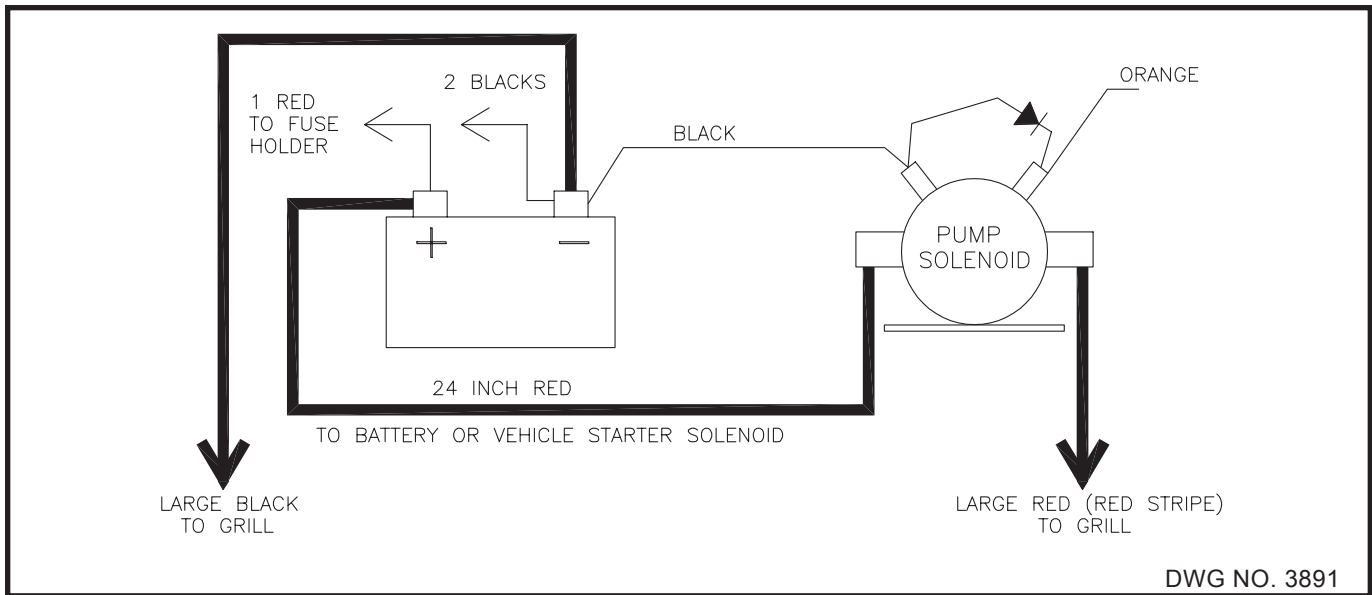

**WARNING:** Ensure that the pump solenoid and associated wiring will clear any hood lift/spring mechanisms before installation.

14. Select an area within 16 inches of the vehicle battery for the pump solenoid. Drill two 3/16 inch diameter holes and fasten the solenoid with two 1/4 inch X 1/2 inch long self tapping screws from the hardware bag in the parts box. Connect the Black wire to one of the small posts on the solenoid, connect the Orange wire to the remaining small post, polarity is not important.
15. Safely route the 10-pin and 3-pin circular connectors through the grill of the vehicle to a location that will be easily accessible with the plow attached.
16. Refer to drawing 3891. Install the underhood power cable by first connecting the ring terminal from the solid Black cable and the two Black wires from the harness to the minus (-) post of the vehicle's battery. Connect the ring terminal from the solid Red (or Red striped) cable to the pump solenoid terminal, route the power cable to the grill near the 10-pin connector.

Install the 24 inch Red power cable between the pump solenoid and the vehicle's starter solenoid positive terminal. If the vehicle's starter solenoid is not accessible, connect the Red (or Red striped) cable to the

plus (+) terminal of the battery. Connect the Red fused wire to the positive terminal of the battery.

17. Remove the plug mount plate kit from the hardware bag in the parts box.

Refer to drawing 5295.

Fasten the power cable connector to the clamp by inserting the #6 X 1 inch machine screw through the small hole in the connector, then through the center hole of the clamp. Secure the screw with a #6 lock nut.

Fasten the clamp to the mount plate with the two #10 X 1-1/2 inch machine screws and #10 lock nuts supplied.

Mount the 10-pin circular connector to the mount plate with four #6 X 1/2 inch screws and lock nuts such that the tab on the connector will be up, as shown.

Mount the 3-pin circular connector to the mount plate with four #6 X 1/2 inch screws and lock nuts such that the tab on the connector will be up, as shown.

Assemble the mount plate and connector covers to the vehicle grill with plastic ties.

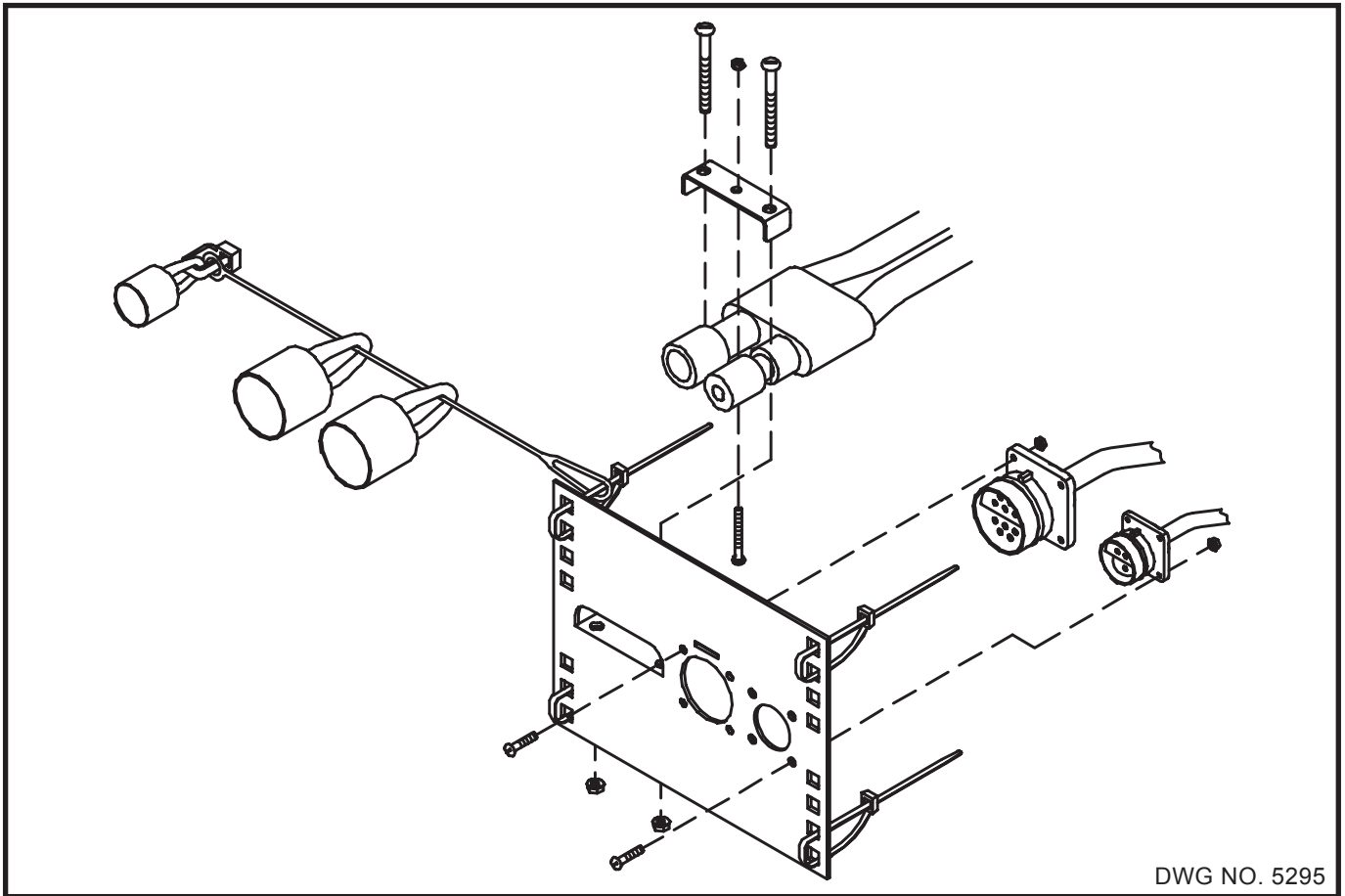

DWG NO. 5295

18. Locate three blue connector splices in the hardware bag in the plow's parts box.

Using a blue splice, crimp the single green wire from the underhood harness into the vehicle's curbside turn signal wire.

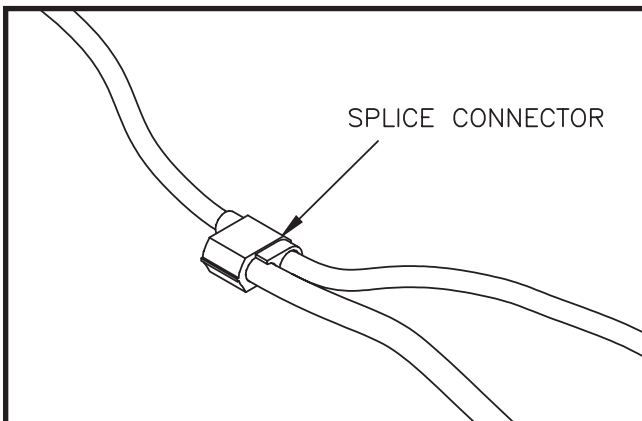

DWG NO. 4165

19. Select the proper headlight adapter for your vehicle, specific instructions are included with each kit.

The headlight adapter kit consists of two identical adapters. Install the adapters according to the instructions included with the kit and connect to the 5-pin connectors of the underhood wiring harness.

20. Secure all cables away from hot or moving components with cable ties.

Using a blue splice, crimp the single brown wire from the underhood harness into the vehicle's driver's side parking light wire.

Using a blue splice, crimp the single yellow wire from the underhood harness into the vehicle's driver's side turn signal wire.

This completes the Electrical Installation.

20. At this point, assemble the mount kit on the truck as described in the instructions supplied with each kit.

Prongs from the truck mount kit should be at a height that will slightly lift the plow frame when attaching the plow.

Apply powdered graphite on the prongs to help the plow slide on and off more easily.

Prong receivers on the plow frame must be parallel to the ground before attaching the plow.

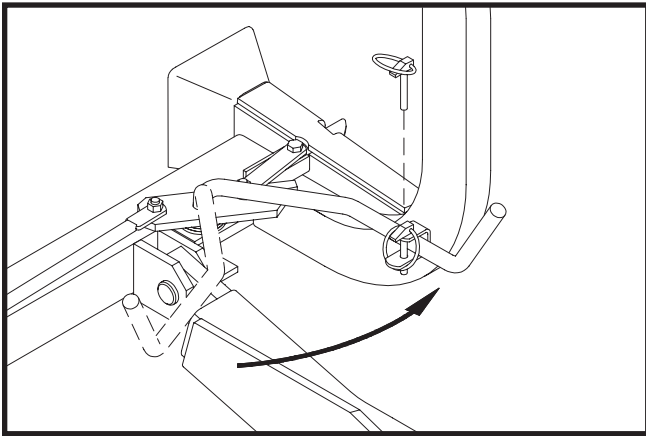

DWG NO. 4166

Attach the plow onto the truck by driving the truck prongs into the receivers on the plow frame. Pull the latch handle into the frame clevis to move sliders through the notches in the prongs and receivers. Pin the handle in the clevis with its klik pin.

Raise the parking stand to its highest position and repin.

Connect the three electrical cables from the plow to their corresponding receptacles on the truck.

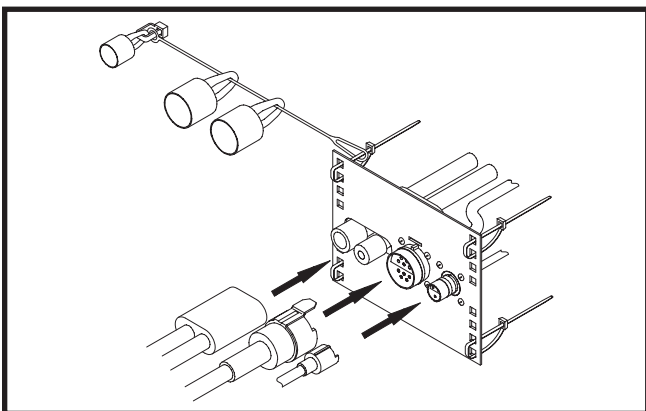

DWG NO. 5232

21. Select an appropriate hydraulic oil from the accompanying chart.

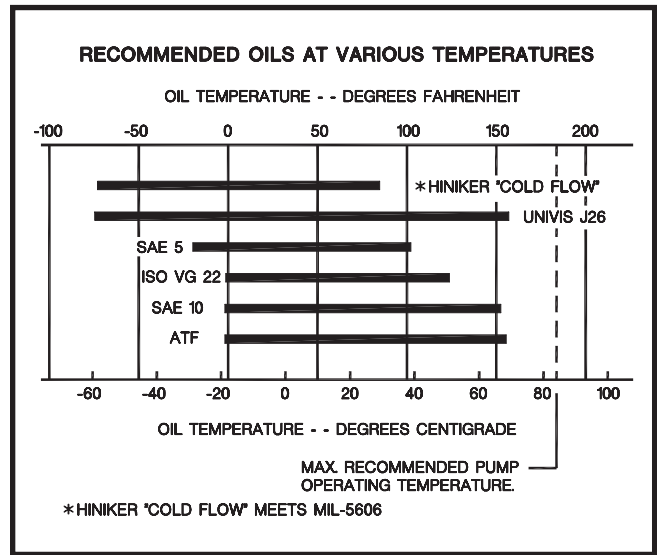

DWG NO. 3066

Pour hydraulic oil into the power unit reservoir until the oil level reaches the fill line - about 1-1/4 inches from the top.

Remove the two angle irons bracing the wing cylinders while the plow is still on the ground.

Raise and lower the plow, and cycle the wings to purge any air trapped in the system. Check the oil level with the plow on the ground and the wings retracted.

Add oil to the fill line, if necessary, but do not overfill the reservoir.

NOTE: New hydraulic cylinders will leak a small amount of oil until packings become saturated and produce a good seal. If leakage is excessive, or if leaking continues after initial cycling, tighten the cylinder packing nut in 1/8-turn increments until leaking stops.

22. Check that the plow blade is level on the ground with the wings in the scoop position and the plow on the ground.

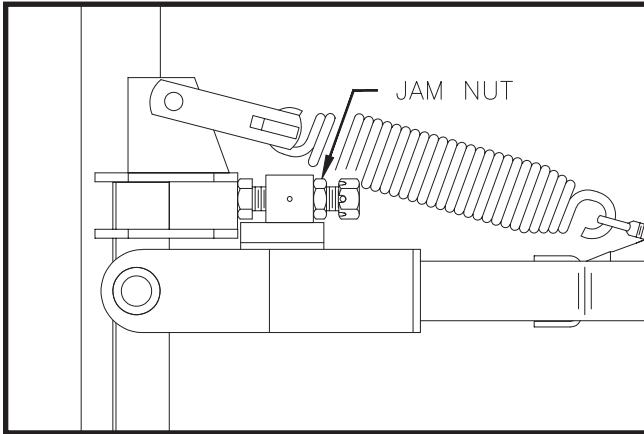

DWG NO. 3847

Level the plow by first loosening the jam nut on the stop bolt at the back of the center mast, then turning the bolt in or out to adjust the plow ends. Retighten the jam nut once the plow is level with the ground. Grease the fitting to prevent future corrosion.

23. Fasten the power unit cover assembly onto the lift frame bracket with two 1/4 inch X 3/4 inch carriage bolts, flat washers and lock nuts from the hardware bag in the parts box. Tighten the lock nuts so that the assembly is secure, yet the cover hinges freely.

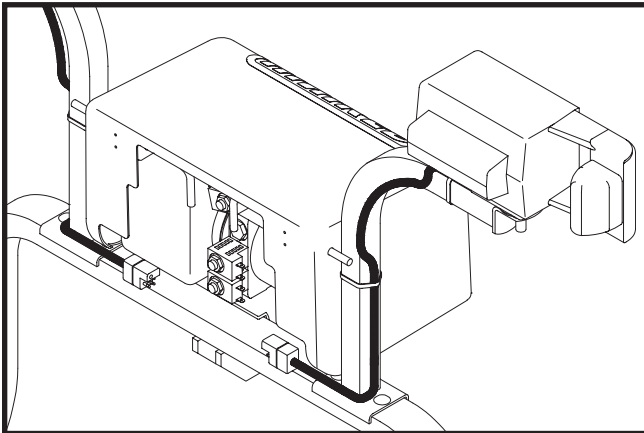

DWG NO. 4198A

Snip the plastic tie strap inside the cover assembly to release the two cover latch handles. When the cover is closed, rods from the latch handles should extend behind the light brackets to hold the cover in place.

24. Assemble side markers on the ends of the moldboard with 5/16 inch bolts, flat washers and lock nuts.

### SYSTEM CHECK-OUT

NOTE: The power cable and wiring harnesses must be connected between the snowplow and truck to test the functions of the headlights and power unit. Vehicle ignition must be switched on.

1. Move the headlight switch on the joystick controller to the "TRUCK" position and turn on the vehicle headlights. High and low beams should operate on the truck.
2. Move the switch to the "PLOW" position. Plow lights should operate in both high and low beams. Vehicle headlights should be off.
3. Test the parking lights and turn signals. Lights on the plow and truck should operate at the same time.
4. In an area clear of bystanders, test joystick functions by raising and lowering the plow and angling side to side.

Raise and lower functions may be reversed, as follows.

### JOYSTICK CONFIGURATION

As supplied from the factory, the snowplow controller raises the plow when the joystick is pulled backward and lowers the plow when the joystick is pushed forward.

These functions can be reversed by reassembling the joystick switch and face plate.

To reverse the face plate, pry the plate away from the controller by inserting a small screwdriver along the side of the plate at location 1 in drawing 5723. Flip the plate over, then reinstall by gently squeezing the long sides together and sliding the four tabs into slots in the controller top.

To reverse the joystick switch, remove four screws from the back of the controller and remove the main circuit board assembly from the case halves.

Gently pull on the edges of the small circuit board at the base of the joystick switch to remove the switch from the five pins on the main circuit board.

Rotate the switch 90°, then gently push the switch back onto the five pins.

Insert the main circuit board assembly back into the case top, making sure the joystick is properly seated and the harness strain relief is inside the case.

Reassemble the case with the four screws, checking that wires are not pinched between bosses.

Test the controller on the snowplow or a plow tester to verify that raise and lower functions match arrows on the face plate.

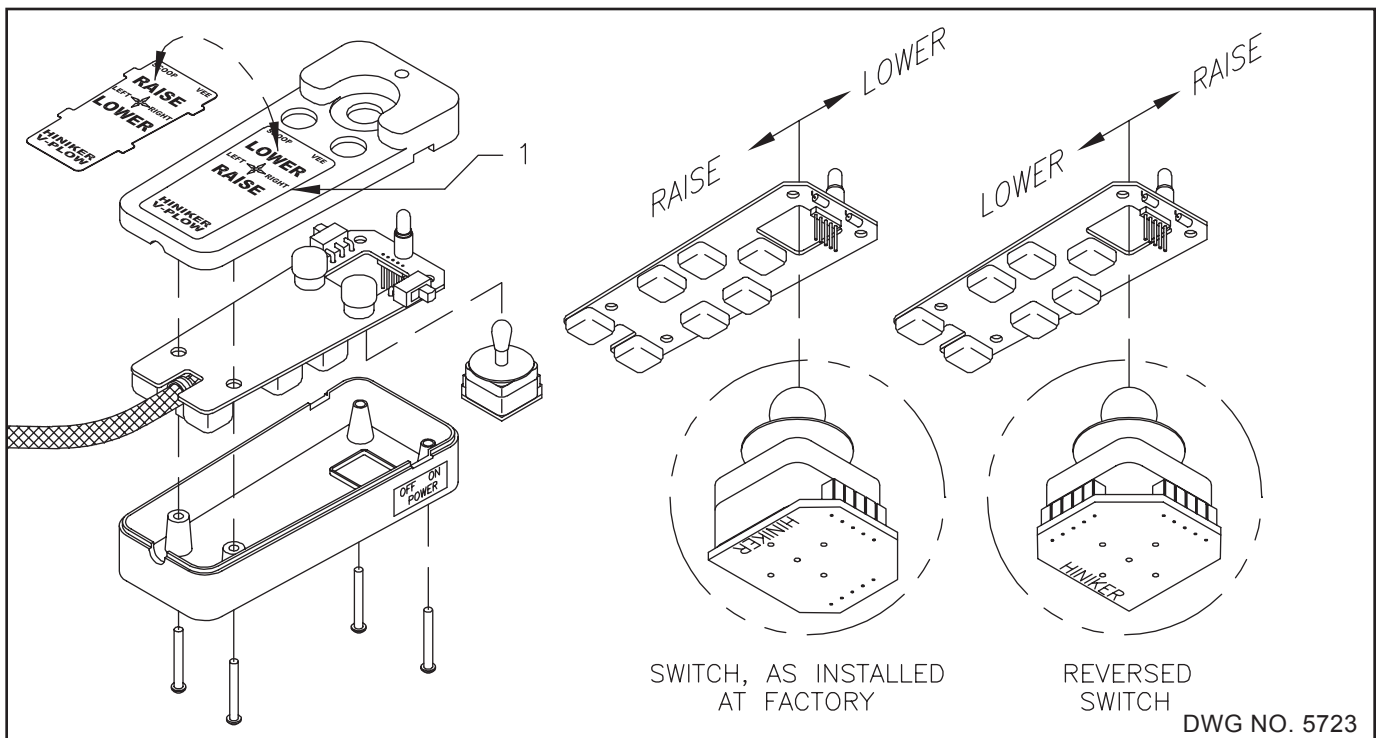



## SPECIFICATIONS

	8 1/2' Plow	9 1/2' Plow
PLOW WIDTH - STRAIGHT	8'6"	9'6"
PLOW WIDTH - "V" POSITION	7'7"	8'6"
PLOW WIDTH - SCOOP POSITION	7'1"	8'0"
PLOW WIDTH - ANGLED 30°	7'4"	8'3"
BLADE HEIGHT	30"	
CUTTING EDGE	1/2" X 6" 1084 Steel	
WEIGHT w/o SNOW DEFLECTOR (Does Not Include Weight Of Mount Kit)	920 lb	980 lb
HYDRAULIC OIL CAPACITY	2 1/2 QTS	
SEALED BEAM HEADLIGHT	HP6545 12 VDC 4.00" X 6.50" (100mm X 165mm) Rectangular Hi/Low (65W/45W)	
TURN SIGNAL/PARKING BULB	One #1157 Heavy Duty Double Contact 32/3 C.P	
WIRING HARNESS FUSE	10 AMP	

# CAB CONTROL

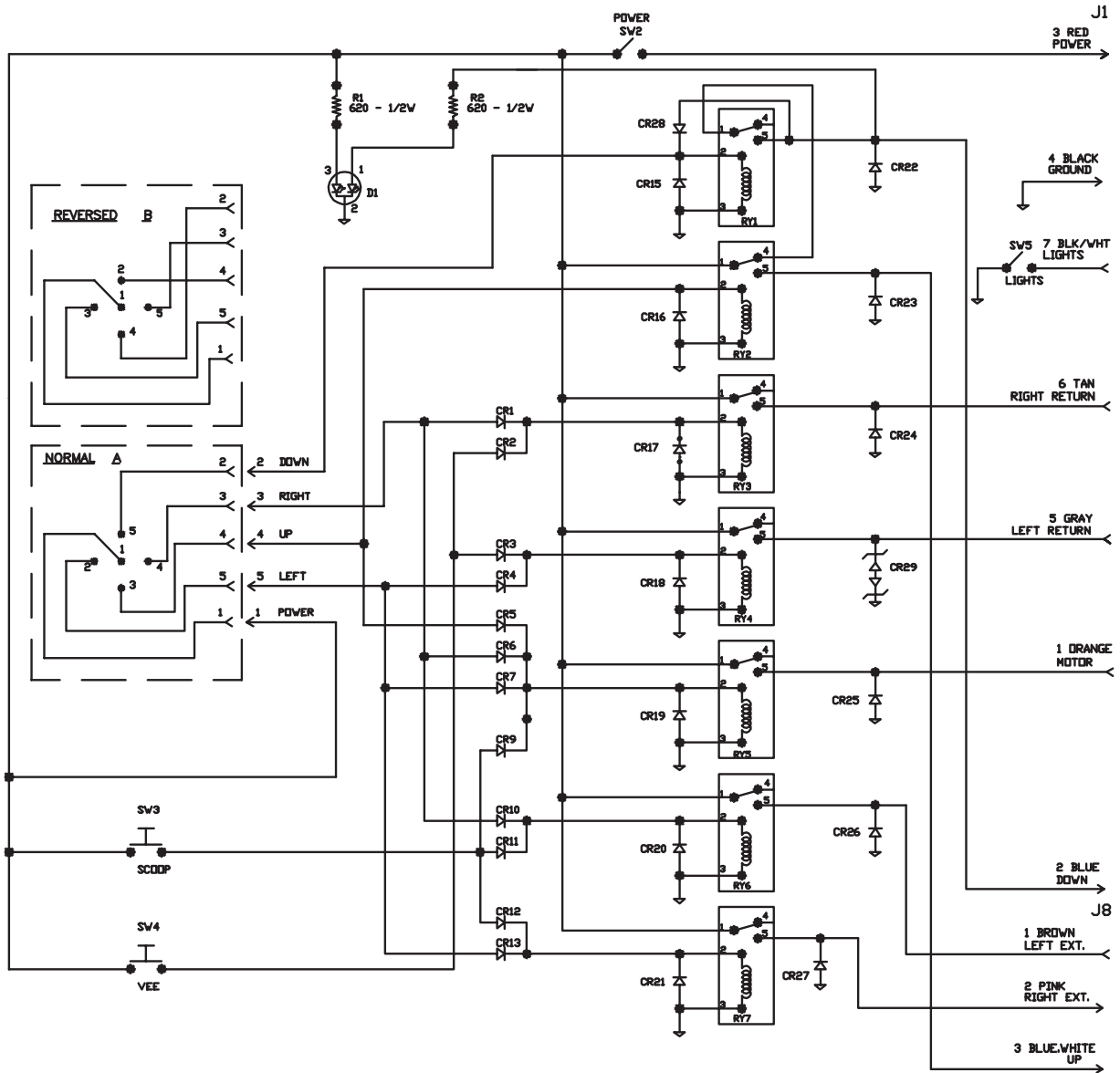

UNDERHOOD HARNESS

EXTERNAL HARNESS

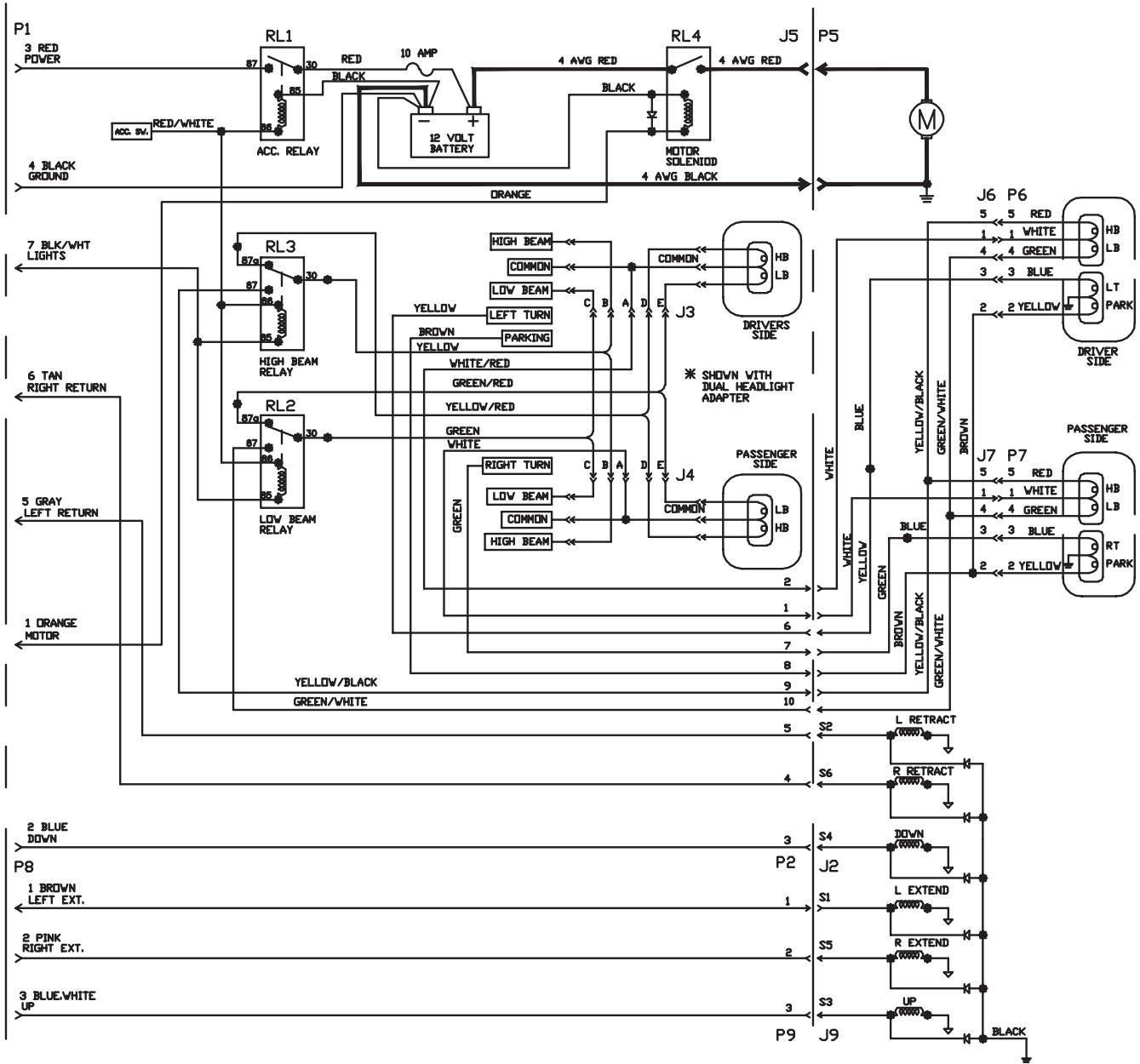

DATE: 3-24-05  
V-PLOW 2005

# V-PLOW POWER UNIT

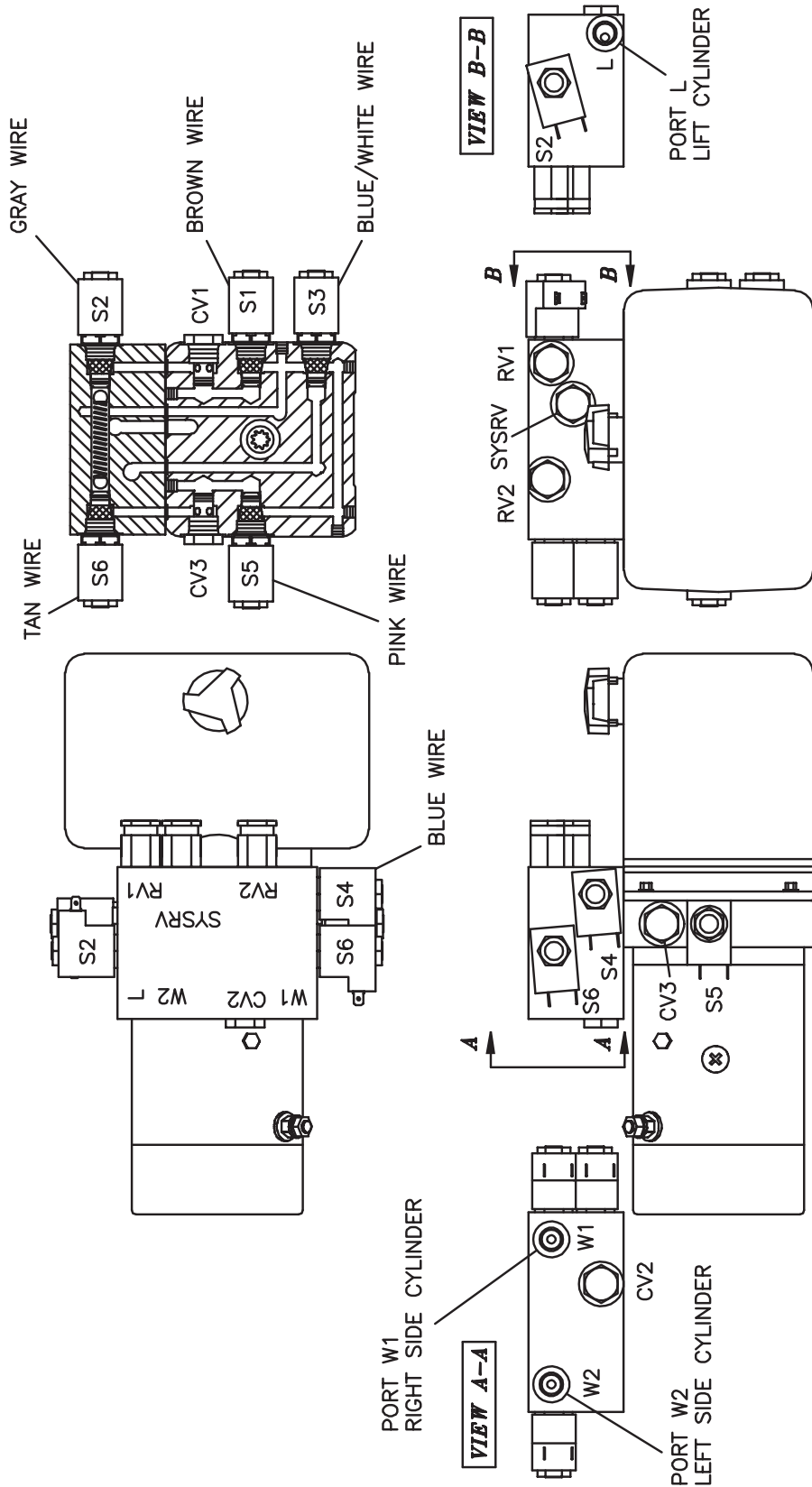

RV1 - RELIEF VALVE, LEFT SIDE WING, 2700 PSI  
 RV2 - RELIEF VALVE, RIGHT SIDE WING, 2700 PSI  
 SYSRV - RELIEF VALVE, SYSTEM, 2250 PSI

# POWER UNIT HYDRAULIC CIRCUIT DIAGRAM

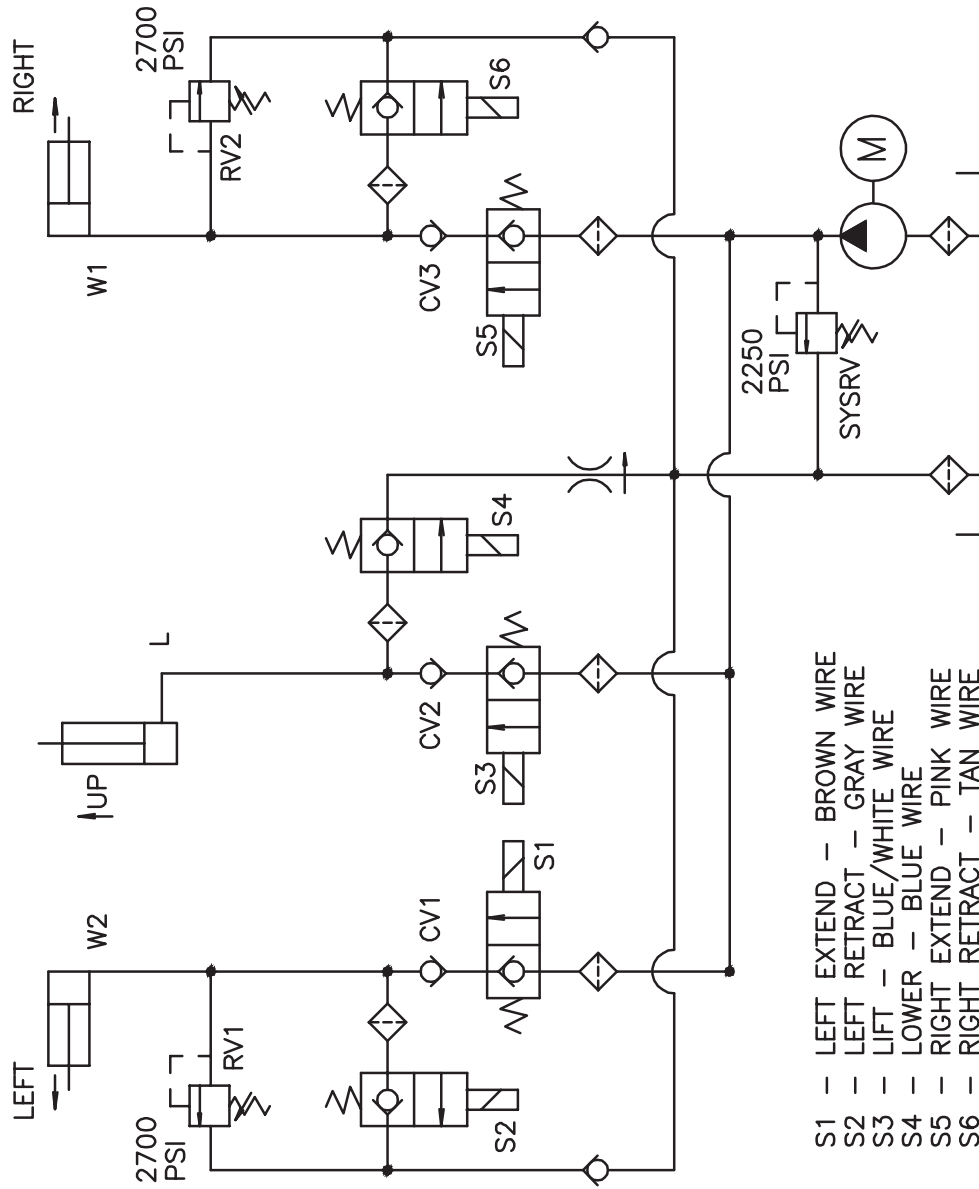

- S1 - LEFT EXTEND - BROWN WIRE
- S2 - LEFT RETRACT - GRAY WIRE
- S3 - LIFT - BLUE/WHITE WIRE
- S4 - LOWER - BLUE WIRE
- S5 - RIGHT EXTEND - PINK WIRE
- S6 - RIGHT RETRACT - TAN WIRE

# HINIKER WARRANTY

## HINIKER SNOWPLOW LIMITED WARRANTY

The only warranty Hiniker Company (Hiniker) gives and the only warranty that any Hiniker dealer is authorized to give on behalf of Hiniker is as follows: **(NO EMPLOYEE OR REPRESENTATIVE IS AUTHORIZED TO CHANGE THIS WARRANTY IN ANY WAY OR GRANT ANY OTHER WARRANTY.)**

Hiniker warrants to the original purchaser of a Hiniker snowplow that Hiniker will repair or replace any defects in material and workmanship that occur within two years from date of retail delivery except the following items: Hiniker warrants that it will repair or replace any defects in materials or workmanship with respect to the paint finish, any accessories, and service parts and components for a period of one year from date of retail delivery.

Hiniker's obligation and liability under this warranty is expressly limited to repairing or replacing, at Hiniker's option, at an authorized Hiniker dealer location, the defective parts at no charge to the original purchaser. **HINIKER MAKES NO OTHER WARRANTY, EXPRESS OR IMPLIED AND MAKES NO WARRANTY OF MERCHANTABILITY OR OF FITNESS FOR ANY PARTICULAR PURPOSE.**

**HINIKER'S OBLIGATION UNDER THIS WARRANTY SHALL NOT INCLUDE ANY TRANSPORTATION CHARGES TO OR FROM THE AUTHORIZED HINIKER DEALER LOCATION OR ANY LIABILITY FOR INCIDENTAL, INDIRECT OR CONSEQUENTIAL DAMAGE OR DAMAGES OF ANY KIND FOR LOST PROFITS OR DELAY.**

If requested by Hiniker, products or parts for which a warranty claim is made are to be returned freight prepaid to our factory. Any improper use, operation beyond rated capacity, substitution of parts not approved by Hiniker Company, or any alteration or repair in such manner as in our judgment affects the product materially and adversely shall void this warranty.

Hiniker reserves the right to make improvements or changes to any of its products without notice. Such improvements or changes shall not trigger any obligation by Hiniker to update, modify or change any products previously sold by Hiniker.

HINIKER does not warrant the following:

1. Used products.
2. Any product that has been repaired, modified or altered in a way not approved by Hiniker Company.
3. Depreciation or damage caused by normal wear, lack of reasonable and proper maintenance, failure to follow Operators Manual Instructions, misuse, lack of proper protection during storage, or accident.
4. Parts replacement and service necessitated by normal wear or maintenance including, but not limited to, cutting edges, hoses, snowplow skid shoes, blade marker guides and hardware.
5. Paint finish damage caused by normal wear.

Hiniker does not assume any liability for any damage to a motor vehicle resulting from the attachment or use of a Hiniker snowplow. Compliance with applicable motor vehicle regulations is the responsibility of the installer. Attachment of a Hiniker snowplow to a motor vehicle is at the risk of the purchaser.

It is the responsibility of the original snowplow purchaser to verify the original date of purchase.

A DELIVERY REPORT FORM must be filled out and received by Hiniker with 30 days of retail delivery at the address below to initiate the warranty coverage.

**HINIKER COMPANY**  
**58766 240th St.**  
**P.O. Box 3407**  
**MANKATO, MN 56002-3407**  
**PHONE (507) 625-6621 -- FAX (507) 625-5883**  
**www.hiniker.com**